

Marwan Kilani

Vocalisation in Group Writing: A New Proposal

Lingua Aegyptia
Studia Monographica

Herausgegeben von
Frank Kammerzell, Gerald Moers und Kai Widmaier

Band 20

Institut für Archäologie
Humboldt Universität
Berlin

Widmaier Verlag
Hamburg

Institut für Ägyptologie
Universität Wien
Wien

Vocalisation in Group Writing

A New Proposal

by

Marwan Kilani

Widmaier Verlag · Hamburg
2019

The open access publication of this work was supported by the Swiss National Science Foundation (grant nr. 10BP12_187039).

Titelaufnahme:
Marwan Kilani,
Vocalisation in Group Writing: A New Proposal
Hamburg: Widmaier Verlag, 2019
(Lingua Aegyptia – Studia Monographica; Bd. 20)
ISSN 0946-8641
ISBN (paperback): 978-3-943955-20-0
ISBN (PDF): 978-3-943955-90-3
DOI: <https://doi.org/10.37011/studmon.20>

© Marwan Kilani 2019
This book is published by Widmaier Verlag, Hamburg,
with open access at www.widmaier-verlag.de



This work is licensed under the Creative Commons Attribution 4.0 International License.
To view a copy of this license, visit <http://creativecommons.org/licenses/by/4.0/>

Druck und Verarbeitung: Hubert & Co., Göttingen
Printed in Germany

www.widmaier-verlag.de

Contents

| | |
|--|-----|
| Foreword..... | 1 |
| §1 Introduction..... | 5 |
| §2 Methodological problems in previous models..... | 7 |
| §3 Group writing – A new approach..... | 11 |
| §3.1 Definition of the corpus | 11 |
| §3.2 The nature of the system..... | 14 |
| §3.3 The number of vowels | 16 |
| §4 Group writing – A new model..... | 19 |
| §4.1 Definition of the interpretative model..... | 19 |
| §4.2 The sign “..... | 22 |
| §4.3 $\text{Ⲛ} = rC / r\#$ and $\text{Ⲛ} = nC / n\#$ | 23 |
| §4.4 Ⲛ in final position | 27 |
| §4.5 Special readings for two groups..... | 27 |
| §4.5.1 k^3 and the development of /a/ in proximity of /k/ | 27 |
| §4.5.2 $\text{Ⲛ} = d^v$ | 29 |
| §5 Group writing – Data and analyses..... | 31 |
| §5.1 Period 1 | 31 |
| §5.2 Period 2 | 34 |
| §5.3 Period 3 | 40 |
| §6 Egyptian */*u and */*u: in light of the Semitic evidence..... | 43 |
| §7 Synchronic analysis | 47 |
| §8 Diachronic analysis..... | 51 |
| §9 Statistical analysis..... | 59 |
| §9.1 Theoretical background | 59 |
| §9.2 Results..... | 62 |
| §10 The development of Coptic Ⲛ | 65 |
| §11 The group Ⲛ – additional observations | 67 |
| §12 The group Ⲛ | 71 |
| §12.1 The group Ⲛ – interpretation..... | 71 |
| §12.2 The group Ⲛ – Attestations in the Onomasticon of Amenope..... | 75 |
| §12.3 Words in construct state – Some observations..... | 92 |
| §13 The case of $\gamma m - \epsilon \text{Ⲛ}$ | 95 |
| §14 Conclusions..... | 99 |
| References..... | 101 |
| Appendix A | 105 |
| Abbreviations..... | 105 |

| | |
|--|-----|
| Attestations | 109 |
| Period 1 | 109 |
| Period 2 | 116 |
| Period 3 | 130 |
| Appendix B | 137 |
| Index of Egyptian words mentioned in the text | 141 |
| Index of groups appearing in the corpus, including variants (Appendix A) | 147 |

Foreword

It is easier to understand the interpretative model presented in this book if one knows how the whole system looks like and works since the beginning.

In this foreword, therefore, I provide a brief but exhaustive description of the functioning of group writing according to my new proposal. The reader who is simply interested in knowing how to interpret group writing words can just read this foreword, and ignore the rest of this study.

As for those who want to understand why my system looks like this, what its theoretical bases are, how the evidence supports it, and how it can be used to confirm the current reconstructions of the Egyptian vocalisation, they will find all this information discussed in detail in the following chapters.

I divide this forward into 10 points, each illustrating a specific feature of my system.

1 • In general, words written in group writing are transcribed according to their contemporary vocalisation. This means that the specific phase of the language must be taken into account when extrapolating the vocalisation, and it also means that a same word can be spelled differently in different periods, if some relevant phonological change took place between such periods.

2 • The group writing orthography indicates only **two** vowels, or better two *vocalic classes*, namely a *back vowel class*, transcribed in the present book as *U*, and a *non-back vowel class*, transcribed here as *A*.

3 • The stressed vowels /u/, /u:/, /o/, /o:/ were treated as belonging to the *back vowel class*, and are transcribed as *U*. The stressed vowels /a/, /a:/, /i/, /i:/, /e/, /e:/ were treated as belonging to the *non-back vowel class*, and are transcribed as *A*.

Words like *y'om (“sea” - vocalisation of the 22nd Dynasty) and *h'u:r(v) (“street”, vocalisation of the 19th Dynasty) were thus perceived (and are transcribed here) as yUm and hUr(v). By contrast, words like *y'am (“sea” - vocalisation of the 19th Dynasty) and *h'ey (“husband” - vocalisation of the 22nd Dynasty) were perceived (and are transcribed here) as yAm and hAy.

The unstressed vowels are often difficult to reconstruct, and therefore difficult to analyse. For this reason this book will focus exclusively on stressed vowels. As a preliminary observation, however, it is worth mentioning that the available evidence suggests that in earlier texts the Egyptians did perceive a distinction between *non-back* and *back* vowels also in unstressed syllables. Moreover, it seems that the unstressed vowel /ə/ was perceived as belonging to the *non-back* class. Both these observations, however, would need further study to be confirmed.

4.a • Vowels belonging to the *back* vowel class are always indicated by the presence of a *w*, which is usually written either with the sign ^e = *w* or with a biliteral sign/group whose second consonant is *w*, such as $\frac{\text{w}}{\text{f}}$. When the *back* vowel is associated with the consonant /t/,

the spelling $\overset{\circ}{\text{c}}$ is also possible (see Kilani 2017a, 200–1). When the *back* vowel is associated with a consonant /k/, the group $\overset{\text{L}}{\text{c}}$ could also be used (see below Point 10 and §4.5.1).

4.b • In group writing, vowels belonging to the *non-back* vowel class are indicated by the presence of a ʒ , which is usually written either with the sign $\text{𐤊} = \text{ʒ}$ or with a biliteral sign/group whose second consonant is ʒ , such as $\overset{\text{ʒ}}{\text{c}}$. In addition, the absence of any marker (either ʒ or w) and the use of single consonantal signs can also indicate a consonant associated with a *non-back* vowel. So for instance, the sequences **sa* or **si* would both be interpreted as *sA* and in principle could be written as $\overset{\text{ʒ}}{\text{c}}$, 𐤊 or 𐤋 .

When the *non-back* vowel is associated with the consonant /t/, the group 𐤌 is usually used.

4.c • The marker ʒ is also used in cases characterised by the *absence* of any vowel.¹ In these cases, I transcribe the ʒ as *0* (= zero), rather than as *A*.

5 • In contrast with what usually assumed in previous scholarship, the sign 𐤎 does not indicate any vowel. Rather, it is a sort of diacritic sign used to modify the pronunciation of the consonant or group to which it is associated. In order to highlight this function as diacritic I transliterate it as ʸ . The nature of such modifications seems to depend on the sign or group to which 𐤎 is associated (see below §4.2). For instance, when associated with $\text{𐤍} = \text{h}$ in the form $\overset{\text{ʸ}}{\text{𐤍}} = \text{h}^{\text{ʸ}}$, it indicates a pronunciation $\text{h}_2 >$ Sahidic u (exclusively), in opposition to the standard pronunciation $\text{h}_1 >$ Sahidic z and u . When associated with 𐤏 in the form $\overset{\text{𐤎}}{\text{𐤏}} = \text{t}^{\text{𐤎}}$, instead, it indicates the actual presence of the phoneme /t/, i.e. it indicates that the sign 𐤏 has a full consonantal value and it is not just an unpronounced orthographic element. When associated with the group $\overset{\text{𐤎}}{\text{𐤏}}$ in the form $\overset{\text{𐤎}}{\text{𐤏}} = \text{ʸr0}$, it indicates a pre-consonantal /r/, i.e. it indicates that no vowel follows the /r/, as already noticed by previous scholars. A few other cases, however, are still unclear, and would need further specific investigation (see below).

6 • Groups marked with *c+w* (where *c* = any consonant), namely groups characterised by a consonant + a *back* vowel, can be read both as *cU* and as *Uc*. A group like $\overset{\text{w}}{\text{c}}$ can thus correspond to both *rU* and *Ur*.

Therefore, for instance, the word 𐤏𐤎𐤏𐤍𐤏𐤎𐤏 , “lotus”, can be analysed as *sA.ʸr0.pU.t(A) = sArpUt(A)*, with $\text{𐤎}^{\text{e}} = \text{pU}$, corresponding to the contemporary (post-20th dyn.) pronunciation **svrp 'ot* > Coptic ⲥⲁⲣⲓⲟⲩ .

By contrast, the word 𐤎𐤎𐤏𐤎𐤏𐤎𐤏 , “chariot”, can be analysed as *mA.ʸr0.k0.Ub.t(A) = mArkUbt(A)*, with $\text{𐤎}^{\text{e}} = \text{Ub}$, corresponding to the contemporary (post-20th dyn.) pronunciation **mvrk 'obt(v)* > Coptic ⲙⲣⲟⲟⲩⲧ (with $\text{ⲟⲩ} = /w/ < /b/$).

1 This, in fact, suggests that the *non-back vowel class* indicated by the marker ʒ would perhaps be better understood as an *absence-of-back-vowel class*, which thus corresponds to all *non-back* vowels and to *absence* of any vowel – as in principle, the absence of a vowel is neither a *back* nor a *non-back* vowel. This distinction, however, is conceptual rather than practical, and therefore will not be discussed further in this study. It may be, however, an interesting topic for further research, as it provides a clue about how the Ancient Egyptians perceived their own vocalic system, and their language as a whole.

This is clearly the most innovative aspect of my proposal. The idea that a same syllabic group may encode both a sequence *cU* and *Uc* may at first appear surprising and even counterintuitive, but as I explain in detail here below, similar pronunciation pairs for the same sign(s) are sporadically attested in other writing systems and in Egyptian itself. The Egyptian evidence provides also clues about the possible origins of such phenomenon.

7 • A sequence with a *back* vowel located between two identical consonants is usually transcribed with the reduplication of the same group, which has then to be read as *cU.Uc*. For instance, the word 𓂏𓂏𓂏𓂏 , “oven”, can be analysed as *tA.rU.Ur* = *tArUr*, with 𓂏𓂏 = *rU.Ur* = *rUr*. Such a spelling corresponds to a contemporary pronunciation **tvr* 'u:r(v), deriving from Sem. **tv(n)nu:r(v)*² and developing into Coptic $\tau\pi\pi$ (with regular /u:/ > /i:/ = *i* in proximity of /r/).

8 • As already observed by previous scholars, the groups 𓂏𓂏 and 𓂏 transcribe exclusively word-final or pre-consonantal /n/ and /r/, i.e. /n/ and /r/ not followed by any vowel. In addition, the group 𓂏𓂏 can be combined with a following /r/ to transcribe /l/. However, as I discuss below (§4.3) and in contrast with what assumed by previous scholars, I believe that such groups should not be understood as codas of the previous syllable. Rather, from the point of view of the graphic (not linguistic) syllabification, it looks like the Egyptians perceived them as connected with the following group, clustered with its initial consonant. Therefore, for instance, the above-mentioned word 𓂏𓂏𓂏𓂏 was likely perceived and syllabised by the Egyptians as *sA-rpU-tA*, rather than as *sAr-pU-tA*, as most speakers of European languages would tend to do.

Although apparently trivial, this distinction becomes crucial in light of point 6 above: since groups characterised by a *back* vowel can be read both as *cU* and as *Uc* (where again *c* = any consonant), and since these preconsontal *n* and *r* clustered with the initial consonant of the following group, then it can be inferred that groups characterised by a *back* vowel and preceded by 𓂏𓂏 or 𓂏 could be read as *ncU* / *rcU* or as *Unc* / *Urc*, but not as **nUc* / **rUc*, as one would expect if 𓂏𓂏 and 𓂏 were perceived as codas of the previous syllable.

Therefore, a word like 𓂏𓂏𓂏 , “spear”, can be analysed as *m0 + ʾr.h-U* = *m0.Urh* = *mUrh*, with 𓂏𓂏 = *Urh*, which perfectly corresponds to the contemporary pronunciation **murh*(v), deriving from Sem. **rumh*(v)³ and developing into Coptic ⲙⲉⲣ(ⲉ)ⲗ (with regular /u/ > /e/ = *e*).

9 • The group $\text{𓂏} = d^v$ is exceptional as it appears to be characterised by a *back* vowel, and must thus be read as *dU* or *Ud* (see below §4.5.2). For instance, the word 𓂏𓂏𓂏 , “comb”, can be analysed as *mA.š0.dU.Ud* = *mAšdUd*, with 𓂏𓂏 = *dU.Ud* = *dUd*, corresponding to the contemporary (post-Ramses II) pronunciation **mvšd* 'o:dv > Coptic ⲙⲁⲩⲱⲧⲉ .

2 E.g. Akk. *tinūru*; Arb. *tannūr*; with assimilation /n/ > /r/ due to the following /r/)

3 E.g. Arb. *rumh*; Hbr. *rōmah*; with metathesis *r-m* > *m-r* like in Ugaritic *mrh* < *rmh*.

10 • Egyptian vowels /a/ and /a:/ after /k/ appear to have shifted to /o/ and /o:/, or at least to have been realised and perceived as back vowels, already during the 18th Dynasty, if not before (see below §4.5.1). This means that after a /k/, a *back* vowel must be expected even in periods before the general /a:/ > /o:/ and /a/ > /o/ shifts took places. Note that instances of such early shift had already been occasionally noticed by various scholars. An example that is often mentioned is the word 𓂏 , which is transcribed as *ku* in Cuneiform texts even in periods when we would expect a pronunciation, and a Cuneiform transcription, **ka*.

As I will discuss in this book, the points just described are all derived from observations based on the Egyptian or Coptic evidence, and the resulting system is fully coherent and can be applied throughout the whole of the New Kingdom. At the same time, this system allows to analyse the Egyptian vocalisation through native Egyptian sources for the first time, and the fact that the readings obtained through it are overall in agreement with the reconstructions advanced so far confirms its general validity.

§1 Introduction

The nature and function of the so-called group writing/syllabic orthography has been an important topic of debate for more than a century. Many hypotheses have been suggested and different, often opposite interpretations have been advanced, without any consensus being reached (see Ward 1996 and Peust 1999 for general reviews of previous scholarship; no major addition to the discussion has been made since then).

Early forms of group writing are well attested in both Old and Middle Kingdom, especially in transcriptions of names and toponyms (Albright 1934, 6–11; Hoch 1994, 487–500), but it is with the New Kingdom and the emergence of Late Egyptian that its most common form becomes widespread.

The rationale for the use of group writing is still not completely clear. Foreign words were usually written with this orthography, which, however, could also be used to transcribe Egyptian words, including terms well attested in Middle Egyptian and thus having a proper Middle Egyptian orthography.⁴ It is possible that in these cases group writing was used to transcribe new pronunciations or previously uncommon variants (Albright 1934; Hoch 1994; Ward 1996; Junge 2005, 43–4). At the same time, however, the presence of both loanwords and new Late Egyptian words transcribed with an orthography that is analogous to the classical Middle Egyptian one⁵ suggests that there was no socio-cultural interdiction to write new words with the ordinary orthography. These observations show that the whole picture was clearly more complex than what it may appear at a first glance.

As for its functioning, it has been suggested that this orthography worked like a syllabary –hence the name “syllabic orthography”–, where each group transcribed sequences of both consonants and vowels, rather than just single consonantal phonemes. However, in which form and to what extent vowels were represented has been rather unclear, until now. In particular, the models and interpretations presented so far appear to be all somehow unconvincing, either because they do not manage to explain all the attested forms, or because they require multiple contradictory vocalic values to be assigned to the same groups, thus resulting in systems of transcriptions that are just too wide and therefore too ambiguous to be really meaningful.⁶

This book aims to present a fresh reassessment of the evidence, first by highlighting the methodological problems affecting the most popular approaches suggested in the past and by discussing what can actually be inferred from the sources, and then by introducing a new model to interpret the group writing orthography based on such observations.

It has to be stressed that this book does not have the ambition of solving all the issues affecting our understanding of group writing. Rather, its primary aim is to offer a methodo-

4 E.g. , *trp* = “goose”, attested since the Old Kingdom, but spelled in group writing as  in the New Kingdom (Erman and Grapow 1926–1963, V, 387.6–9).

5 Such as  = *jsbt* = “seat”, “throne”, attested only from the New Kingdom onward and which, in fact, is a loanword from a Semitic language.

6 See Ward (1996, 33–40) for a discussion of this issue based on a review of previous scholarship.

logical framework and a sketch of a new model that can be the starting point for further future research.

§2 Methodological problems in previous models

Usually, the main issues affecting the solutions suggested so far are related with their methodological frames and with the *a priori* assumptions on which they are based.

A first problem affecting all previous interpretations is the assumption that a system recognising and encoding three vowels /a(:)/, /i(:)/, and /u(:)/ underlies the group writing orthography, as it is the case for various Semitic scripts. Such assumption, however, is not based on any concrete evidence from the contemporary Egyptian texts. Although it is true that the original Middle Egyptian vocalic system was probably phonologically based on a three-vowel opposition, there is no real evidence indicating that this system was still preserved, phonologically and/or phonetically, during the New Kingdom. In fact, the evidence that we have seems to indicate that during the New Kingdom the vocalic system of Egyptian was already moving toward the Coptic one (e.g. Loprieno 1995, 38–9). In addition, and more important, the Egyptian perception of their vocalic system could have actually been very different from both its phonological and phonetic realities, and even if the vocalic system of the New Kingdom were indeed still a tri-vocalic system, there is no reason to assume that the Ancient Egyptians themselves perceived and conceptualised it as such. As consequence, there is no reason to assume *a priori* that the Egyptians felt the need to indicate in writing exactly these three vowels. In fact, they could have also developed a system in which more vowels were indicated⁷ or one in which less than three vowels were graphically distinguished.⁸ Such a discrepancy between the perception of the vocalisation and its phonological reality is not only relatively common in many written languages and writing systems around the world,⁹ but it is also attested in Coptic.¹⁰ Therefore, there is no reason to assume, *a priori*, that the Egyptians perceived as distinct vowels only and exactly the three vowels /a/, /i/ and /u/, and therefore there is no reason to assume, *a priori*, that the vocalic values of group writing must reflect this tri-vocalic division.

Another problematic and somehow related assumption affecting previous interpretations of group writing is the idea that ʒ, w and y, either as independent signs 𓆎, 𓆏 and 𓆐 or as second consonant in biliteral groups (in the case of ʒ, w), are all vocalic markers, or more in general that they all have to be interpreted as graphemes representing distinct phonemes or phones. Other possibilities should also be considered. For instance, one or more

7 For instance distinguishing and transcribing additional vowels that, from a phonetic point of view, were mere allophones.

8 For instance merging two of the three phonological vowels into a single graphic representation.

9 A good example is provided by some varieties of Levantine Arabic, where 5 long + 5 short distinctive vowels can be recognised (see e.g. the following minimal pairs: long vowels: *dār* “house”, *dēr* “monastery”, *dār* “manage (imperative)”, *dōr* “floor”, “level”, “turn”, *dūr* “houses”; short vowels: *fhma* “her understanding”, *fhme* “a single instance of understanding” (marginal form), *fhmi* “my understanding”, *fhmo* “his understanding”, *fhmu* “they understood”) but which distinguish only the traditional *a*, *i*, *u* vowels when written in Arabic script, or distinguish a non-standardised and variable number of vowels (depending on the writer) when spelled in Latin script.

10 Where 𓆎 seems to represent two different vocalic phonemes (see below), and 𓆏 and 𓆐 seem to represent both /u:/ and /w/, and /i:/ and /j/ respectively (Loprieno 1995, 40, 46).

of these signs may have been diacritics, and they could have been used for indicating some modification of the phonetic –consonantal or vocalic– value of an associated grapheme, or they could even have represented the *absence* of a feature or phoneme.¹¹ Again, there is no reason to assume *a priori* that these three elements must necessarily be vocalic markers.

Besides these two theoretical problems, two additional methodological issues often flaw past interpretations of group writing. The first is the fact of focusing mainly (Albright 1934) or exclusively (Hoch 1994) on words of Semitic origin. Although it is true that Semitic loanwords do represent by far the majority of words written in this orthography, they also present a series of specific problems that makes them generally unsuitable to identify any meaningful patterns that may underlie the system.

First of all, the vowels and vocalic structures of Semitic words are usually not fixed, and can be changed to express different grammatical forms or derived meanings. In addition, we generally do not know the exact Semitic language(s) or dialect(s) at the origin of the Semitic borrowings in Egyptian. Are these words from southern Canaanite, northern Canaanite/proto-Phoenician, Akkadian, Ugaritic, Amorrite? Or do they come from some other Semitic language or dialect poorly or not attested at all? Egypt had direct contacts with various North-West-Semitic dialects of the Levantine coast and Syria, and Egyptian scribes used Akkadian as *lingua franca*: Semitic borrowings could thus virtually come from any of these languages. Moreover, even if we knew the exact language or dialect from which the Egyptians took these forms, the attestations of these languages (except Akkadian and Ugaritic) and of their vocalisation during the Late Bronze age are so scanty that any meaningful comparison would be extremely difficult. We could obviously work with theoretical reconstructions, but in this case we have to consider that if on the one hand reconstructions can be very precise on the phonological level, on the other they do not tell us anything about the phonetic realisations of phonemes involved, i.e. about the actual pronunciation that the Egyptians would have heard or perceived.

In most cases it is also impossible to determine when the word was borrowed, as such words may have entered Egyptian decades or even centuries before their earliest attestation in the texts. This is a crucial issue, because during that span of time phonetic changes leading to divergent vocalisations may have occurred both in Egyptian and in the donor language.

Many of the solutions advanced so far have paid little or no attention to such synchronic or diachronic considerations. Nevertheless, these are crucial methodological issues, because any approach that does not take them into account can only produce a huge corpus of words that, however, is not internally coherent and from which, therefore, no coherent result can be expected.

Some of these considerations are at the origin of Zeidler's proposal (1991) for a new approach, mentioned also by Peust in his review of previous scholarship on the topic (1999, 221). In particular, Zeidler recognises the problem of using Semitic forms, and decides to focus instead on those words written in group writing which are attested also

11 Such as the *sukun*, i.e. ^{◌̣}, in Arabic, which indicates the *absence* of a vowel.

in Coptic. In other words, he proposes a change of perspective and he suggests to analyse the words written in group writing starting from their Coptic descendants, rather than from their supposed Semitic prototypes (see also Peust 1999, 221). As he says, using Coptic allows analysing the group writing from an “inner-Egyptian” perspective, bypassing all the uncertainty deriving from the borrowing process highlighted above.

I think this is an excellent solution, from a methodological point of view. Zeidler application of this idea, however, presents problems that need to be addressed. First, on the basis of his article, it seems he did not distinguish the Egyptian words on the basis of the periods in which they are attested. This is a serious issue, which essentially flaws the whole study: group writing is attested over a long period of time, during which various phonological developments took place in Egyptian, especially at the vocalic level. To ignore these phonological changes and to compare all the words only with their Coptic descendants is therefore methodologically problematic: on the one hand it is clear that many of the Egyptian forms may reflect vocalisations that are different from those attested in Coptic, while on the other hand, since these Egyptian forms may come from different periods, that is from different “phonological phases”, the way their vocalisation relates with the corresponding Coptic forms may change from one word to the other, if their attestations are not synchronic. For instance, we know that the phonological change /a:/ > /o:/ likely took place just after the reign of Ramses II (Loprieno 1995, 38). It is therefore to be expected that in words from before Ramses II, Coptic /o:/ will be transcribed as a *non-back* vowel, while in those after his reign it will correspond to a *back vowel*. However, if words from both periods are compared together, without chronological distinction, as Zeidler seems to do, then an inconsistency has to be expected, as it will seem that the same vowel could be transcribed in two different ways without apparent reason.

In addition, Zeidler, follows the previous scholars in assuming a vocalic system based on the three vowels /a/, /i/, /u/, without considering that, as said, the Egyptians’ perception and conceptualisation of their vowels could have been different. Similarly, he also assumes that *ʒ*, *w* and *y* act as vocalic markers, without considering any other possible functions.

Another problem in Zeidler’s work is the inclusion of both nouns and verbs in his corpus. The inclusion of nouns is not an issue: their morphological variability is relatively limited and the evolution of their vocalic patterns is relatively well understood. Verbs, however, are problematic from many points of view. First, Egyptian verbal morphology is complex and includes various forms that were likely vocalised in different ways. Therefore, to be meaningful, any comparison between Egyptian verbs and their Coptic descendants should be strictly limited to corresponding morphological forms. This, however, is often impossible, because various verbal forms attested in Late Egyptian did not survive into Coptic. For this reason I think that verbs should be excluded from any preliminary work on group writing: it is clear, in fact, that the uncertainty about both the vocalisation of their Late Egyptian forms and their relation with the Coptic attestations is likely to flaw any model built on them.

Finally, Zeidler did not publish the corpus on which his analysis is based, and he only provided a few selected examples for some of the groups he studied. This is a serious

shortcoming, because it makes it impossible to verify his data, and therefore the validity of his comparisons and results.

It thus appears that various problems affect the models presented so far, either because of the theoretical assumptions they are built on, or because of the composition of the corpora they used, or because of both. Since these issues are essentially methodological, they should be taken into consideration in any new attempt to analyse the group writing.

The interpretation I am presenting in this book does that, as I discuss here below.

§3 Group writing – A new approach

§3.1 Definition of the corpus



As already suggested by Zeidler, working with words attested both in group writing and in Coptic is probably one of the best possible solutions, from a methodological point of view. Such words, therefore, are at the basis of my corpus as well.¹² A few important differences, however, distinguish my dataset from his.

First, only forms for which the vocalisation can be reconstructed with reasonable certainty have been considered. Verbs have therefore been excluded, for the reasons discussed above. As for nouns, only those with a reasonably likely direct descendant in Coptic have been considered. For instance, Egyptian forms which are related with Coptic words, but do not seem to be their direct ancestors, have been excluded.¹³ Similarly, words attested only in differing morphological forms (especially singular versus plural) have also been excluded, except when the corresponding forms can be reconstructed with some certainty. Moreover, and this is the most important difference with Zeidler's approach, the words of my corpus have been distributed into three chronological groups, corresponding to three phonological phases divided by major phonological developments of the vocalisation. Therefore, my model is built on the comparison of the attested Egyptian words with the corresponding contemporary vocalised forms as they can be reconstructed from Coptic, rather than with the Coptic forms themselves.

26 words of my corpus belong to the first period. 49 instead are attested in the second, while 23 in the third. 17 words are attested in more than one period. Of these, 5 are attested in all the three periods.

The first group consists of words attested before or during the reign of Ramses II, and presents a vocalic landscape which is essentially that of Middle Egyptian, except for a possible shift /i/ > /e/ (Loprieno 1995, 38). The second groups, instead, consists of words attested in the period going from the reign of Merenptah to the end of the 20th Dynasty, and it is characterised by the phonological shift /a:/ > /o:/, which likely took place at the end of the previous period, from around 1200 BCE (Loprieno 1995, 38). Finally, Period 3 is characterised by two additional phonological changes, namely the merging of /e/ and /u/ into /e/, and the shift of /a/ into /o/. It is usually assumed that the merging /u~/e/ > /e/ took place at some point around 1000-800 BCE (Loprieno 1995, 39). As for the change /a/ > /o/, it is assumed to have taken place around or after 1000 BCE (Loprieno 1995, 39,

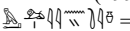
12 I based my corpus on the words identified by Černý (1976), Vycichl (1984) and Westendorf (1965) in their etymological dictionaries, as well as on those suggested by Ward in his review (1996) of Hoch's (1994) and Schneider's (1992) works.

13 Such as, for instance,  = *mrynt* = "a vessel", which Černý suggests may be related with Boharic *μεραν* = "tank". The connection is very doubtful, as pointed out by Hoch (1994, 137, n44), but even if the two words were really related, then the Coptic form would clearly derive from a variant that was different from the form attested in group writing, because the Coptic form does not bear any trace of the *y* and *t* consonants implied by the  and  groups of the group writing spelling.

46). In particular, this shift is already attested in the transcription of some Egyptian words in the Assyrian sources of the time of Sargon II, around 720 BCE,¹⁴ while my study of the *w*-extended orthography (Kilani 2017a – see below) shows it was already in place at the time of the redaction of the tale of Wenamun, and thus possibly as early as the beginning of the 21st Dynasty.

The resulting chronological framework, and the corresponding vocalic landscape for each period, can be summarised as in tables 1–2.

Other important phonological changes affected the Egyptian vowel /u:/. However, both the nature of such changes and their chronological frame are rather unclear. As summarised by Peust (1999, 228–30), Coptic η seems to have transcribed two different phonemes, possibly an unrounded /e:/ and a rounded /ø:/. At the same time, Coptic η appears to also derive from two different phonemes, namely from an earlier /i:/ and an earlier /u:/. The relation between these two Coptic pronunciations and the two earlier vowels is not clear. It has been suggested that the first are the direct reflexes of the latter, but the evidence is far from being convincing and conclusive (Peust 1999, 228–30). In addition, in many cases earlier /i:/ remains /i:/ = ι until Coptic. This, actually, seems to be the regular development, while /i:/ tends to turn into /e:/ = η mainly in specific phonological contexts, like after /n/ = η and /m/ = μ , and before /j/ = ι (Peust 1999, 231–2). However, there are clear attestations of the development /i:/ > /e:/ = η also in other unexpected phonological contexts, which suggests that the picture was either less regular, or more complex (Osing 1976, I, 19-26; Peust 1999, 231–2).

Similarly, /u:/ does seem to shift regularly to Coptic η , except in proximity of /r/ and possibly after etymological pharyngeal, where it turns into /i:/(~/y:/?) = ι (Loprieno 1995, 48; Peust 1999, 231). However, as said above, such Coptic η seems to have had two different pronunciations, whose relation with earlier /u:/ is not clear.

It is therefore clear that these changes cannot be used to define any chronological frame. The evidence emerging from the present study, however, may shed some new light on these issues of historical phonology (see below §10).

14 See for instance the word “Pharaoh”, transcribed in the Annals as **pi-ir-²u-u* or **pi-ir-²u* (Vycichl 1984, 177), corresponding to Egyptian **pə-r-ʕ'oʔ*, from earlier **pir-ʕ'aʔ*.

Table 1 – Short vowels

| Late/Coptic | o = /o/ | Δ = /a/ | Δ = /a/ | Δ = /a/ | e = /e/ | Δ/0/e/i = a/0/e/i | 0 (+ -2× sonor.) |
|-----------------|----------------------|-----------------------------|-----------|-----------------------|--------------|-------------------|-----------------------------------|
| Period 3 | /o/ = U /a/ > /o/ | /a/ = A /a/ + -/ʃ~X/ > a | /e/ > /a/ | /e/ + -/?/*~? /e/ = A | /e/ + sibil. | Δ/0/e/i = a/0/e/i | 0 (+ -2× sonor.) /e/ + -sonor. |
| Period 2 | /a/ = A | /a/ = A | /e/ = A | /e/ = A | /u/ = U | | |
| Period 1 | /a/ = A | /a/ = A | /e/ = A | /e/ = A | /u/ = U | | |
| Middle Egyptian | /a/ = A | /a/ = A | /i/ = A | /i/ = A | /u/ = U | | |

Table 2 – Long vowels

| Late/Coptic | i = /i:/ | H = /e:2/ | i = /y:/ (> /i:2/ ?) | H = /ø:/ (> /e:/ ?) | (e) = /e/ | ω = /o:/ | oy = /u:/ |
|-----------------|----------|-----------|---|---------------------|-----------|----------|---------------------------|
| Period 3 | /i:/ = A | | /i:/ + /ʃ~j/ ~ others? > /e:/ = A; /u:/ (?) > /e:/ ~ /ø:/ ? = A; /u:/ + /t/ ~ X- > /y:/ (> /i:2/ ?) = A | | | /o:/ = U | + -/? ~ /N/ - /o:/ = U |
| Period 2 | /i:/ = A | | | | | /o:/ = U | /o:/ = U |
| Period 1 | /i:/ = A | /i:/ = A | | /u:/ = U | | | a: > o: /a:/ = A |
| Middle Egyptian | /i:/ = A | /i:/ = A | | /u:/ = U | | /a:/ = A | /a:/ = A |

Notes:

* /ʔ/ < /ʔ/ ~ /t/ ~ /r/ ~ /j/ ~ /w/

Period 1: 18th – early 19th (Ramses II); i.e. from 1550 BCE and before 1200 BCE

Period 2: Late 19th (after Ramses II) – 20th; i.e. after 1200 BCE and before 1000 BCE

Period 3: 21st – 22nd; i.e. after 1000 BCE and before 700 BCE

U = back vowel : /o/, /o:/, /u/, /u:/

A = non-back vowel : /a/, /a:/, /e/, /e:/, /i/, /i:/

X = etymological pharyngeals

~ = “or”

–C = “followed by”. E.g. /e/ + –ʔ/ = /e/ followed by /ʔ/.

C– = “preceded by”. E.g. /o:/ + /N/– = /o:/ preceded by /N/.

C without any – = “in proximity of”. E.g. /i:/ + /ʕ/–/j/ = /i:/ in proximity of /ʕ/–/j/

§3.2 The nature of the system

As mentioned above, the orthographic system discussed in this book is usually defined by scholars as “syllabic orthography” or “group writing” (e.g. Albright 1934; Zeidler 1991; Hoch 1994; Ward 1996; Peust 1999). Both these definitions are descriptive, and somehow legitimate: this orthography is indeed based on a set of “groups” of signs, and it does seem¹⁵ that each of such groups transcribed short sequences of consonants and vowels, i.e. “syllables”. If however one wants to describe such orthographic system from a functional, rather than descriptive, perspective, then I think that “rebus writing” would be a more suited name. As already noticed (e.g. by Hoch 1994, 501), various “groups” are in fact nothing but short mono- or biconsonantal words (either originally native or loanword) or morphological elements and particles that happen to be used to transcribe likely homophonic syllables or segments.¹⁶ This is evident from the fact that classifiers may be retained when such words are used in group writing, even though they have no semantic

15 Some scholars have expressed doubts against it. Various clues, however, suggest that the system is somehow “syllabic”.

16 Conceptually, such a “rebus writing” is not unique to Egyptian. A very similar principle underlies, for instance, the transcription of foreign words in Modern Chinese: “Italy”, for instance, is transcribed as 意大利 = *yidàlì*, which is essentially a sequence of three independent words, namely 意 = *yì* = “meaning”, “idea”; “to wish”, “to desire”, 大 = *dà* = “big”, “great” and 利 = *lì* = “sharp”, “convenient”; “profit”, which however are used purely for their phonetic value, rather than for their semantic meaning. The use of such “rebus writing” to transcribe foreign words, or even full sentences, is not a modern invention in Chinese, but is well attested also in the past. For instance, hundreds of similar transcriptions of Sanskrit terms are attested in Middle Chinese (Chen 2000), such as for instance Sanskrit *maṇḍala* was transcribed using the three characters/monosyllabic words 曼拏羅, which in Middle Chinese were pronounced *manH-nrae-la*, and originally meant “distant”, “to handle”, “kind of net” respectively (Chen 2000, 395, Middle Chinese pronunciation based on and transcribed according to Baxter 2014). The most advanced development of these system, however, is probably represented by the spelling of the so-called Secret History of the Mongols, an historical chronicle about the deeds of Genghis Khan, composed in Mongolian language

relation at all with the new word being spelled out. Let us consider, for instance, the word $\overline{\text{h}}\overline{\text{i}}\overline{\text{l}}\overline{\text{l}}\overline{\text{s}}$, “hill(s)”, < Semitic $\sqrt{t-l-l} = \text{til}(lu)$,¹⁷ whose spelling can be analysed as a rebus combination of the Egyptian word $\overline{\text{h}}\overline{\text{i}}\overline{\text{l}}\overline{\text{l}}\overline{\text{s}} t =$ “bread”, written with its full set of classifiers, and the Egyptian word $\overline{\text{h}}\overline{\text{i}}\overline{\text{l}}\overline{\text{l}}\overline{\text{s}} r\text{?} =$ “mouth”. Clearly, the classifiers of $\overline{\text{h}}\overline{\text{i}}\overline{\text{l}}\overline{\text{l}}\overline{\text{s}}$ have no semantic connection whatsoever with the word “hill”.

Another interesting example is the transcription of the Hurrian divine name Teshub, which appears in group writing as $\overline{\text{h}}\overline{\text{i}}\overline{\text{l}}\overline{\text{l}}\overline{\text{s}}\overline{\text{e}}\overline{\text{a}}$ (Hoch 1994, 258, no. 364). This spelling can be interpreted as a rebus composed of two elements. The first, $\overline{\text{h}}\overline{\text{i}}\overline{\text{l}}\overline{\text{l}}\overline{\text{s}} t(j)$, possibly originates from the second person stative suffix $-t(j)$. The second, $\overline{\text{h}}\overline{\text{i}}\overline{\text{l}}\overline{\text{l}}\overline{\text{s}}\overline{\text{e}}\overline{\text{a}}$, is not attested as an independent word but is present in other loans from Semitic languages. Leaving aside for a moment the position of $\overline{\text{e}}$ in the sequence, which will be discussed here below (§3.3, §4.1), this $\overline{\text{h}}\overline{\text{i}}\overline{\text{l}}\overline{\text{l}}\overline{\text{s}}\overline{\text{e}}\overline{\text{a}}$ can be identified with a Semitic verb meaning “to return” and attested in Biblical Hebrew as $\overline{\text{h}}\overline{\text{i}}\overline{\text{l}}\overline{\text{l}}\overline{\text{s}}\overline{\text{e}}\overline{\text{a}}$ and in Amorite as $\overline{\text{h}}\overline{\text{i}}\overline{\text{l}}\overline{\text{l}}\overline{\text{s}}\overline{\text{e}}\overline{\text{a}}$, from $\sqrt{\text{š-w-b}}$ (so Hoch 1994, 258, no. 364). Once again, the $\overline{\text{a}}$ is the classifier of such verb, and it is not semantically related in any way with the name of the Hurrian god. Moreover, the presence of such classifier shows that the sequence $\overline{\text{h}}\overline{\text{i}}\overline{\text{l}}\overline{\text{l}}\overline{\text{s}}\overline{\text{e}}$ as to be interpreted as a single group, as in fact scholars did, rather than as a combination of two distinct groups $\overline{\text{h}}\overline{\text{i}}\overline{\text{l}}\overline{\text{l}}\overline{\text{s}}$ and $\overline{\text{e}}\overline{\text{a}}$: $\overline{\text{a}}$ does make sense as classifier of $\overline{\text{h}}\overline{\text{i}}\overline{\text{l}}\overline{\text{l}}\overline{\text{s}}\overline{\text{e}}$, but it does not as classifier of $\overline{\text{e}}\overline{\text{a}}$ alone.

Words with a $C_1\text{-}C_2$ structure,¹⁸ like $\overline{\text{h}}\overline{\text{i}}\overline{\text{l}}\overline{\text{l}}\overline{\text{s}}\overline{\text{e}}\overline{\text{a}}$, are rather rare in New Kingdom group writing.¹⁹ At the time, the general tendency was to prefer words that in the traditional Middle Egyptian orthography would be analysed as $C_1\text{-}r$ (and rarely $C_1\text{-}j$) or $C_1\text{-}w$, such as $\overline{\text{h}}\overline{\text{i}}\overline{\text{l}}\overline{\text{l}}\overline{\text{s}}\overline{\text{e}}\overline{\text{a}}$ $\overline{\text{h}}\overline{\text{i}}\overline{\text{l}}\overline{\text{l}}\overline{\text{s}}\overline{\text{e}}\overline{\text{a}}$ $\overline{\text{h}}\overline{\text{i}}\overline{\text{l}}\overline{\text{l}}\overline{\text{s}}\overline{\text{e}}\overline{\text{a}}$.²⁰ The presence of the single stroke $\overline{\text{h}}$ or of classifiers such as $\overline{\text{h}}$ in $\overline{\text{h}}\overline{\text{i}}\overline{\text{l}}\overline{\text{l}}\overline{\text{s}}\overline{\text{e}}\overline{\text{a}}$ confirms that, conceptually, the Egyptians perceived these groups as *words*, and not just as mere *phonograms*.

In Egyptian, however, the number of words with $C_1\text{-}r$ or $C_1\text{-}w$ structures is limited, and they do not cover all the consonants of the language. In those cases where no suitable $C\text{-}r/w$ word exists, plain biliteral signs, sometimes combined with $\overline{\text{h}}$ or $\overline{\text{e}}/\overline{\text{a}}$, or alternatively

but written by using Chinese characters as purely phonetic, syllabic signs. For instance, the title of the first chapter reads as follows (see Rachewiltz 2004):

| | |
|--------------------------------------|---|
| Chinese text : | 成吉思合罕訥忽札兀兒 |
| Pronunciation: | <i>chéng-jī-sī há-hān-nè hū-zhā-wù-ér</i> |
| Reconstructed Middle Mongolian text: | <i>čingyis qayanu hujayur</i> |
| Meaning : | “(On) the origins of Gengis Khan” |

Conceptually, this system is very similar, if not even identical, to the Egyptian use of the group writing to transcribe sentences in foreign languages, such as in Pap. Anastasi I 23,5.

17 Akkadian *tillu*, Hebrew *tell*, Aramaic *till*, Syriac *tell*, Arabic *tall* – see Hoch 1994, 356–7, no. 527.

18 Where C = any consonant except r or w .

19 While they are more frequent in earlier forms of group writing.

20 It has often been suggested that the sign $\overline{\text{h}}$ was used to transcribe a third group of syllables, usually interpreted as $C_1\text{-}y$. I however disagree with this idea, as I think the evidence show that the $\overline{\text{h}}$ had other functions. I discuss this aspect more in detail later, in §4.2.

Therefore, for now, I focus only on $C_1\text{-}r$ ($C_1\text{-}j$) and $C_1\text{-}w$ groups, which constitute the basic framework of the group orthography, as I think it will appear from this study.

combination of unilateral signs if no corresponding biliteral sign was available either, could be used instead.

Single consonantal signs could also be used in the spelling of biconsonantal words (such as $\text{𓂏}^{\text{e}}\text{𓂏}$ just mentioned), as phonetic complements for specific groups (such as $\text{𓂏}^{\text{e}}\text{𓂏} = b-p\text{-}z = b\text{-}z$) or individually. When full words or biliteral signs are available, they are clearly preferred to combinations of unilateral signs, as it appears from Hoch index of groups (Hoch 1994, 506–12). For instance, 𓂏^{e} and 𓂏^{e} are by far the most common spellings of the groups fz or rw , although in theory $\text{𓂏}^{\text{e}}\text{𓂏} = \text{f} + \text{z}$ or 𓂏^{e} $r + w$ would have been equally valid alternatives.

Naturally, these have to be understood as overall trends, not as absolute rules. The system was clearly not fully standardised, exceptions do exist, and a certain degree of voluntary or involuntary freedom was present. Therefore, it has to be expected that at times the same consonantal sequence could be written either with a full word, with a biliteral sign, or with a combination of unilateral signs.

Nevertheless, these theoretical considerations are crucial, because understanding how the Egyptians themselves conceived and perceived the group writing can help understand how it functioned.

§3.3 The number of vowels

In a previous article (Kilani 2017a) I have argued that the so-called space filler $\text{e} = w$ present in Late Egyptian texts was a sort of vowel marker used to give a general indication on the nature of the tonic vowel of the word. The system underlying such w -extended orthography²¹ was rather rudimentary, and was characterised by two basic principles. First, the quality of only the stressed vowel was represented, and only two basic qualities, *non-back* and *back*,²² could be indicated by the presence or absence of the e respectively. Second, this vowel marker e worked somehow as a classifier, in the sense that it was written at the end of the word, after any consonant and independently from the actual position of the stressed vowel within the word. Therefore, a form like 𓂏^{e} must be interpreted as *consonants + vowel marker*, that is as $hpr + w \Rightarrow hwpr$, corresponding to Coptic ϣϣϣ (see Kilani 2017a, 189). The reasons for such a system, and especially for the latter feature, which may appear rather counterintuitive or at least unpractical, may have to be searched in the specificities of the vocalisation of Late Egyptian, and in the nature of the Egyptian writing. In particular, it is likely that Late Egyptian, like Coptic, had only one distinctive vowel, namely the tonic one, while all the other unstressed vowel were reduced and realised either as [ə] or, in some specific phonetic environments, as [a]. This means that only one vowel was worth being indicated, and therefore only one vocalic marker was needed for the whole word. At the same time, the fact that many hieroglyphic signs simultaneously encoded for more than one consonant, made it often practically impossible to indi-

21 I do not call it like this in the article, in fact, I do not provide any specific definition, but it can be useful here.

22 In the article I refer to them as *front* and *back* vowels. However, now I think that it is more accurate to refer to them as *back* and *non-back*. See below note 26.

cate the presence of a vowel there where it was supposed to be pronounced. For instance, as explained in Kilani 2017a, in the case of a verb like ⲛⲓⲣ = *hpr*, “to exist”, Coptic ⲩⲣⲟⲛⲉ, it would be impossible to introduce a vocalic marker *w* between the “*h*” and the “*p*” to indicate the vowel “*o*” at its actual position, because the two consonants are written together with the single, indivisible trilateral sign ⲛⲓⲣ.

If one considers that in hieratic writing some ligatures may also have been perceived as indivisible groups or “schematograms”,²³ then one may understand why writing the vowel marker *w* after all the consonants often was not a choice, but rather the only possible option.²⁴

This *w*-extended orthography is relevant here, because it can be argued that the same principles governing it were also at the basis of group writing. In fact, if one considers that the groups of group writing were likely perceived as *words* within a rebus-based system, rather than just as elements of a phonetic syllabary, then one can expect them to abide to the same principles governing the spelling of ordinary words, including those underlying the *w*-extended orthography. These considerations constitute the basis for the interpretative model presented here.

23 Junge 2005, 38–9 – This is likely the case for words like ⲛⲓⲣⲟⲛⲉ, where the sequence of signs ⲛⲓⲣⲟⲛⲉ may have been perceived as an indivisible schematogram, thus prompting a spelling ⲛⲓⲣⲟⲛⲉ = *htw* + *w* => *htwm*, corresponding to Coptic ⲩⲣⲟⲛⲉ (see Kilani 2017a).

24 One has to remember that this system was used by people who knew the language natively. Therefore, its main aim was probably to avoid ambiguities or as an aid-memoir to facilitate the recognition of words otherwise written only consonantally, rather than to allow readers unacquainted with the language to properly vocalise new, unknown words.

§4 Group writing – A new model

The following sections are structured as follow: first I introduce the general principles on which the proposal is based and I discuss a few special cases.

The proposal will then be systematically verified against the evidence from the corpus.

After that, the evidence is analysed diachronically. Some words are attested in different periods, and therefore it is possible to have a closer look at the evolution of their vocalisation. The identification of expected patterns of vocalic evolution can be used as a confirmation of the validity of the model here presented.

A statistical assessment of the results is then presented, while some special cases are further discussed after that.

A general conclusion follows.

§4.1 Definition of the interpretative model

The interpretation of group writing²⁵ I present here is based on the two following principles, which directly derive from the *w*-extended orthography:

- Groups encode only 2 vowels, or better 2 vocalic classes: *back* and *non-back*.²⁶
The presence of *-w* corresponds to the presence of a *back* vowel. In order to mark

25 In spite “rebus writing” would be conceptually more appropriate, in this study I will stick to the traditional definitions of syllabic orthography and group writing, just to avoid another superfluous label to this writing system.

26 As suggested by a reviewer, since one of these vocalic classes seems to correspond to the stressed vowels /a/, /e/, /i/, while the other to the vowels /o/, /u/, in theory one may also interpret the underlying opposition as a question of roundedness/labialisation, that is as unrounded vs rounded. I think this may indeed be a valid alternative. However, I still prefer to interpret it as an opposition back vs non-back for two reasons. First, it is usually assumed that the articulatory position of a vowel is more distinctive than its roundedness (this is evident, for instance, from the fact that vocalic inventories of languages are usually described according to the position of the vowels, rather than according to their roundedness – this is also the case of descriptions of Egyptian, see for instance Loprieno 1995, passim). Moreover, there may be evidence from Coptic suggesting that the Egyptian themselves did not consider roundedness as a main distinctive feature of their vowels. In particular, as mentioned above (§3.1), it has been suggested that Coptic *h* was actually used to transcribe two distinct phonemes, possibly corresponding to an unrounded /e:/ and a rounded /ø:/ (Peust 1999, 228–30). If this is the case – and I do not see any concrete reason to question it –, then the fact that the same letter *h* was used for both would suggest that, at least in the Coptic period, Egyptians were not distinguishing their vowels on the basis of roundedness, because roundedness is actually the only main feature distinguishing the vowels /e:/ and /ø:/. Naturally, it is clear that an orthographic feature of Coptic does not tell us anything, directly, about the Late Egyptian orthography. However, I think one may expect at least some degree of continuity in the underlying perception of the speakers of the language. In particular, if Late-Egyptian/pre-Coptic speakers did perceive roundedness as a main distinctive feature of their vowels, it might be expected that, when the Greek alphabet was adopted to write Egyptian, an attempt would have been made to try to mark such a distinction, also (and perhaps especially) in the vowels /e:/ and /ø:/. This, however, is clearly not the case, which suggests that in the underlying pre-Coptic perception, roundedness was not a main distinctive feature.

such *back* vowel, I use the transliteration *U*. The absence of *-w*, or the presence of *-ʒ* indicate either the presence of a *non-back* vowel or the *absence* of any vowel. I mark it with *A* or *∅*.

- The *-w* is written after the consonant of its group, but it can be read both before or after it. This is because the *-w* works like a classifier, like in the *w*-extended orthography. Therefore a group *c-w*²⁷ can be read either as *cU* or as *Uc*.

The possibility that only two vowels, rather than three, were encoded had already been implicitly suggested for the group writing of the Middle Kingdom (see Hoch 1994, 496–7 with refs). No one, however, seems to have considered that this principle may apply to later periods as well, possibly because of the common assumption that the sign “ must have also been a vocalic marker.

An interpretation based on only 2 vowels, however, is strongly supported by the evidence. As it is discussed more in detail below (§5), it can be shown that all the forms of the corpus can be explained on the basis of a two vowels system, with each group having only one vocalic value. None of the systems with three vowels suggested so far is comparably coherent.

As for the *-w* in group writing working like the *-w* in *w*-extended orthography, a first confirmation comes from the transcription of the name of the god Tešub mentioned above. As said, the spelling 𐎢𐎠𐎠𐎡𐎢 can be analysed as composed of two groups, 𐎢𐎠 and 𐎠𐎡𐎢 . The first can be read as *tA = tA*, where *A = non-back* vowel, which is the expected transcription of the first syllable of the name, *te-*.

The second group, 𐎠𐎡𐎢 , instead, transcribes the syllable *-šub*. It is clear that if we read it as it is written, namely *sbw*, then the spelling cannot be reconciled with the pronunciation of the syllable it is supposed to transcribe. If instead we assume it was spelled according to the *w*-extended orthography, then it can be read as *sb + w = sb + U*, where *U = back vowel*, and it can be normalised as *sUb*, the expected transcription for the syllable *-šub*. A reading *sUb* would also fit as a transcription of a verb /sub/ < Semitic *šūb* = “to return”, which as mentioned above has been suggested by Hoch, on the basis of the classifier, as the source of the group 𐎠𐎡𐎢 .

𐎠𐎡𐎢 is a C_1C_2+w group, but the same principle may be applied to $C+w$ groups, which can thus be analysed either as $C+w = C + U = CU$ or $C+w = C + U = UC$.

This suggestion is supported by two words, attested in the corpus in two variants. They are the following:

| | <i>Variant 1</i> | <i>Variant 2</i> |
|--------------------------------|------------------|------------------|
| <i>šnrr</i> , “pebbles” (II.4) | 𐎢𐎠𐎠𐎡𐎢 | 𐎢𐎠𐎠𐎡𐎢 |
| <i>šbd</i> , “rod” (II.34b) | 𐎢𐎠𐎠𐎡𐎢 | 𐎢𐎠𐎠𐎡𐎢 |

The spellings 𐎢𐎠𐎠𐎡𐎢 and 𐎢𐎠𐎠𐎡𐎢 can be assumed to be equivalent, as they are both attested in the same period and they are both singular, and therefore morphologically

27 Where *c* = any consonant.

identical (see Appendix A below for details). We can therefore assume that they aim at transcribing the same phonological sequence. This means that the groups $\text{w} \text{w}$ and w must be equivalent as well, and they also must transcribe the same phonological sequence.²⁸ This is possible only if we assume that the group $\text{w} = r+w$ can be read both as $r+U = rU$ and as $r+U = Ur$, so that:

$$\text{w} = (r+z) + (r+w) = (r+0) + (r+U) = r0 + Ur = rUr$$

and: w

$$\text{w} = (r+w) + (r+z) = (r+U) + (r+0) = rU + r0 = rUr^{29}$$

The same considerations apply also to the second case: since w and w are morphologically the same, and come from the same period, they can be assumed to transcribe the same phonological sequence. Therefore, the groups w and w must be equivalent. This is possible only assuming that $\text{w} = d(t)+U = Ud$,³⁰ so that:

$$\text{w} = (b+w) + (d) = (b+U) + (d+0) = bU + d0 = bUd$$

and:

$$\text{w} = (b) + (d(t)+w) = (b+0) + (d+U) = b0 + Ud = bUd$$

These variants are relatively rare, possibly because some orthographic rules or conventions may have existed within the system (see below §7).

It may appear counterintuitive that a same sign encodes for both *CV* and *VC* sequences,³¹ as this is certainly not a common behaviour in attested scripts around the world. Nevertheless, a few parallels do exist. The first can be found in cuneiform Hurrian, where the sign *WA* can be used to write both the syllables /wa/~/we/ and the syllable /aw/~/ew/.³² In addition, a few examples may suggest a similar behaviour also for the *alif+i* sign in the Ugaritic alphabet,³³ but this case is more controversial (Bordreuil and Pardee 2010, 37 with refs). More important, the same phenomenon, where the reading order of the sign is inverted in respect to their writing order, is attested also in Late Egyptian, for instance in BM EA 10474 (*Teachings of Amenemope*), where the sequence w corresponds to both *w* and *tw* (Laisney 2007, 10).

On these theoretical bases, the system can be analysed in more details. I will do so in §5–6. First, however, a few special cases need to be introduced.

28 I.e. the same sequence of consonants and vowels, in the same order and with the stress in the same position. Obviously, it cannot be excluded that such consonants and vowels may have been phonetically realised in slightly different ways, if different dialects were involved, but this is not relevant here, as such variations would not affect the order of the phonemes themselves.

29 For the reading $\text{w} = r+z = r+0 = r0$ see below.

30 For $\text{w} = w$ and therefore $\text{w} = d(t)+U = dU/Ud$ see Kilani 2017a, 200–1.

31 Where *V* = vowel.

32 E.g. the spelling *WA-ri* stands for *ew-ri* /evri/ Wegner 2007, 45.

33 Which seems to encode for both /ʔ/ + /i/ and /i/~/a/~/u/ + /ʔ/.

consonants. These groups are $\overset{\circ}{\text{Ⲁ}}$, encoding for $-r:(C-)$ or $-r\#$ and $\overset{\circ}{\text{Ⲁ}}$, which I transcribe as n_l , encoding for $-n:(C-)$ or $-n\#$.³⁴

These groups appear to be different from standard $\overset{\circ}{\text{Ⲁ}} = r-ʒ$ and $\overset{\circ}{\text{Ⲁ}} = n-ʒ$ groups, in that they explicitly always correspond to $r+0(+C/\#)$ and $n+0(+C/\#)$ and never to $r+A$ and $n+A$.

To mark the peculiarity of these groups, in the following paragraphs I transliterate them as $rʒ$ and n_l and I parse them as r and n respectively.

The fact that these two consonants enjoy such a special status and treatment has parallels in other syllabic scripts.³⁵ This exceptionality is probably due to their phonological nature, which seems to have induced various scribal cultures to perceive them as somehow different from other consonants.³⁶

Usually, modern scholars have assumed an implicit identity between phonological syllables and written syllables in Egyptian group writing, and therefore have interpreted the groups $\overset{\circ}{\text{Ⲁ}}$ and $\overset{\circ}{\text{Ⲁ}}$ as transcribing consonants in coda of (phonological) syllables, as it appears from the conventions adopted in transliterating them (Albright 1934, 47, 50; Helck 1971, 552–3; Schneider 1992, passim; Hoch 1994, passim).

These assumptions, however, have never been demonstrated on the basis of any evidence. In fact, another scenario seems to emerge from the data, which suggested that, rather than codas of previous syllables, such groups should be interpreted, from the perspective of the functioning of the script, as clustered with the following consonant.

In other words, I think the evidence shows that a sequence $CV + rʒ/n_l + CV$ was not interpreted by the Egyptian as $CVr/n.CV$, as usually modern scholars do, but was rather conceptually perceived as $CV.rCV$ and $CV.nCV$. By analogy, it is likely that also when they are the last groups of a word, $\overset{\circ}{\text{Ⲁ}}$ and $\overset{\circ}{\text{Ⲁ}}$ must be interpreted as $CV.r\#$ and $CV.n\#$, rather than as $CVr\#$ and $CVn\#$.

This can be inferred from the following spelling variants attested in the corpus (II.3):

| <i>Variant 1</i> | | <i>Variant 2</i> |
|---|----|---|
| $\overset{\circ}{\text{Ⲁ}} \overset{\circ}{\text{Ⲁ}} \overset{\circ}{\text{Ⲁ}} \overset{\circ}{\text{Ⲁ}} \overset{\circ}{\text{Ⲁ}}$ | a) | $\overset{\circ}{\text{Ⲁ}} \overset{\circ}{\text{Ⲁ}} \overset{\circ}{\text{Ⲁ}} \overset{\circ}{\text{Ⲁ}} \overset{\circ}{\text{Ⲁ}}$ |
| | b) | $\overset{\circ}{\text{Ⲁ}} \overset{\circ}{\text{Ⲁ}} \overset{\circ}{\text{Ⲁ}} \overset{\circ}{\text{Ⲁ}} \overset{\circ}{\text{Ⲁ}}$ |

All these forms can be interpreted as transcriptions of $/ʕul/$, from which Coptic $\Delta\lambda /(?)\text{al}/$ derives. The spelling of Variant 1 is transparent:

$$\overset{\circ}{\text{Ⲁ}} = \zeta \qquad \overset{\circ}{\text{Ⲁ}} = w = \textit{back vowel } U \qquad \overset{\circ}{\text{Ⲁ}} \overset{\circ}{\text{Ⲁ}} \overset{\circ}{\text{Ⲁ}} \overset{\circ}{\text{Ⲁ}} \overset{\circ}{\text{Ⲁ}} = n_l + rʒ = l$$

34 Where C = consonant of the following group, and $\#$ = end of word.
 35 For instance, Japanese kana syllabaries have exclusively CV signs for all consonants but $/n/$, while in most cases Indian devanagari treats $/r/$ as a modifier of other CV signs, rather than just as an independent consonant.
 36 I do not know if such a phenomenon has ever been investigated from a wider ethno-anthropological perspective. Whether it has or not, I think it would be interesting to look at it integrating the Egyptian data. It is clear, however, that such a study is far beyond the scope of the present study.

which gives $\zeta U . n r 0 = \zeta U . l = \zeta U l$, the expected transcription for $/\zeta ul/$.

The spelling of Variant 2), needs more attention. If we assume that the signs $\overset{\sim}{\underset{\sim}{\text{C}}}_1$ and $\overset{\sim}{\underset{\sim}{\text{C}}}_1$ have to be read as codas of the previous syllables, as it has been suggested so far, then we obtain:

Variant 2a):

| | Syllable 1 | Syllable 2 |
|------------------------|---|---|
| <i>Attested form</i> | $\overset{\sim}{\underset{\sim}{\text{C}}}_1$ | $\overset{\sim}{\underset{\sim}{\text{C}}}_1$ |
| <i>Transliteration</i> | $\zeta 3 + \text{r} \zeta$ | $r w$ |
| <i>Normalisation</i> | $\zeta A r$ | $r U = l U$ |

Variant 2b):

| | Syllable 1 | Syllable 2 |
|------------------------|---|---|
| <i>Attested form</i> | $\overset{\sim}{\underset{\sim}{\text{C}}}_1$ | $\overset{\sim}{\underset{\sim}{\text{C}}}_1$ |
| <i>Transliteration</i> | $\zeta 3 + n_l$ | $r w$ |
| <i>Normalisation</i> | $\zeta A n$ | $r U = l U$ |

Note that in both cases $\overset{\sim}{\underset{\sim}{\text{C}}}_1 = r w$ cannot be read as $U r$, because $\overset{\sim}{\underset{\sim}{\text{C}}}_1 = -r$ and $\overset{\sim}{\underset{\sim}{\text{C}}}_1 = -n$ imply a consonant just after them.

These transcriptions would thus yield, respectively:

$$\overset{\sim}{\underset{\sim}{\text{C}}}_1 + \overset{\sim}{\underset{\sim}{\text{C}}}_1 = \zeta A r + r U = \zeta A r . r U = \zeta A l U$$

$$\overset{\sim}{\underset{\sim}{\text{C}}}_1 + \overset{\sim}{\underset{\sim}{\text{C}}}_1 = \zeta A n_l + r U = \zeta A n_l . r U = \zeta A l U$$

Both those readings would be problematic, both because they do not correspond in any way to the reading implied by Variant 1 and because they do not correspond to neither SBA $\lambda \lambda$ nor $F \epsilon \lambda$ (Crum 1939, 3).

If however we assume that the signs $\overset{\sim}{\underset{\sim}{\text{C}}}_1$ and $\overset{\sim}{\underset{\sim}{\text{C}}}_1$ should be read as clustered with the following consonants, then the following interpretations become possible:

Variant 2a)

| | Syllable 1 | Syllable 2 |
|------------------------|---|---|
| <i>Attested form</i> | $\overset{\sim}{\underset{\sim}{\text{C}}}_1$ | $\overset{\sim}{\underset{\sim}{\text{C}}}_1 \overset{\sim}{\underset{\sim}{\text{C}}}_1$ |
| <i>Transliteration</i> | $\zeta 3$ | $\text{r} \zeta + r w$ |
| <i>Normalisation</i> | $\zeta 0$ | $r r - U = \text{r} r U / U r = l U / l U$ |

Variant 2b):

| | Syllable 1 | Syllable 2 |
|------------------------|-----------------------|---|
| <i>Attested form</i> | $\overline{\text{Ⲁ}}$ | $\overline{\text{Ⲁ}} \overline{\text{Ⲁ}}$ |
| <i>Transliteration</i> | ʕ | $n_l + r_w$ |
| <i>Normalisation</i> | ʕ0 | ${}^n r-U = {}^n rU / U^n r = lU / Ul$ |

Which in both cases can be read as, respectively:

$$\overline{\text{Ⲁ}} + \overline{\text{Ⲁ}} \overline{\text{Ⲁ}} = ʕ0 + U^r r = ʕ0.U^r r = ʕ0.Ul = ʕUl = /ʕul/$$

$$\overline{\text{Ⲁ}} + \overline{\text{Ⲁ}} \overline{\text{Ⲁ}} = ʕ0 + U n_l r = ʕ0.U n_l r = ʕ0.Ul = ʕUl = /ʕul/$$

Which corresponds to Variant 1 $\overline{\text{Ⲁ}} \overline{\text{Ⲁ}} \overline{\text{Ⲁ}}$ and which is the expected transcription of /ʕul/.

The validity of such analysis is supported by two other words of the corpus, namely $\overline{\text{Ⲁ}} \overline{\text{Ⲁ}} \overline{\text{Ⲁ}} = mrh$ and $\overline{\text{Ⲁ}} \overline{\text{Ⲁ}} \overline{\text{Ⲁ}} = h_2rd$, which correspond to Coptic $\text{ⲙⲉⲣ}(e)\text{ⲗ}$ (and variants) = *m'er(a)h* and $\text{ⲕⲟⲣⲧ} = \text{š'ort}$ respectively.

$\overline{\text{Ⲁ}} \overline{\text{Ⲁ}} \overline{\text{Ⲁ}} = mrh$ is attested in Period 1 and 2. The word is related with Semitic *rumh* (see below §6) and its pronunciation in Egyptian can be reconstructed as **murhv* in both periods. Its spelling, therefore, can be interpreted as follow:

$$\overline{\text{Ⲁ}} \overline{\text{Ⲁ}} \overline{\text{Ⲁ}} = m0 + {}^r h-U = m0 + U^r h = mU^r h$$

$\overline{\text{Ⲁ}} \overline{\text{Ⲁ}} \overline{\text{Ⲁ}} = h_2rd$ is instead attested in Period 3, and therefore its pronunciation at the time can be reconstructed as **h₂'ord(v)*. Its spelling can be parsed as:

$$\overline{\text{Ⲁ}} + \overline{\text{Ⲁ}} \overline{\text{Ⲁ}} \overline{\text{Ⲁ}} = h_20 + {}^r d-U = h_20 + U^r d = h_2U^r d^{37}$$

Again, taking $\overline{\text{Ⲁ}} = {}^r r$ as the coda of the previous syllable would not work, as it would lead to a reading $\overline{\text{Ⲁ}} \overline{\text{Ⲁ}} \overline{\text{Ⲁ}} = mA + {}^r + h-U = mA^r + hU = mA^r hU$ and $\overline{\text{Ⲁ}} \overline{\text{Ⲁ}} \overline{\text{Ⲁ}} = h_2A-{}^r r + d-U = h_2Ar + dU = *h_2ArdU$, which cannot be reconciled in any way with the attested Coptic forms.

These written consonantal clusters can be phonemic, i.e. they can represent a real combination of two distinct phonemes, or can be merely orthographic, i.e. they can be a conventional combination of two graphemes used to write a different phoneme, which is not independently represented within the range of available signs. This seems to be especially the case with the sign $\overline{\text{Ⲁ}}$ which can be combined with a following *r* to form a digram corresponding to Coptic λ and thus probably representing /l/.

It has to be noted that the syllabification dictated by these signs is a phenomenon that takes place at the writing level, and it is therefore independent from the actual syllabic and prosodic patterns characterising these words at a purely linguistic level. Similar discrepancies between the intrinsic linguistic syllabification of words and the functional syllabification rules commanding their written representation are attested in various writing systems around the world. English orthography, for instance, implements syllabification rules that are unrelated with the actual linguistic syllabic structure of the words they

37 For $\overline{\text{Ⲁ}}$ = dU/Ud see below §4.5.2.

represent,³⁸ while Indian devanagari (and essentially all South East Asian scripts derived from them) clusters up together all adjacent consonants irrespectively of any linguistic syllabic boundary.³⁹ In the latter, the resulting orthographic conventions appear to be, in this respect, conceptually and functionally very similar to what can be observed in the Egyptian group writing.

§4.4 ◌ in final position

By the end of the Middle Kingdom the *-t* ending of feminine, usually written ◌ was not pronounced any longer. The use of ◌ in final position, however, survives in later periods, often but not exclusively in feminine words, and it is occasionally attested also in words written in group writing. In many cases this vestigial ◌ may have been just a graphic phenomenon, possibly reinterpreted as a semantic marker of feminine grammatical gender. The evidence from the corpus used in the present study, however, seems to suggest that in other cases it may have retained some phonetic significance, and may have developed into a marker for /ə/ at the end of words. Such a development would not be surprising, as the disappearance of the feminine ending *-t* caused the previous usually unstressed vowel to appear in final position as a /ə/.

This considered, in the present study I transliterate this final ◌ as *t_i*, and I parse it as *ə*, thus for instance: = *šnt_i* = *šA.n0.f0.ə* = *š 'i/unfv = *ʁ(ε)ŋqe*.

This, however, has to be considered as a somehow conventional solution, and it has to be kept in mind that the presence of the ◌ may be a purely graphic phenomenon, with no phonetic meaning at all. Further studies, on a larger and more specific corpus, are needed to better determine the uses and functions of this final ◌ in Late Egyptian.

§4.5 Special readings for two groups

Two groups need special attention, as they appear to have a phonetic value that is in contrast with that which could be inferred from the sheer reading of their consonants.

§4.5.1 *kʒ* and the development of /a/ in proximity of /k/

It has long been suggested (see e.g. Allen 2013, 25) that in spite of its aliph, the sign 𓀀 = *kʒ* was pronounced with a *back* vowel already in Period 1 and 2, that is before the supposed date of the general /'a/ > /'o/ vocalic shift, which is usually dated between Period 2 and Period 3 (see above §3.1). The most compelling evidence is provided by the cuneiform transcription *kuʔihku* for Egyptian *kʒ-hr-kʒ* = *κοιαζκ* (S). Allen (2013, 25) has suggested that this pronunciation could be an early attestation of the /a/ > /o/ shift, limited to some specific phonetic environments. The present study confirms these observations, and shed some possible light on the phonetic conditions where such early shift took place.

38 For instance, the English word “learning” is syllabised as *learn-ing* in writing, although phonological its syllabic structure is rather /'lɜ:/ + /nɪŋ/.

39 For instance in Sanskrit a word like *śikṣak* = “teacher”, whose phonological syllabic structure is obviously *śik* + *ṣak*, is actually written शिक्षक, i.e. शि *śi* + क्ष *kṣa* + क *k(a)*, where क्ष = *kṣa* is graphic ligature of the sign क *ka* + ष *śa*.

| item | Period I | | | Period II | | | Period III | | |
|---------|----------|-----------------------------------|---------------|-----------|-----------------------------------|---------------|------------|-----------------------------------|---------------|
| | id | expected vocalisation at the time | attested form | id | expected vocalisation at the time | attested form | id | expected vocalisation at the time | attested form |
| chariot | I.7 | *mvrk' abtv | | III.15 | *mvrk' abtv | | III.7 | *mvrk' obtv | |
| mrrkbt | | | | | | | | | |
| palm | | | | II.40 | *k' ap | | III.20 | *k' op | |
| kp | | | | | | | | | |
| a jar | I.1 | *ʔvik' a:nv | | | | | | | |
| jkn | | | | | | | | | |

Various words whose Coptic descendants display a vowel /o/ are attested in the corpus during Period 1 and Period 2. The group writing form of many of them⁴⁰ implies a *non-back* vowel, thus showing that, as expected, the /'a/ > /'o/ shift did not take place yet. An example could be *ym* = “sea”, which is spelled as = *y' am > εΙΟΜ (I.2, II.2) in Period 1 and 2 and therefore does not display any *back* vowel, but which does present a spelling with *w* = *U* in Period 3, after the shift had taken place, as it appears from the form = *y' om > εΙΟΜ (Period 3, III.2).

The spelling of three other words, however, indicate the presence of a *back* vowel also in periods when an /'a/ or /'a:/ would be expected.

To which we can add the abovementioned Cuneiform *kuʔihku* for Egyptian *k3-ḥr-k3* = κοια2κ (S).

The use of *U* in the spelling of in Period 1 suggests that such phenomenon was not limited to /a/ > /o/, but affected also the shift /a:/ > /o:/, a shift that in normal condition took place only after Period 1.

Even though the evidence is rather scanty, one feature seems to emerge: all the forms characterised by such unexpected *back* vowel present a velar consonant /k/ just before it.⁴¹

It can therefore be suggested that in general /'a:/ > /'o:/ after Period 1 and /'a/ > /'o/ after Period 2 except after /k/, where such shifts may occur earlier, already or even before Period 1, at least in some words.⁴²

To investigate the reasons for such an early shift in such a phonetic environment is beyond the scope of this study. Some preliminary ob-

40 Their full list is given below (§5.1–2) and in Appendix A.

41 Which often evolves into σ = /ki/ in Coptic.

42 The conditional here is due, because three attestations are hardly enough to generalise the phenomenon.

As said above, the ʿ sign is used here to mark a somehow non-standard pronunciation of the sign $\text{𓂏} = d$. The use of this alternative group $\text{𓂏} = d^y$ to transcribe the syllable d/tU , instead of $\text{𓂏} = tw$, which would have been the obvious candidate, could have emerged from the need of preventing ambiguity, as the group $\text{𓂏} = tw$ fulfils already other linguistically distinct functions in the Late Egyptian orthography.⁴⁴ The reasons for choosing specifically the group $\text{𓂏} = d^y$, and the origins of its apparent value with *back* vowel, however, escape me.

For further discussion on this group 𓂏 , see below §11.

44 Such as e.g. stative ending (Junge 2005, 82), basis for the pronoun set of the adverbial sentence (Junge 2005, 101–12) connector for suffix pronouns after syllable-final *-t* (Junge 2005, 52).

§5 Group writing – Data and analyses







All the forms attested in the corpus are discussed in the following paragraphs according to a division by period and by the nature of the stressed vowel in the contemporary pronunciation. Cases involving a /k/ + /a~/o/ are discussed separately for each period.



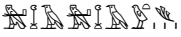

§5.1 Period 1

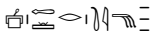
• NON-BACK VOWELS





In Period 1, 15 words with a stressed *non-back* vowel are attested. All of them are written without *w*. In 5 of them, the stressed vowel could be reconstructed both as a *non-back* /i/ or a *back* /u/. The spelling of the Egyptian forms, however, clearly points to a *non-back* vowel. Related Semitic forms are identifiable for one of them, and they support this interpretation (see below §6 for a throughout discussion of Semitic forms related the words of the corpus):

Egyptian /a/ = A > Coptic o; Egyptian /a:/ = A > Coptic ω

| | | | | | |
|------|-----------------------|--|--|----------------|---|
| I.2 | sea |  ym | yA.m(A) ↓ yAm(A) | *y'am | εΙΟΜ j'om |
| I.4 | a fish |  bry | bA.yr0.yA ↓ bAr(yA) | *b'ar(yv) | ϸ/φ/ΒΟΡΙ (B/B/S) ΒΟΡΕ (S) b'orə b'o:rə |
| I.8 | flowers (purslane) |  mh̄mh̄wt _i | mA.ḥ0.mA.ḥ.w _i 0.ə ↓ mAḥmAḥw _i ə | *mvḥm'ahwv | *μεζημοzyε *məhm'ohwə |
| I.9 | stronghold |  mktr | mA.k0.tA.r(A) ↓ mAktAr(A) | *mvkt'a(:)l(v) | μεστο/ωλ (B/S) mək't' o/o:l |
| I.16 | wool, hair |  sʕrt | sA.ʕA.r0.tA ↓ sAʕArtA | *svʕ'artv | ϸΟΡΤ s'ort |
| I.17 | lotus |  srpt | sA.yr0.pA.t ↓ sArpAt | *svrp'at | ϸΑΡΤ/ΦΟ/ΔΤ (O/B) sārp'ot |

| | | | | | |
|------|-------------------------|---|-------------------------|------------------------|---------------------------------|
| | | | šA.bA.d0.ə | | ϣϣⲟⲩ (B) |
| I.18 | staffs, rods (pl.) |  šbd(t ₁) | ↓ | *švb'adyv *švb'a:dv | ϣϣⲟⲩⲧ (S) šəb'otə šəb'o:t |
| | | | šAbAdə | | |
| I.19 | father/mother in law |  šm | ↓ | *š'am | ϣϣⲟⲩⲙ š'om |
| | | | šAm | | |
| I.23 | vessel for unguent |  krr | ↓ | *kvl'a:lv | κϵλⲱλ kəl'o:l |
| | | | kA.rA.rA kArArA | | |
| I.24 | couch, bed |  krkr | ↓ | *kvl'ak(kvrv) | ϭλⲟϭ k'əl'okj |
| | | | kU.rA.kU.rA kArAkUrA | | |

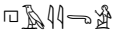
Egyptian /i/,/u/ = A > Coptic α, ε, 0; Egyptian /i:/,/u:/ = A > Coptic η

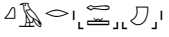
| | | | | | |
|------|-------------------------|--|----------------------|--|-----------------------|
| I.3 | branch of date- palm |  bšyt ₁ | ↓ | *bvš'i:u:y(wv) > *bv'y'i:u:š(wv) | βⲁⲛⲏⲛ (pl.) bāj'e: |
| | | | bA.šA.y0.ə bAšAyə | | |
| I.5 | pail, bucket |  bs | ↓ | *b'i:u:sv | βⲏⲥⲉ b'e:sə |
| | | | bA.sA bAsA | | |
| I.10 | husband |  hy | ↓ | *h'i/uy | Ⲓⲁⲓ h'aj |
| | | | hA.y0 hAy | | |
| I.20 | scale of fish |  šnft ₁ | ↓ | *š'i/unfv | ϣ(ϵ)ⲏϥⲉ š'enfə |
| | | | šA.n0.f0.ə šAnfə | | |
| I.22 | shield |  qrš | ↓ | *q'i/ulšv < Sem. *qilšv | ϭ(ⲁ)λ k'i'al |
| | | | qA.r0.šA qAršA | | |

• BACK VOWELS

9 words are spelled with $w = U$ in correspondence of their stressed vowel. In all of them, the stressed vowel could be reconstructed both as *non-back* or *back*, but the Egyptian spelling clearly point to a *back* vowel. The Semitic evidence, available for 3 of them, supports such interpretation (§6).

3 of these words are written with a $w = U$ in the actual position of the vowel, in the form $c-w + c = cU + c = cU.c$.







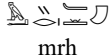

In 4 cases the $w = U$ is written after the consonant following the vowel, that is as $c + c-w = c + Uc = c.Uc$.

In 1 case, $w = U$ follows a cluster $r+c$, in the form $c + {}^r + c-w = Urc = c.Urc$.

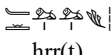
Finally, 1 case is written according to the form $c-w + c-w = cU + Uc = cUc$.

The attestations are summarised in the following table:

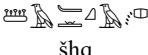
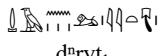
Egyptian /i/,/u/ = U > Coptic α, ε; Egyptian /i:/,/u:/ = U > Coptic η, ι

| | | | | | |
|------|--------------------------|---|---|------------------------------------|---|
| I.6 | spear, javelin |  mrḥ | m0.U ^r rh ↓ mUrḥ | *m' i/urḥv < Sem. *murḥv | μερ(ε)ρ μερε/ηρ m' erəh mər' e:h |
| I.11 | law(s) |  hp | h0.Up ↓ hUp | *h' i/up | ζαπ h' ap |
| I.12 | flower |  ḥrr(t) | ḥU.rU.Ur ↓ ḥUrUr | *ḥvr' i:/u:rv | ζρηρε hr' e:rə |
| I.13 | beetle, worm |  ḥrrw(t) | ḥA.rU.r0.w ₁ A ↓ ḥArUrw ₁ A | *ḥvl' i:/u:lwv | *ζαλελυε (A) hāl' elwə |
| I.14 | road, street, quarter |  ḥr | ḥ0.Ur ↓ ḥUr | *ḥ' i:/u:rv < Sem. *ḥur(r)v | ζηρ h' i:r |
| I.15 | Syrian |  ḥr | ḥ0.Ur ↓ ḥUr | *ḥ' u/ir(rv) < Sem. *ḥur(rv) | ζαλ h' al |
| I.21 | dust |  šḥq | šA.ḥU.qA ↓ šAḥUqA | *švh' i:/u:qv | ϣ(ζ)ι6 šəh' i:k' |
| I.25 | scorpion |  ḏnryt ₁ | ḏA.n ₁ rU.y0.ə ↓ ḏA ⁿ rUyə | *ḏv ⁿ r' i:/u:yv | σλη kil' e: |
| I.26 | arm (of oar) |  ḏnh | ḏA.n0.Uḥ ↓ ḏAnAḥ | *ḏvn' a/i/uḥ | χναζ jən' ah |

In addition, 2 words display a stressed vowel preceded by a /k/. One is written with $w = U$ in the form $c-ʒ + c-w = c0 + Uc = c.Uc$. The other is written with $w = U$ in the form $c-w + c-ʒ = cU + c0 = cU.c$. They are:

| | | | | | |
|-----|---------|--|------------------------------------|--------------|-----------------------|
| I.1 | a jar | | jA.kU.nA ↓ jAkUnA | *ʔvk'a:/o:nv | AKONE āk'o:nə |
| I.7 | chariot | | mA.ʔr0.k0.Ub.tA ↓ mArkUbt(A) | *mvrk'a/obtv | BP600YT bærk'i'owt |





§5.2 Period 2

• NON-BACK VOWELS

As for Period 2, 24 words with a stressed *non-back* vowel are attested. All of them are written without w . For 14 of them, the stressed vowel could be reconstructed either as a *non-back* /i/ or /i:/, or as a *back* /u/ or /u:/. The Egyptian spellings, however, point to a *non-back* vowel. Reliable related Semitic forms can be identified for 3 of these words, and for 2 of them they clearly support the presence of a *non-back* vowel. The Semitic evidence for the third one is problematic and not conclusive.

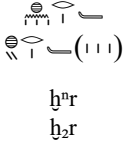
Egyptian /a/ = A > Coptic o

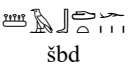
| | | | | | |
|-------|--------------|--|-----------------------------|-----------|---|
| II.2 | sea | | yA.m(A) ↓ yAm(A) | *y'am | ΕΙΟΜ j'om |
| II.6 | wagon, chart | | ʒA.gA.r0.tA ↓ ʒAgArtA | *ʒvg'altv | ΑΒΟΛΤΕ āk'i'oltə |
| II.9 | a fish | | bA.ʔr0.yA ↓ bAryA | *b'aryv | ϸ/ϸ/ΒΟΡΙ (B/B/S) ΒΑΡΕ (S) b'orə b'o:rə |
| II.20 | stronghold | | mA.k0.tA.ʔr0 ↓ mAktAr | *mvkt'ar | ΜΕΣΤΟΛ (B) mæk'it'ol |

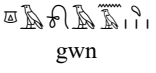
| | | | | | |
|--------|------------------------------|---|--|--|---------------------|
| II.28 | tooth, fang |  ḥ ⁿ r ḥ ₂ r | ḥA.n ₁ r0 ↓ ḥA ⁿ r | *ḥ ⁿ 'a ⁿ r *ḥ ₂ 'ar | ϣολ š'ol |
| II.34a | staff, rod (sg.) |  šbd | šA.bA.dA/d0.ə ↓ šAbAdA/də | *švb'ad | ϣβοτ (S) šəb'ot |
| II.34d | staff, rod (pl.) |  šbd | šA.bA.d0.ə ↓ šAbAdə | *švb'adyv | ϣβοτ (B) šəb'otə |
| II.41 | couch, bed |  krk | kA.rA.k(A) ↓ kArAk(A) | *kvl'ak | κιοσ kiəl'okj |
| II.42 | hair-cloth, sacking, sack |  gwn | gA.w0.nA ↓ gAwnA | *k'awnv | κοογνε ki'ownə |

Egyptian /i:/ = A > Coptic (e)

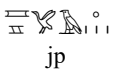
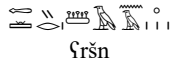
| | | | | | |
|------|--------------------------------|---|------------------------------|---------------|------------------|
| II.1 | a purple dye- plant, madder |  jp | jA.pA ↓ jApA | *ʔvp'i:(cv) | αρει əp'i: |
| II.5 | lentil |  ʕršn | ʕA.ʔr0.šA.nA ↓ ʕAršAnA | *ʕvrš'i:/u:nv | αρϣιν ərs'i:n |

Egyptian /i/,/u/ = A > Coptic α, ε, 0; Egyptian /i:/,/u:/ = A > Coptic η, (ε)

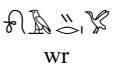
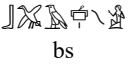
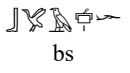
| | | | | | |
|-------|--------------------------------|---|--------------------|------------|-------------------|
| II.7 | young bird which cannot fly |  wr | wA.ʔr0 ↓ wAr | *w'i/ur | {MA2}ογαλ w'al |
| II.10 | God Bes |  bs | bA.sA ↓ bAsA | *b'i:/u:sv | βησ b'e:s |
| II.11 | pail, bucket |  bs | bA.sA ↓ bAsA | *b'i:/u:sv | βησε b'e:sə |

| | | | | | |
|-------|---------------------------|------|------------------------------|---------------------------------|------------------------------|
| II.12 | some fruit, malt | bš | bA.šA ↓ bAšA | *b'i/uʔšv > *b'i/ušʔv | βε(ε)ϣ BH(H)ϣ b'e(:)ʔš |
| II.22 | husband | hy | hA.y0 ↓ hAy | *h'i/uy | ʔA1 h'aj |
| II.31 | forecourt | ht | hA.tA ↓ hAtA | *h'i/utvj > *h'i/ujtv | ʔAεIT h'ajt |
| II.32 | lettuce, garlic | htn | hʔA.tA.nA ↓ h₂AtAnA | *h₂vt'i:u:nv < Sem. *hasi:nv | ϣ/ʔXHN (S/O) šəɟ'e:n |
| II.36 | basket | škrʕ | šA.kA.rA.ʕA ↓ šAkArAʕA | *švk'i:u:rvʕv | ϣK1A šək'i:l |
| II.37 | ashes, cinders, embers | qrmt | qA.yr0.mA.tA ↓ qArmAtA | *k'i/urmv(t) < Sem. — | K(ε)PME k'ermə |
| II.38 | burnt-offering | qrr | qA.rA.rA ↓ qArArA | *qvr'i:u:rv | ʕ1A k'əl'i:l |
| II.39 | precious stone | qrt | qA.r0.tA ↓ qArtA | *q'i/ultv | ʕ1TE k'eltə |
| II.44 | heap, hillock | tʔr | tA.n1r(ə) ↓ tAʔr(ə) | *t'i/uʔr(rv) < Sem. *til(lv) | TΔA t'al |
| II.47 | self-bent rods | dʔr | dA.n1r0 ↓ dAʔr | *d'i/uʔr | XΔA (B) dʕ'al |

• BACK VOWELS

There are 26 words that display or may display a *back* vowel. In 19 of them, the stressed vowel could be reconstructed both as *non-back* or *back*, but the Egyptian spelling clearly point to a *back* vowel. Related Semitic forms are attested for 7 of them, and they all support the presence of a *back* vowel (§6). All of these 26 words are written with *w = U*.

7 of them according to the form $c-w + c = cU + c = cU.c$.

9 according to the form $c + c-w = c + Uc = c.Uc$.

4 according to the form $c-w + c-w = cU + Uc = cUc$.

3 both according to the form $c-w + c = cU + c = cU.c$ and $c + c-w = c + Uc = c.Uc$ or with a cluster $r+c$, in the form $c + \text{ʿ}r + c-w = Urc = c.Urc$.

2 in both the forms $c-w + c = cU + c = cU.c$ and $c-w + c-w = cU + Uc = cUc$.



In 1 case, $w = U$ follows a cluster $r+c$, in the form $c + \text{ʿ}r + c-w = Urc = c.Urc$.

Egyptian /a:/ > /o:/ = U > Coptic ω, ογ

| | | |
|------|------------------------|---|
| II.4 | stones, rocks, pebbles |  𓆎𓆏𓆐𓆑𓆒𓆓𓆔𓆕𓆖𓆗𓆘𓆙𓆚𓆛𓆜𓆝𓆞𓆟𓆠𓆡𓆢𓆣𓆤𓆥𓆦𓆧𓆨𓆩𓆪𓆫𓆬𓆭𓆮𓆯𓆰𓆱𓆲𓆳𓆴𓆵𓆶𓆷𓆸𓆹𓆺𓆻𓆼𓆽𓆾𓆿𓇀𓇁𓇂𓇃𓇄𓇅𓇆𓇇𓇈𓇉𓇊𓇋𓇌𓇍𓇎𓇏𓇐𓇑𓇒𓇓𓇔𓇕𓇖𓇗𓇘𓇙𓇚𓇛𓇜𓇝𓇞𓇟𓇠𓇡𓇢𓇣𓇤𓇥𓇦𓇧𓇨𓇩𓇪𓇫𓇬𓇭𓇮𓇯𓇰𓇱𓇲𓇳𓇴𓇵𓇶𓇷𓇸𓇹𓇺𓇻𓇼𓇽𓇾𓇿𓈀𓈁𓈂𓈃𓈄𓈅𓈆𓈇𓈈𓈉𓈊𓈋𓈌𓈍𓈎𓈏𓈐𓈑𓈒𓈓𓈔𓈕𓈖𓈗𓈘𓈙𓈚𓈛𓈜𓈝𓈞𓈟𓈠𓈡𓈢𓈣𓈤𓈥𓈦𓈧𓈨𓈩𓈪𓈫𓈬𓈭𓈮𓈯𓈰𓈱𓈲𓈳𓈴𓈵𓈶𓈷𓈸𓈹𓈺𓈻𓈼𓈽𓈾𓈿𓉀𓉁𓉂𓉃𓉄𓉅𓉆𓉇𓉈𓉉𓉊𓉋𓉌𓉍𓉎𓉏𓉐𓉑𓉒𓉓𓉔𓉕𓉖𓉗𓉘𓉙𓉚𓉛𓉜𓉝𓉞𓉟𓉠𓉡𓉢𓉣𓉤𓉥𓉦𓉧𓉨𓉩𓉪𓉫𓉬𓉭𓉮𓉯𓉰𓉱𓉲𓉳𓉴𓉵𓉶𓉷𓉸𓉹𓉺𓉻𓉼𓉽𓉾𓉿𓊀𓊁𓊂𓊃𓊄𓊅𓊆𓊇𓊈𓊉𓊊𓊋𓊌𓊍𓊎𓊏𓊐𓊑𓊒𓊓𓊔𓊕𓊖𓊗𓊘𓊙𓊚𓊛𓊜𓊝𓊞𓊟𓊠𓊡𓊢𓊣𓊤𓊥𓊦𓊧𓊨𓊩𓊪𓊫𓊬𓊭𓊮𓊯𓊰𓊱𓊲𓊳𓊴𓊵𓊶𓊷𓊸𓊹𓊺𓊻𓊼𓊽𓊾𓊿𓋀𓋁𓋂𓋃𓋄𓋅𓋆𓋇𓋈𓋉𓋊𓋋𓋌𓋍𓋎𓋏𓋐𓋑𓋒𓋓𓋔𓋕𓋖𓋗𓋘𓋙𓋚𓋛𓋜𓋝𓋞𓋟𓋠𓋡𓋢𓋣𓋤𓋥𓋦𓋧𓋨𓋩𓋪𓋫𓋬𓋭𓋮𓋯𓋰𓋱𓋲𓋳𓋴𓋵𓋶𓋷𓋸𓋹𓋺𓋻𓋼𓋽𓋾𓋿𓌀𓌁𓌂𓌃𓌄𓌅𓌆𓌇𓌈𓌉𓌊𓌋𓌌𓌍𓌎𓌏𓌐𓌑𓌒𓌓𓌔𓌕𓌖𓌗𓌘𓌙𓌚𓌛𓌜𓌝𓌞𓌟𓌠𓌡𓌢𓌣𓌤𓌥𓌦𓌧𓌨𓌩𓌪𓌫𓌬𓌭𓌮𓌯𓌰𓌱𓌲𓌳𓌴𓌵𓌶𓌷𓌸𓌹𓌺𓌻𓌼𓌽𓌾𓌿𓍀𓍁𓍂𓍃𓍄𓍅𓍆𓍇𓍈𓍉𓍊𓍋𓍌𓍍𓍎𓍏𓍐𓍑𓍒𓍓𓍔𓍕𓍖𓍗𓍘𓍙𓍚𓍛𓍜𓍝𓍞𓍟𓍠𓍡𓍢𓍣𓍤𓍥𓍦𓍧𓍨𓍩𓍪𓍫𓍬𓍭𓍮𓍯𓍰𓍱𓍲𓍳𓍴𓍵𓍶𓍷𓍸𓍹𓍺𓍻𓍼𓍽𓍾𓍿𓎀𓎁𓎂𓎃𓎄𓎅𓎆𓎇𓎈𓎉𓎊𓎋𓎌𓎍𓎎𓎏𓎐𓎑𓎒𓎓𓎔𓎕𓎖𓎗𓎘𓎙𓎚𓎛𓎜𓎝𓎞𓎟𓎠𓎡𓎢𓎣𓎤𓎥𓎦𓎧𓎨𓎩𓎪𓎫𓎬𓎭𓎮𓎯𓎰𓎱𓎲𓎳𓎴𓎵𓎶𓎷𓎸𓎹𓎺𓎻𓎼𓎽𓎾𓎿𓏀𓏁𓏂𓏃𓏄𓏅𓏆𓏇𓏈𓏉𓏊𓏋𓏌𓏍𓏎𓏏𓏐𓏑𓏒𓏓𓏔𓏕𓏖𓏗𓏘𓏙𓏚𓏛𓏜𓏝𓏞𓏟𓏠𓏡𓏢𓏣𓏤𓏥𓏦𓏧𓏨𓏩𓏪𓏫𓏬𓏭𓏮𓏯𓏰𓏱𓏲𓏳𓏴𓏵𓏶𓏷𓏸𓏹𓏺𓏻𓏼𓏽𓏾𓏿𓐀𓐁𓐂𓐃𓐄𓐅𓐆𓐇𓐈𓐉𓐊𓐋𓐌𓐍𓐎𓐏𓐐𓐑𓐒𓐓𓐔𓐕𓐖𓐗𓐘𓐙𓐚𓐛𓐜𓐝𓐞𓐟𓐠𓐡𓐢𓐣𓐤𓐥𓐦𓐧𓐨𓐩𓐪𓐫𓐬𓐭𓐮𓐯𓐰𓐱𓐲𓐳𓐴𓐵𓐶𓐷𓐸𓐹𓐺𓐻𓐼𓐽𓐾𓐿𓑀𓑁𓑂𓑃𓑄𓑅𓑆𓑇𓑈𓑉𓑊𓑋𓑌𓑍𓑎𓑏𓑐𓑑𓑒𓑓𓑔𓑕𓑖𓑗𓑘𓑙𓑚𓑛𓑜𓑝𓑞𓑟𓑠𓑡𓑢𓑣𓑤𓑥𓑦𓑧𓑨𓑩𓑪𓑫𓑬𓑭𓑮𓑯𓑰𓑱𓑲𓑳𓑴𓑵𓑶𓑷𓑸𓑹𓑺𓑻𓑼𓑽𓑾𓑿𓒀𓒁𓒂𓒃𓒄𓒅𓒆𓒇𓒈𓒉𓒊𓒋𓒌𓒍𓒎𓒏𓒐𓒑𓒒𓒓𓒔𓒕𓒖𓒗𓒘𓒙𓒚𓒛𓒜𓒝𓒞𓒟𓒠𓒡𓒢𓒣𓒤𓒥𓒦𓒧𓒨𓒩𓒪𓒫𓒬𓒭𓒮𓒯𓒰𓒱𓒲𓒳𓒴𓒵𓒶𓒷𓒸𓒹𓒺𓒻𓒼𓒽𓒾𓒿𓓀𓓁𓓂𓓃𓓄𓓅𓓆𓓇𓓈𓓉𓓊𓓋𓓌𓓍𓓎𓓏𓓐𓓑𓓒𓓓𓓔𓓕𓓖𓓗𓓘𓓙𓓚𓓛𓓜𓓝𓓞𓓟𓓠𓓡𓓢𓓣𓓤𓓥𓓦𓓧𓓨𓓩𓓪𓓫𓓬𓓭𓓮𓓯𓓰𓓱𓓲𓓳𓓴𓓵𓓶𓓷𓓸𓓹𓓺𓓻𓓼𓓽𓓾𓓿𓔀𓔁𓔂𓔃𓔄𓔅𓔆𓔇𓔈𓔉𓔊𓔋𓔌𓔍𓔎𓔏𓔐𓔑𓔒𓔓𓔔𓔕𓔖𓔗𓔘𓔙𓔚𓔛𓔜𓔝𓔞𓔟𓔠𓔡𓔢𓔣𓔤𓔥𓔦𓔧𓔨𓔩𓔪𓔫𓔬𓔭𓔮𓔯𓔰𓔱𓔲𓔳𓔴𓔵𓔶𓔷𓔸𓔹𓔺𓔻𓔼𓔽𓔾𓔿𓕀𓕁𓕂𓕃𓕄𓕅𓕆𓕇𓕈𓕉𓕊𓕋𓕌𓕍𓕎𓕏𓕐𓕑𓕒𓕓𓕔𓕕𓕖𓕗𓕘𓕙𓕚𓕛𓕜𓕝𓕞𓕟𓕠𓕡𓕢𓕣𓕤𓕥𓕦𓕧𓕨𓕩𓕪𓕫𓕬𓕭𓕮𓕯𓕰𓕱𓕲𓕳𓕴𓕵𓕶𓕷𓕸𓕹𓕺𓕻𓕼𓕽𓕾𓕿𓖀𓖁𓖂𓖃𓖄𓖅𓖆𓖇𓖈𓖉𓖊𓖋𓖌𓖍𓖎𓖏𓖐𓖑𓖒𓖓𓖔𓖕𓖖𓖗𓖘𓖙𓖚𓖛𓖜𓖝𓖞𓖟𓖠𓖡𓖢𓖣𓖤𓖥𓖦𓖧𓖨𓖩𓖪𓖫𓖬𓖭𓖮𓖯𓖰𓖱𓖲𓖳𓖴𓖵𓖶𓖷𓖸𓖹𓖺𓖻𓖼𓖽𓖾𓖿𓗀𓗁𓗂𓗃𓗄𓗅𓗆𓗇𓗈𓗉𓗊𓗋𓗌𓗍𓗎𓗏𓗐𓗑𓗒𓗓𓗔𓗕𓗖𓗗𓗘𓗙𓗚𓗛𓗜𓗝𓗞𓗟𓗠𓗡𓗢𓗣𓗤𓗥𓗦𓗧𓗨𓗩𓗪𓗫𓗬𓗭𓗮𓗯𓗰𓗱𓗲𓗳𓗴𓗵𓗶𓗷𓗸𓗹𓗺𓗻𓗼𓗽𓗾𓗿𓘀𓘁𓘂𓘃𓘄𓘅𓘆𓘇𓘈𓘉𓘊𓘋𓘌𓘍𓘎𓘏𓘐𓘑𓘒𓘓𓘔𓘕𓘖𓘗𓘘𓘙𓘚𓘛𓘜𓘝𓘞𓘟𓘠𓘡𓘢𓘣𓘤𓘥𓘦𓘧𓘨𓘩𓘪𓘫𓘬𓘭𓘮𓘯𓘰𓘱𓘲𓘳𓘴𓘵𓘶𓘷𓘸𓘹𓘺𓘻𓘼𓘽𓘾𓘿𓙀𓙁𓙂𓙃𓙄𓙅𓙆𓙇𓙈𓙉𓙊𓙋𓙌𓙍𓙎𓙏𓙐𓙑𓙒𓙓𓙔𓙕𓙖𓙗𓙘𓙙𓙚𓙛𓙜𓙝𓙞𓙟𓙠𓙡𓙢𓙣𓙤𓙥𓙦𓙧𓙨𓙩𓙪𓙫𓙬𓙭𓙮𓙯𓙰𓙱𓙲𓙳𓙴𓙵𓙶𓙷𓙸𓙹𓙺𓙻𓙼𓙽𓙾𓙿𓚀𓚁𓚂𓚃𓚄𓚅𓚆𓚇𓚈𓚉𓚊𓚋𓚌𓚍𓚎𓚏𓚐𓚑𓚒𓚓𓚔𓚕𓚖𓚗𓚘𓚙𓚚𓚛𓚜𓚝𓚞𓚟𓚠𓚡𓚢𓚣𓚤𓚥𓚦𓚧𓚨𓚩𓚪𓚫𓚬𓚭𓚮𓚯𓚰𓚱𓚲𓚳𓚴𓚵𓚶𓚷𓚸𓚹𓚺𓚻𓚼𓚽𓚾𓚿𓛀𓛁𓛂𓛃𓛄𓛅𓛆𓛇𓛈𓛉𓛊𓛋𓛌𓛍𓛎𓛏𓛐𓛑𓛒𓛓𓛔𓛕𓛖𓛗𓛘𓛙𓛚𓛛𓛜𓛝𓛞𓛟𓛠𓛡𓛢𓛣𓛤𓛥𓛦𓛧𓛨𓛩𓛪𓛫𓛬𓛭𓛮𓛯𓛰𓛱𓛲𓛳𓛴𓛵𓛶𓛷𓛸𓛹𓛺𓛻𓛼𓛽𓛾𓛿𓜀𓜁𓜂𓜃𓜄𓜅𓜆𓜇𓜈𓜉𓜊𓜋𓜌𓜍𓜎𓜏𓜐𓜑𓜒𓜓𓜔𓜕𓜖𓜗𓜘𓜙𓜚𓜛𓜜𓜝𓜞𓜟𓜠𓜡𓜢𓜣𓜤𓜥𓜦𓜧𓜨𓜩𓜪𓜫𓜬𓜭𓜮𓜯𓜰𓜱𓜲𓜳𓜴𓜵𓜶𓜷𓜸𓜹𓜺𓜻𓜼𓜽𓜾𓜿𓝀𓝁𓝂𓝃𓝄𓝅𓝆𓝇𓝈𓝉𓝊𓝋𓝌𓝍𓝎𓝏𓝐𓝑𓝒𓝓𓝔𓝕𓝖𓝗𓝘𓝙𓝚𓝛𓝜𓝝𓝞𓝟𓝠𓝡𓝢𓝣𓝤𓝥𓝦𓝧𓝨𓝩𓝪𓝫𓝬𓝭𓝮𓝯𓝰𓝱𓝲𓝳𓝴𓝵𓝶𓝷𓝸𓝹𓝺𓝻𓝼𓝽𓝾𓝿𓞀𓞁𓞂𓞃𓞄𓞅𓞆𓞇𓞈𓞉𓞊𓞋𓞌𓞍𓞎𓞏𓞐𓞑𓞒𓞓𓞔𓞕𓞖𓞗𓞘𓞙𓞚𓞛𓞜𓞝𓞞𓞟𓞠𓞡𓞢𓞣𓞤𓞥𓞦𓞧𓞨𓞩𓞪𓞫𓞬𓞭𓞮𓞯𓞰𓞱𓞲𓞳𓞴𓞵𓞶𓞷𓞸𓞹𓞺𓞻𓞼𓞽𓞾𓞿𓟀𓟁𓟂𓟃𓟄𓟅𓟆𓟇𓟈𓟉𓟊𓟋𓟌𓟍𓟎𓟏𓟐𓟑𓟒𓟓𓟔𓟕𓟖𓟗𓟘𓟙𓟚𓟛𓟜𓟝𓟞𓟟𓟠𓟡𓟢𓟣𓟤𓟥𓟦𓟧𓟨𓟩𓟪𓟫𓟬𓟭𓟮𓟯𓟰𓟱𓟲𓟳𓟴𓟵𓟶𓟷𓟸𓟹𓟺𓟻𓟼𓟽𓟾𓟿𓠀𓠁𓠂𓠃𓠄𓠅𓠆𓠇𓠈𓠉𓠊𓠋𓠌𓠍𓠎𓠏𓠐𓠑𓠒𓠓𓠔𓠕𓠖𓠗𓠘𓠙𓠚𓠛𓠜𓠝𓠞𓠟𓠠𓠡𓠢𓠣𓠤𓠥𓠦𓠧𓠨𓠩𓠪𓠫𓠬𓠭𓠮𓠯𓠰𓠱𓠲𓠳𓠴𓠵𓠶𓠷𓠸𓠹𓠺𓠻𓠼𓠽𓠾𓠿𓡀𓡁𓡂𓡃𓡄𓡅𓡆𓡇𓡈𓡉𓡊𓡋𓡌𓡍𓡎𓡏𓡐𓡑𓡒𓡓𓡔𓡕𓡖𓡗𓡘𓡙𓡚𓡛𓡜𓡝𓡞𓡟𓡠𓡡𓡢𓡣𓡤𓡥𓡦𓡧𓡨𓡩𓡪𓡫𓡬𓡭𓡮𓡯𓡰𓡱𓡲𓡳𓡴𓡵𓡶𓡷𓡸𓡹𓡺𓡻𓡼𓡽𓡾𓡿𓢀𓢁𓢂𓢃𓢄𓢅𓢆𓢇𓢈𓢉𓢊𓢋𓢌𓢍𓢎𓢏𓢐𓢑𓢒𓢓𓢔𓢕𓢖𓢗𓢘𓢙𓢚𓢛𓢜𓢝𓢞𓢟𓢠𓢡𓢢𓢣𓢤𓢥𓢦𓢧𓢨𓢩𓢪𓢫𓢬𓢭𓢮𓢯𓢰𓢱𓢲𓢳𓢴𓢵𓢶𓢷𓢸𓢹𓢺𓢻𓢼𓢽𓢾𓢿𓣀𓣁𓣂𓣃𓣄𓣅𓣆𓣇𓣈𓣉𓣊𓣋𓣌𓣍𓣎𓣏𓣐𓣑𓣒𓣓𓣔𓣕𓣖𓣗𓣘𓣙𓣚𓣛𓣜𓣝𓣞𓣟𓣠𓣡𓣢𓣣𓣤𓣥𓣦𓣧𓣨𓣩𓣪𓣫𓣬𓣭𓣮𓣯𓣰𓣱𓣲𓣳𓣴𓣵𓣶𓣷𓣸𓣹𓣺𓣻𓣼𓣽𓣾𓣿𓤀𓤁𓤂𓤃𓤄𓤅𓤆𓤇𓤈𓤉𓤊𓤋𓤌𓤍𓤎𓤏𓤐𓤑𓤒𓤓𓤔𓤕𓤖𓤗𓤘𓤙𓤚𓤛𓤜𓤝𓤞𓤟𓤠𓤡𓤢𓤣𓤤𓤥𓤦𓤧𓤨𓤩𓤪𓤫𓤬𓤭𓤮𓤯𓤰𓤱𓤲𓤳𓤴𓤵𓤶𓤷𓤸𓤹𓤺𓤻𓤼𓤽𓤾𓤿𓥀𓥁𓥂𓥃𓥄𓥅𓥆𓥇𓥈𓥉𓥊𓥋𓥌𓥍𓥎𓥏𓥐𓥑𓥒𓥓𓥔𓥕𓥖𓥗𓥘𓥙𓥚𓥛𓥜𓥝𓥞𓥟𓥠𓥡𓥢𓥣𓥤𓥥𓥦𓥧𓥨𓥩𓥪𓥫𓥬𓥭𓥮𓥯𓥰𓥱𓥲𓥳𓥴𓥵𓥶𓥷𓥸𓥹𓥺𓥻𓥼𓥽𓥾𓥿𓦀𓦁𓦂𓦃𓦄𓦅𓦆𓦇𓦈𓦉𓦊𓦋𓦌𓦍𓦎𓦏𓦐𓦑𓦒𓦓𓦔𓦕𓦖𓦗𓦘𓦙𓦚𓦛𓦜𓦝𓦞𓦟𓦠𓦡𓦢𓦣𓦤𓦥𓦦𓦧𓦨𓦩𓦪𓦫𓦬𓦭𓦮𓦯𓦰𓦱𓦲𓦳𓦴𓦵𓦶𓦷𓦸𓦹𓦺𓦻𓦼𓦽𓦾𓦿𓧀𓧁𓧂𓧃𓧄𓧅𓧆𓧇𓧈𓧉𓧊𓧋𓧌𓧍𓧎𓧏𓧐𓧑𓧒𓧓𓧔𓧕𓧖𓧗𓧘𓧙𓧚𓧛𓧜𓧝𓧞𓧟𓧠𓧡𓧢𓧣𓧤𓧥𓧦𓧧𓧨𓧩𓧪𓧫𓧬𓧭𓧮𓧯𓧰𓧱𓧲𓧳𓧴𓧵𓧶𓧷𓧸𓧹𓧺𓧻𓧼𓧽𓧾𓧿𓨀𓨁𓨂𓨃𓨄𓨅𓨆𓨇𓨈𓨉𓨊𓨋𓨌𓨍𓨎𓨏𓨐𓨑𓨒𓨓𓨔𓨕𓨖𓨗𓨘𓨙𓨚𓨛𓨜𓨝𓨞𓨟𓨠𓨡𓨢𓨣𓨤𓨥𓨦𓨧𓨨𓨩𓨪𓨫𓨬𓨭𓨮𓨯𓨰𓨱𓨲𓨳𓨴𓨵𓨶𓨷𓨸𓨹𓨺𓨻𓨼𓨽𓨾𓨿𓩀𓩁𓩂𓩃𓩄𓩅𓩆𓩇𓩈𓩉𓩊𓩋𓩌𓩍𓩎𓩏𓩐𓩑𓩒𓩓𓩔𓩕𓩖𓩗𓩘𓩙𓩚𓩛𓩜𓩝𓩞𓩟𓩠𓩡𓩢𓩣𓩤𓩥𓩦𓩧𓩨𓩩𓩪𓩫𓩬𓩭𓩮𓩯𓩰𓩱𓩲𓩳𓩴𓩵𓩶𓩷𓩸𓩹𓩺𓩻𓩼𓩽𓩾𓩿𓪀𓪁𓪂𓪃𓪄𓪅𓪆𓪇𓪈𓪉𓪊𓪋𓪌𓪍𓪎𓪏𓪐𓪑𓪒𓪓𓪔𓪕𓪖𓪗𓪘𓪙𓪚𓪛𓪜𓪝𓪞𓪟𓪠𓪡𓪢𓪣𓪤𓪥𓪦𓪧𓪨𓪩𓪪𓪫𓪬𓪭𓪮𓪯𓪰𓪱𓪲𓪳𓪴𓪵𓪶𓪷𓪸𓪹𓪺𓪻𓪼𓪽𓪾𓪿𓫀𓫁𓫂𓫃𓫄𓫅𓫆𓫇𓫈𓫉𓫊𓫋𓫌𓫍𓫎𓫏𓫐𓫑𓫒𓫓𓫔𓫕𓫖𓫗𓫘𓫙𓫚𓫛𓫜𓫝𓫞𓫟𓫠𓫡𓫢𓫣𓫤𓫥𓫦𓫧𓫨𓫩𓫪𓫫𓫬𓫭𓫮𓫯𓫰𓫱𓫲𓫳𓫴𓫵𓫶𓫷𓫸𓫹𓫺𓫻𓫼𓫽𓫾𓫿𓬀𓬁𓬂𓬃𓬄𓬅𓬆𓬇𓬈𓬉𓬊𓬋𓬌𓬍𓬎𓬏𓬐𓬑𓬒𓬓𓬔𓬕𓬖𓬗𓬘𓬙𓬚𓬛𓬜𓬝𓬞𓬟𓬠𓬡𓬢𓬣𓬤𓬥𓬦𓬧𓬨𓬩𓬪𓬫𓬬𓬭𓬮𓬯𓬰𓬱𓬲𓬳𓬴𓬵𓬶𓬷𓬸𓬹𓬺𓬻𓬼𓬽𓬾𓬿𓭀𓭁𓭂𓭃𓭄𓭅𓭆𓭇𓭈𓭉𓭊𓭋𓭌𓭍𓭎𓭏𓭐𓭑𓭒𓭓𓭔𓭕𓭖𓭗𓭘𓭙𓭚𓭛𓭜𓭝𓭞𓭟𓭠𓭡𓭢𓭣𓭤𓭥𓭦𓭧𓭨𓭩𓭪𓭫𓭬𓭭𓭮𓭯𓭰𓭱𓭲𓭳𓭴𓭵𓭶𓭷𓭸𓭹𓭺𓭻𓭼𓭽𓭾𓭿𓮀𓮁𓮂𓮃𓮄𓮅𓮆𓮇𓮈𓮉𓮊𓮋𓮌𓮍𓮎𓮏𓮐𓮑𓮒𓮓𓮔𓮕𓮖𓮗𓮘𓮙𓮚𓮛𓮜𓮝𓮞𓮟𓮠𓮡𓮢𓮣𓮤𓮥𓮦𓮧𓮨𓮩𓮪𓮫𓮬𓮭𓮮𓮯𓮰𓮱𓮲𓮳𓮴𓮵𓮶𓮷𓮸𓮹𓮺𓮻𓮼𓮽𓮾𓮿𓯀𓯁𓯂𓯃𓯄𓯅𓯆𓯇𓯈𓯉𓯊𓯋𓯌𓯍𓯎𓯏𓯐𓯑𓯒𓯓𓯔𓯕𓯖𓯗𓯘𓯙𓯚𓯛𓯜𓯝𓯞𓯟𓯠𓯡𓯢𓯣𓯤𓯥𓯦𓯧𓯨𓯩𓯪𓯫𓯬𓯭𓯮𓯯𓯰𓯱𓯲𓯳𓯴𓯵𓯶𓯷𓯸𓯹𓯺𓯻𓯼𓯽𓯾𓯿𓰀𓰁𓰂𓰃𓰄𓰅𓰆𓰇𓰈𓰉𓰊𓰋𓰌𓰍𓰎𓰏𓰐𓰑𓰒𓰓𓰔𓰕𓰖𓰗𓰘𓰙𓰚𓰛𓰜𓰝𓰞𓰟𓰠𓰡𓰢𓰣𓰤𓰥𓰦𓰧𓰨𓰩𓰪𓰫𓰬𓰭𓰮𓰯𓰰𓰱𓰲𓰳𓰴𓰵𓰶𓰷𓰸𓰹𓰺𓰻𓰼𓰽𓰾𓰿𓱀𓱁𓱂𓱃𓱄𓱅𓱆𓱇𓱈𓱉𓱊𓱋𓱌𓱍𓱎𓱏𓱐𓱑𓱒𓱓𓱔𓱕𓱖𓱗𓱘𓱙𓱚𓱛𓱜𓱝𓱞𓱟𓱠𓱡𓱢𓱣𓱤𓱥𓱦𓱧𓱨𓱩𓱪𓱫𓱬𓱭𓱮𓱯𓱰𓱱𓱲𓱳𓱴𓱵𓱶𓱷𓱸𓱹𓱺𓱻𓱼𓱽𓱾𓱿𓲀𓲁𓲂𓲃𓲄𓲅𓲆𓲇𓲈𓲉𓲊𓲋𓲌𓲍𓲎𓲏𓲐𓲑𓲒𓲓𓲔𓲕𓲖𓲗𓲘𓲙𓲚𓲛𓲜𓲝𓲞𓲟𓲠𓲡𓲢𓲣𓲤𓲥𓲦𓲧𓲨𓲩𓲪𓲫𓲬𓲭𓲮𓲯𓲰𓲱𓲲𓲳𓲴𓲵𓲶𓲷𓲸𓲹𓲺𓲻𓲼𓲽𓲾𓲿𓳀𓳁𓳂𓳃𓳄𓳅𓳆𓳇𓳈𓳉𓳊𓳋𓳌𓳍𓳎𓳏𓳐𓳑𓳒𓳓𓳔𓳕𓳖𓳗𓳘𓳙𓳚𓳛𓳜𓳝𓳞𓳟𓳠𓳡𓳢𓳣𓳤𓳥𓳦𓳧𓳨𓳩𓳪𓳫𓳬𓳭𓳮𓳯𓳰𓳱𓳲𓳳 |
|------|------------------------|---|

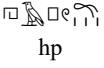
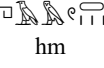
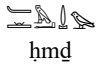
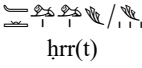
Egyptian /i/,/u/ = U > Coptic α , ϵ ; Egyptian /i:/,/u:/ = U > Coptic η , (ϵ)

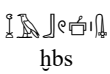
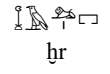
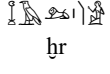
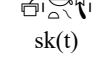
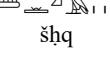
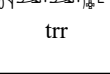
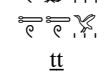
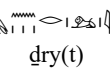
| | | | | | |
|-------|----------------|---|--|--|---|
| II.3 | pebble | | $\zeta 0.U n_1/3(r)r$ $\zeta U.n_1/3r0$ ↓ $\zeta U^n r$ | * $\zeta' i/ur$ | $\alpha\lambda$ 'al |
| II.8 | ball of eyes | | $bU.n_1r0$ ↓ $bU^n r$ | * $b' i/u^n r$ | $\beta\alpha\lambda$ b'al |
| II.13 | bean | | $pU.rA(.yA)$ ↓ $pUr(yA)$ | * $p' i/ur(yv)$ < Sem. * $pu:l$ | $\phi\epsilon\lambda$ (B) $p^h' el$ |
| II.14 | spear, javelin | | $m0.U^3rh$ ↓ mUr^h | * $m' i/ur^h v$ < Sem. * $mur^h v$ | $\mu\epsilon p(\epsilon)\zeta$ $\mu\epsilon p\epsilon/h\zeta$ $m' er^h$ $m\acute{a}r' e:h$ |
| II.16 | basket, box | | $mA.h^30.Ur$ ↓ mAh_2Ur | * $mvh_2' i:/u:rv$ | $\mu\alpha\psi\mu$ $m\acute{a}\delta' i:r$ |
| II.17 | 6th month | | $mA.h0.Ur$ ↓ mAh_1Ur | * $mvh' i:/u:rv$ | $\mu\alpha\psi\mu$ $m\acute{a}\delta' i:r$ |
| II.23 | law(s) |  | $h0.Up$ ↓ hUp | * $h' i/up$ | $\zeta\alpha\pi$ h'ap |
| II.24 | fare |  | $h0.Um$ ↓ $hUm(A)$ | * $h' i:/u:mv$ | $\zeta\eta\mu\epsilon$ h'e:m\acute{a} |
| II.25 | vinegar |  | $hU.m(A).d(A)$ ↓ $hUm(A)d(A)$ | * $h' i:/$ $u:mv\acute{d}(v)$ * $h' i/um\acute{d}v$ < Sem. * $hum\acute{s}v$ | $\zeta\eta\mu\alpha$ $\zeta\mu\alpha$ $h' e(:)m\acute{d}\zeta$ |
| II.26 | flower |  | $hU.rU.Ur$ ↓ $hUrUr$ | * $hvr' i:/u:rv$ | $\zeta\eta\mu\epsilon$ hr'e:r\acute{a} |

| | | | | | |
|-------|--------------------------|---|---|---|------------------------|
| II.27 | lamp |  hbs | h0.Ub.sA ↓ hUb(A)sA | *h'i:/u:bvsv | ʒ/ʒHBC (S/B) h'e:bs |
| II.29 | road, street, quarter |  hr | h0.Ur ↓ hUr | *h'i:/u:rv < Sem. *hur(r)v | ʒP h'i:r |
| II.30 | Syrian |  hr | h0.Ur ↓ hUr | *h'u/ir(rv) < Sem. *hur(rv) | ʒΔλ h'al |
| II.33 | ass's foal |  sk(t) | s0.Uk(ə) ↓ sUk(ə) | *s'i:/u:kv | CH6 s'e:kj |
| II.35 | dust |  šhq | šA.hU.qA ↓ šAḫUqA | *šv'h'i:/u:qv | ʒ(ʒ)16 šəh'i:kj |
| II.45 | oven |  trr | tA.rU.Ur ↓ tArUr | *tvr'i:/u:r(v) < Sem. *tv(n) nu:r(v) | TPP tər'i:r |
| II.46 | sparrow |  tt | tU.t0 ↓ tU.Ut ↓ tUt | *t'i/ut | ʒAX dʒ'adʒ |
| II.48 | scorpion |  dry(t) | dA.n.r0.rU.yA ↓ dA ⁿ (r)rUyA | *dvr'i:/u:yv | 6AH k'il'e: |
| II.49 | jar, bowl |  dhrt | dA.hU.yr0.tA ↓ dAḫUrtA | *dvh'i/urtv > *dvr'i/uḫtv < Sem. *švluhit / *švllōhtv | χλA2TC dʒəl'ahtəs |

Moreover, 2 words display a stressed vowel preceded by a /k/. Both are written with *w* in the form *c-ʒ + c-w = c0 + Uc = c.Uc*. They are:

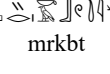
| | | | | | |
|-------|---------|--|------------------------------------|--------------|----------------------|
| II.15 | chariot |  mrkbt | mA.yr0.k0.Ub.tA ↓ mArkUbt(A) | *mvrk'a/obtv | BP600YT bərki'owt |
|-------|---------|--|------------------------------------|--------------|----------------------|

| | | | | | |
|-------|----------------|--------|-------------------|---------|---------------|
| II.40 | (palm of) hand | kp | k0.Up ↓ kUp | *k'a/op | ⲥⲟⲡ k'i'op |
|-------|----------------|--------|-------------------|---------|---------------|

§5.3 Period 3

• NON-BACK VOWELS





Only 21 words from Period 3 are attested in the corpus. 10 display a stressed *non-back* vowel, and they are all written without *w*. In 5 of them, the stressed vowel could be reconstructed either as /i:/ or as /u:/. The Egyptian spelling, however, points to a *non-back* vowel. Related Semitic forms can be reliably identified for 3 of them. The evidence they provide clearly support the presence of a *non-back* vowel.

Egyptian /i:/, /u:/ > /e/ = A > Coptic ⲁ, ⲉ, Ⲑ

| | | | | | |
|--------|---------------------------|----------------------|---|-------------------------|---------------------------------------|
| III.3 | stones, rocks, pebbles | ʕ ⁿ r | ʕA.n ₁ ʔr0 ↓ ʕA ⁿ r | *ʕ'e ⁿ r | ⲁⲗ 'al |
| III.6 | some fruit, malt | bš | bA.šA ↓ bAšA | *b'ešʔv > *b'eʔšv | βε(ε)c (S/B) βH(Η)ϣ (S/B) b'eʔš |
| III.8 | back of head | mkḥ | mAk.hA ↓ mAkḥA | *m'ekḥv | ⲙⲁⲕⲔ m'akh |
| III.10 | husband | hy | hA.y0 ↓ hAy | *h'ey | ⲕⲁⲓ h'aj |
| III.22 | sparrow | tt | tA.tA ↓ tAtA | *t'et | ⲕⲁⲕ dʒ'adʒ |

Egyptian /i:/, /u:/ = A > Coptic Ⲏ, ⲓ

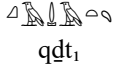
| | | | | | |
|-------|--------|----------|------------------------------|---------------|------------------|
| III.4 | lentil | ʕršn | ʕA.ʔr0.šA.nA ↓ ʕAršAnA | *ʕvrš'i:/u:nv | ⲁⲣϣⲓⲛ ārš'i:n |
|-------|--------|----------|------------------------------|---------------|------------------|

| | | | | | |
|--------|--------------------------------------|---|---------------------------|-----------------------------------|--------------------|
| III.13 | commerce, associate, companion |  | hA.bA.(y)r0 ↓ hAbAr | *hvb'i:/u:r < Sem. *hab'er | ϣβηρ hvb'i:/u:r |
| III.18 | burnt-offering |  | qA.rA.rA ↓ qArArA | *qvr'i:/u:rv | ϭιλλ k'əl'i:i |
| III.19 | back of hand |  | qA.d0.ə ↓ qAdə | *q'i:/u:dv | ϭιχ k'i:i:dʒ |
| III.23 | shrine, naos, inner sanctuary |  | dA.bA.yr0 ↓ dAbAr | *dvb'i:/u:r < Sem. *dab'i:r | ταβιρ täb'i:r |

• BACK VOWELS



A stressed *back* vowel characterises instead 11 words, which are all written with *w* = *U*. The stressed vowel of 3 of them could be reconstructed either as /i:/ or as /u:/. The Egyptian spellings suggest a *back* vowel, and the Semitic evidence, available for both of them, supports this interpretation.

5 are spelled according to the form *c-w* + *c* = *cU* + *c* = *cU.c*, while 4 according to the form *c-w* = *c* + *Uc* = *c.Uc*.

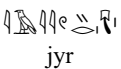
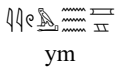
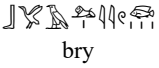

2 are spelled according to the form *c-w* + *c-w* = *cU* + *Uc* = *cUc*.

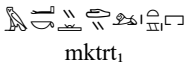
Egyptian /a/ > /o/ = U > Coptic o; Egyptian /a:/ > /o:/ = U > Coptic ω

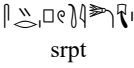
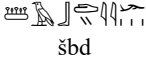
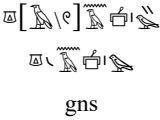

| | | | | | |
|-------|-----------|---|--------------------------------------|-----------|---------------------------------|
| III.1 | stag, ram |  | jA.yU.rA ↓ jAyUrA | *ʔvy'o:rv | ειογλ j'u:i |
| III.2 | sea |  | yU.m0 ↓ yUm | *y'om | ειομ j'om |
| III.5 | a fish |  | b0.Ur.y(U)/(U)y ↓ bUry(U)/(U)y | *b'oryv | ϭορϭ (B/B/S) b'orə b'o:rə |

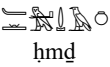
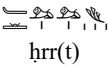
| | | | | | |
|--------|--------------------------|---|--|-------------------------|--------------------------------|
| III.9 | stronghold |  mktṛt ₁ | mAk.dU.Ur(ə) ↓ mAkUUr(ə) | *mvkd'ol | μεστο/ωλ (B/S) mæk't' o/o:l |
| III.15 | veils, thin cloth, purse |  ḥrd | ḥ ^o U.U ^r rd ↓ ḥ ₂ U ^r d | *ḥ ₂ 'ord(v) | ϣορτ š'ort |
| III.16 | leaf, lotus |  srpt | sA. ^r r0.pU.t(A) ↓ sA ^r pU ^t (A) | *svrp'ot(v) | σαρπ/φο/ατ (O/B) šārp'ot |
| III.17 | staves, rods |  šbd | šA.b0.Ud.y(A) ↓ šAbUdy(A) | *švb'odyv | ϣβοτ (B) šəb'otə |
| III.21 | violence, injustice |  gns | gA/U.n0.sA ↓ gA/U ⁿ sA | *g'on ^s v | γονκ k'ons |

Egyptian /i:/, /u:/ = U > Coptic η, ι

| | | | | | |
|--------|-----------------------|---|----------------------------|--|---------------------------|
| III.11 | vinegar |  ḥmḍ | ḥU.m0.ḍ(A) ↓ ḥUmḍ(A) | *ḥ'i:/u:mvḍ(v) *ḥ'i/umḍv < Sem. *ḥumšv | ημηχ ιμηχ h'e(:)mḍʒ |
| III.12 | flower |  ḥrr(t) | ḥU.rU.Ur ↓ ḥUrUr | *ḥvr'i:/u:rv | ηρηε hr'e:rə |
| III.14 | road, street, quarter |  ḥr | ḥ0.Ur ↓ ḥUr | *ḥ'i:/u:rv < Sem. *ḥur(r)v | ηρ h'i:r |

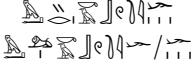
Finally, 2 words display a stressed vowel preceded by a /k/. All of them are written either with $\text{𓆎} = kU/Uk$ or with $w = U$. They are:

| | | | | | |
|--------|--------------|--|---|------------|---------------------|
| III.7 | chariot |  mrkbt | mA. ^r r0/Ur.k0.Ub.tA ↓ mA/Ur ^k Ubt(A) | *mvrk'obtv | βρσοογτ bærk'owt |
| III.20 | sole of foot |  kp | k0.Up ↓ kUp | *k'op | κοπ k'op |

§6 Egyptian *i/*u and *i:/*u: in light of the Semitic evidence

The present interpretative model allows to define the Egyptian vocalisations of words for which the Coptic data alone are ambiguous. In particular, Coptic vowels $\epsilon = /e/$, $\eta = /e:/$, and in some cases $\iota = /i:/$ can derive from both the Egyptian vowels /i/ and /i:/, and /u/ and /u:/, and there is generally no way to determine the right ancestor without external data.⁴⁵ Since however /i/ and /i:/ are *non-back* vowels, while /u/ and /u:/ are *back* vowels, they are distinguished in group writing transcriptions by the absence or presence of the marker *w*. Some of these words appear to be Semitic loans, and the comparison with related Semitic forms, when available, confirms the validity of this approach.

As discussed in the introduction, using Semitic data to establish the vocalic value of the groups is problematic for various reasons. Semitic forms, however, can provide precious information to verify the values defined through other sources like Coptic, as it is the case here. Naturally, issues concerning dialectal variations in Semitic, as well as the problem that the actual borrowing of a word may predate its first attestation in the Egyptian sources of decades or even centuries, have to be considered. As it appears, however, in almost all of the cases the evidence is very clear, and in agreement with the value suggested by the group writing spelling. Only one case is too ambiguous to be conclusive, and this because the Semitic evidence itself is problematic and contradictory.

Related Semitic forms can be identified for 13 words in the corpus whose stressed vowel can be reconstructed as either /i/ or /i:/, or /u/ or /u:/.

They are the following:

Coptic $\alpha/0 < A \sim i/$ – Semitic /i(:)/

• I.22 “shield”

| Earliest Attestation | Group Writing | Transliteration | Reconstruction | Semitic Prototype |
|----------------------|---------------|-----------------|----------------|-------------------|
| Period 1 | | qArAʕA | *q'i/ulʕv | *qilʕv |

Related vocalised Semitic forms:⁴⁶ Arb. *qilʕ* “sail” ; Arm. *qilʕā* “curtians”, “sail”; Heb. *qelacʕ* “slingshot” ; Syr. *qilʕ* “sling”, “sail” (Hoch 1994, 299, no. 432).

Notes: See Hoch for a discussion of the semantic shift.

• II.44 “heap”, “hillock”

| | | | | |
|----------|--|----------------------|---------------------------|----------|
| Period 2 | | tA ⁿ r(ə) | *t'i/u ⁿ r(rv) | *til(lv) |
|----------|--|----------------------|---------------------------|----------|

⁴⁵ Such as contemporary Akkadian transcriptions.

⁴⁶ Abbreviations: Akk. – Akkadian; Arb. – Arabic; Arm. – Aramaic; Heb. – Hebrew; Syr. – Syriac; Ugr. – Ugaritic.

Related vocalised Semitic forms: Akk. *tillu* “hill”; Arb. *tall* “hill”; Arm. *tillā* “hill”; Heb. *tel* “hill”; Syr. *tellā* “hill” (Hoch 1994, 356–7, no. 527).

Related non-vocalised Semitic forms: Ugaritic *tl* “hill”

Notes: Arabic *a* is possibly irregular.

Coptic $\alpha/e < U \sim /u/$ – Semitic $/u(:)/$

- I.15, II.30 “Syrian”

| | | | | |
|----------|---|-----|-------------|----------|
| Period 1 |  | hUr | *ḥ'i/ur(rv) | *ḥur(rv) |
|----------|---|-----|-------------|----------|

Related vocalised Semitic forms: Akk. *ḥurru* “Hurrian”, Heb. *ḥōrī* “name of a population” (see Loprieno 1995, 46)

Notes: Attested also as *Pa-ḥura* in the cuneiform transcriptions of the Egyptian name *p3-ḥr* in the Amarna letters (EA 122.31). Ultimately from Hurrian.

- I.6, II.14 “spear”, “javelin”

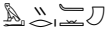
| | | | | |
|----------|---|------|-----------|--------|
| Period 1 |  | mUrḥ | *m'i/urḥv | *murḥv |
|----------|---|------|-----------|--------|

Related vocalised Semitic forms: Arb. *rumḥ* “spear”; Arm. *rumḥā* “spear”; Heb. *rōmah* “spear”; Syr. *rumḥā* “spear” (Hoch 1994, 139, no. 179)

Related non-vocalised Semitic forms: Ugaritic *mrḥ* “spear”; Old South Arabic *rmḥ* “spear”

Notes: Ugaritic present the same *r-m > m-r* metathesis attested in the Egyptian form, thus suggesting a northern origin for the loan.

- II.13 “bean”

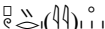
| | | | | |
|----------|---|---------|-------------|-------|
| Period 2 |  | pUr(yA) | *p'i/ur(yv) | *pu:l |
|----------|---|---------|-------------|-------|

Related vocalised Semitic forms: Arb. *fūl* “ful beans”; Arm. *pōlā* “ful beans”; Heb. *pōl* “ful beans” (Hoch 1994, 118, no. 150)

Related non-vocalised Semitic forms: Phoenician *pl* = “(ful?) beans”

- II.49 “jar”, “bowl”

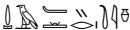
| | | | | |
|----------|---|---------|-------------|-----------|
| Period 2 |  | dAḥUrtA | *dvh'i/urtv | *švluḥi:t |
|----------|---|---------|-------------|-----------|

Related vocalised Semitic forms: Amarna Cananite *šillaḥta* “a jar”; Arm. *šəluḥūtā* “flask”; Heb.1 *šallahat* “dish”; Heb.2 *šəloḥūt* “jar”; Syr. *šəluḥūtā* “flask” (Hoch 1994, 394, no. 593).

Notes: the Egyptian form seems to come from a form akin to Arm., Heb.2 and Syr., with consequent metathesis and deletion of unstressed /i/ thus: Sem. *švluḥūt > Eg. *švluḥit > Eg. *švḥultv.

Coptic /h < A ~/i:/ – Semitic /i(:)/

• II.32 “lettuce”, “garlic”

Period 2  h₂AtAnA *h₂vṭ'i:/u:nv | *ḥasi:nv

Related vocalised Semitic forms: Akk. *ḥašṣū* (pl.) “lettuce”; Arb. *ḥass* “lettuce”; Arm. pl. *ḥāsīn* (sg. *ḥāsā*) “lettuce”; Heb. *ḥāsīt* “leek plants (including garlic and onions)”; Syr. *ḥassatā* “lettuce” (Hoch 1994, 253, no. 355)

Notes: Akkadian always plural. The Egyptian form likely comes from a plural with nunantion, akin to the Aramaic form. See also Hittite *ḥa-az-zu-wa-ni-iš* “lettuce” and Sumerian *ḥi-iz^{SAR}* “lettuce”

• III.23 “shrine”, “naos”, “inner sanctuary”

Period 3  dAbAr *dvb'i:/u:r | *dōbi:r

Related vocalised Semitic forms: Heb. *dābīr* “inner sanctuary” (Hoch 1994, 376, no. 561)

Related non-vocalised Semitic forms: Punic *dbr* “inner sanctuary”

Notes: the Egyptian form was clearly borrowed from a dialect where the stress had already moved to the last syllable, like in Hebrew.

It is also worth noting that at this time the length of the Egyptian vowels is clearly not conditioned any more to the nature of the syllable in which they appear, and therefore a long vowel /i:/ may be used to render a Semitic /i:/ even in a close syllable, as indicated by the group .

• III.13 “commerce”, “associate”, “companion”

Period 3  ḥAbAr *ḥvb'i:/u:r | *ḥaber

Related vocalised Semitic forms: Heb. *ḥāber* “associate” (Hoch 1994, 241, no. 333).

Related non-vocalised Semitic forms: Arb. *ḥbr* “to negotiate”

Notes: it is impossible to say if it was borrowed as /i:/ and then turned into /e:/ within Egyptian, or if it was already borrowed as /e:/. The Egyptian form was clearly borrowed from a dialect where the stress had already moved to the last syllable, like in Hebrew.

Coptic /h < U ~/u:/ – Semitic /u(:)/

• I.14, II.29, III.14 “road”, “street”, “quarter”

Period 2  ḥUr *ḥ'i:/u:rv | *ḥur(r)v

Related vocalised Semitic forms: Akk. *ḥurru* “hole”, “cave”; Heb. *ḥōr* “hole” (Hoch 1994, 247, no. 343)

Notes: see Hoch for the semantic development “hole”, “cave” > “street”, which is attested in the Egyptian sources.

• II.45 “oven”

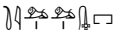
Period 2  tArUr *tvr'i:u:r(v) | *tv(n)nu:r(v)

Related vocalised Semitic forms: Akk. *tinūru* “oven”; Arb. *tannūr* “oven”; Heb. *tannūr* “oven”; Syr. *tannūrā* “oven” (Hoch 1994, 359, no. 351).

Related non-vocalised Semitic forms: Ugaritic *tnrr* “oven”

Notes: the first /r/ of the Egyptian form is usually assumed to be due to assimilation to the second /r/ (so Hoch). I wonder however if it could indicate that the word originates from a northern dialect akin to Ugaritic. If we assume a vocalisation **tvnrur* for the Ugaritic form, a loan from a similar form with subsequent simplification of the cluster **tvnrur* > *tv(r)rur* could also be a valid explanation.

• II.25, III.11 “vinegar”

Period 2  ḥUm(A)ḏ(A) *ḥ'i:u:mvd(v) | *ḥumšv
*ḥ'i/umḏv

Related vocalised Semitic forms: Arm. *ḥūmḥā* “vinegar”; Heb. *ḥōmēṣ* “vinegar” (Hoch 1994, 228, no. 316)

Related non-vocalised Semitic forms: Epigraphic Hebrew *ḥmṣ* “sour wine”, Ugaritic *ḥmṣ* “sour wine”.

Coptic $\Delta/0 < A \sim i/$ – Semitic non-conclusive

• II.37 “ashes”, “cinder”, “embers”

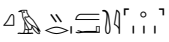
Period 2  qArmAtA *k'i/urmv(t) | —

Related vocalised Semitic forms: Akk. *gumāru* “burning coal”; Arb. *jamra* “live coal”; Arm. *gūmartā* “burning coal”; Syr. *gəṃurtā* “live coal” (Hoch 1994, 301, no. 435).

Related non-vocalised Semitic forms: Ugaritic *gmr* “burning coal”

Notes: The Semitic evidence is contradictory and inconclusive, and does not allow to suggest a single common prototype. The Akkadian form is a hapax, and it is likely directly related with the Aramaic one. It is however unclear if it is a loan from Akkadian into Aramaic, or from Aramaic into Akkadian (Abraham and Sokoloff 2012, 32). The Arabic form is related, but displays a clearly different vocalic pattern. The Egyptian form could derive from yet another unattested Semitic form characterised by a vowel /i/.

above. For instance, the spelling $\overline{\text{𐤀𐤁𐤂𐤃}} \overline{\text{𐤄𐤅𐤆𐤇}} = \zeta A.n.r0.Ur = \zeta A^n r Ur = * \zeta v^n r' o : r v$ can be analysed as an instance of environment 2, while the alternative spelling $\overline{\text{𐤀𐤁𐤂𐤃}} \overline{\text{𐤄𐤅𐤆𐤇}} = \zeta A.n.rU.yr0 = \zeta A^n r Ur = * \zeta v^n r' o : r v$ can be associated with environment 4a).

The reasons for favouring one spelling over the other are not clear, although the fact that most words seem to be written rather consistently in only one specific way suggests that the phenomenon was not totally random. Further studies, however, would be needed to identify the underlying rules, if they existed.

Right now, we can only observe that in the case of the environment 1), it is likely that a $w = U$ after the first consonant can only be pronounced there where it is written, because as far as we know, pre-Coptic Egyptian words could not begin with a stressed vowel, but only with a consonant (Loprieno 1995, 37, 40).

Moreover, the third environment is characterised by the presence of a $w = U$ in two consecutive groups, such as in the case of $\overline{\text{𐤀𐤁𐤂𐤃}} \overline{\text{𐤄𐤅𐤆𐤇}} = tA.rU.Ur = tArUr = *tvr'u:r(v)$ (II.45). It appears that in most cases, such groups share the same vowel, and at the same time all *back* vowels between identical consonants attested in the corpus are spelled in this way.⁴⁷ This consistency in spelling can hardly be accidental. One can thus suggest the presence of an orthographic rule according to which a *back* vowel between two identical consonants should be spelled by reduplicating the corresponding $c-w$ group. However, sequences with *back* vowel between different vowels, namely $-c_1-w + c_2-w-$, are also attested. In these cases, the reasons for such spellings are unclear, but it is reasonable to assume that, like the previous ones, these sequences should also be interpreted as $-c_1-w + c_2-w- = -c_1U + Uc_2- = -c_1Uc_2-$. Some caution, however, is due: since the nature of the unstressed vowels remain out of our reach, one cannot exclude *a priori* that, at least in some cases, such spellings were indeed meant to transcribe a $-c_1U + c_2U- = -c_1Uc_2U-$ sequence.

Finally, the data for Environment 4 strongly suggest that within a word, a CU group is by far more likely to transcribe a CU sequence rather than a sequence UC . This seems to be especially true when such group corresponds to the second consonant of the word (i.e. a $\#cv.cU-$ context): in 7 attestations over 9, such groups transcribe CU sequences. It would be tempting to correlate this observation with Environment 1, and to suggest that a CU group in second position, i.e. in a $\#cv.cU-$ syllabic sequence, can be assumed to represent CU rather than UC , because a syllabic sequence $\#cU.c-$ would already be covered by Environment 1, making a spelling $\#c0.UC- = \#c.UC-$ for such syllabic sequence rather superfluous.

However, the presence in the corpus of two words, namely $\overline{\text{𐤀𐤁𐤂𐤃}} \overline{\text{𐤄𐤅𐤆𐤇}} = h0.Ub.sA = hUb(A)sA = *h'i:u:bvsv$ (II.27) and $\overline{\text{𐤀𐤁𐤂𐤃}} \overline{\text{𐤄𐤅𐤆𐤇}} = b0.Ur.y(U)/(U)y = bUry(U)/(U)y = *b'oryv$ (III.5), which do use the spelling $\#c0.UC-$ to transcribe a sequence $\#cUc-$, calls for attention. The name of the city of Ugarit, usually written in the Egyptian texts as $\overline{\text{𐤀𐤁𐤂𐤃}} \overline{\text{𐤄𐤅𐤆𐤇}}$ (see Gauthier 1925–1931, I.110 for examples) and to be read as $\rho 0.Uk.rA.t(A) =$









47 The only exception is $\overline{\text{𐤀𐤁𐤂𐤃}} \overline{\text{𐤄𐤅𐤆𐤇}}$ = “sparrow” (II.46), which is spelled in two ways, namely $\overline{\text{𐤀𐤁𐤂𐤃}} \overline{\text{𐤄𐤅𐤆𐤇}}$, thus according to the rule, but also $\overline{\text{𐤀𐤁𐤂𐤃}} \overline{\text{𐤄𐤅𐤆𐤇}}$, thus in a irregular way. In light of what just discussed, the second spelling may be a scribal mistake.

§8 Diachronic analysis

Since some of the words of the corpus are attested in different periods, the model presented in this book can be verified also from a diachronic perspective. In particular, there are 21 words attested in more than one period, and the main phonological changes postulated for the Egyptian vowels can be observed taking place through them. In particular:

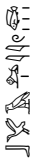
Coptic o = /o/ < Egyptian /a/

a)

| item | Period I | | | Period II | | | Period III | | |
|--------|----------|--------------------------|--|-----------|--------------------------|--|------------|--------------------------|---|
| | id | vocalisation at the time | attested form | id | vocalisation at the time | attested form | id | vocalisation at the time | attested form |
| sea | I.2 | *y'am |  yAm(A) | II.2 | *y'am |  yAm(A) | III.2 | *y'om |  yUm |
| a fish | I.4 | *b'ar(yv) |  bAr(yA) | II.9 | *b'aryv |  bAryA | III.5 | *b'oryv |  bUry(U) |
| lotus | I.17 | *svrp'at |  sArpAt | – | *svrp'at | – | III.16 | *svrp'ot(v) |  sArpUt(A) |
| couch, | I.24 | *kvl'ak(kvrv) |  kUrAkUrA | II.41 | *kvl'ak |  kArAk(A) | – | *kvl'ok | – |
| bed | | | | | | | | | |
| krkr | | | | | | | | | |

In the Coptic dialects in which it is attested, such as Sahidic and Bohairic, the shift /a/ > /o/ is usually assumed to have taken place at some point around or after 1000 BCE (see above §3.1). This development can be seen in various words of the corpus. Two of them are attested in all the periods, while one is attested only in the first two periods, and one only in the first and last. All these words are spelled without any *w* in Period 1 and 2. This is what one would expect, as at that time their stressed vowel was still the *non-back* vowel /a/. In the third period, instead, all these words are written with *w*, which implies that the presence of a *back* vowel. This, again, is exactly what one would expect, as by that time the stressed vowel /a/ is assumed to have turned into /o/.

b)

| | | | | |
|----------------------------------|--------------------------------|------------------------------|-------------------------------|-------------------------|
| stronghold mktṛt _i | I.9 *mvkt'a(:)(v) 𓄀𓄁𓄂𓄃𓄄𓄅 | II.20 *mvkt'ar 𓄀𓄁𓄂𓄃𓄄𓄅𓄆 | III.9 *mvkt'or 𓄀𓄁𓄂𓄃𓄄𓄅𓄆𓄇 | 𓄀𓄁𓄂𓄃𓄄𓄅𓄆𓄇𓄈𓄉 mAktUṛ(ə) |
|----------------------------------|--------------------------------|------------------------------|-------------------------------|-------------------------|

In addition, there is one word that in theory, according to the Coptic attestations, may have displayed both an /a/ > /o/ or a /a:/ > /o:/ . The vocalisation in Period I cannot be determined, as at the time both vowels would have been perceived as *non-back* vowels. The same stands true for Period 3, whose spelling indicates a *back* vowel that could correspond to both /o/ and /o:/ . However, the fact that the spelling of Period 2 implies a *non-back* vowel, rather than a *back* vowel, suggests that this word was vocalised with /a/ > /o/, as an /a:/ should have already turned into /o:/ in Period 2, and therefore should have been indicated in writing with a w. This therefore indicates that the Coptic variant with /o/ is the direct reflex of the Egyptian form, while the variant with /o:/ is likely a secondary development.

Coptic ω = /o:/ < Egyptian /a:/

| | | | | |
|---|--|-----------------------------------|-----------------------------------|--|
| stafis, rods (pl.) šbd(t _i) | I.18 *švb'adyv / *švb'a:dv 𓄀𓄁𓄂𓄃𓄄𓄅𓄆𓄇𓄈𓄉 | II.34d *švb'adyv 𓄀𓄁𓄂𓄃𓄄𓄅𓄆𓄇𓄈𓄉 | III.17 *švb'odyv 𓄀𓄁𓄂𓄃𓄄𓄅𓄆𓄇𓄈𓄉 | 𓄀𓄁𓄂𓄃𓄄𓄅𓄆𓄇𓄈𓄉𓄀 šAbAdə 𓄀𓄁𓄂𓄃𓄄𓄅𓄆𓄇𓄈𓄉𓄀 šAbUd(ə) |
| | | II.34b *švb'o:dv 𓄀𓄁𓄂𓄃𓄄𓄅𓄆𓄇𓄈𓄉 | | 𓄀𓄁𓄂𓄃𓄄𓄅𓄆𓄇𓄈𓄉𓄀 šAbUdy(A) |

The plural form of the word *šbd(t_i)* is attested in two variants in Coptic, one with stressed o = /o/ and one with stressed ω = /o:/ . Both forms are recognisable in Late Egyptian. The vocalisation of these two forms cannot be told apart either in Period 1, when both displayed a *non-back* vowel (/a/ or /a:/), nor in Period 3, when both such vowels had become *back* vowels (/o/ or /o:/). By contrast, they can indeed be distinguished in Period 2, when /a/ was still /a/ and was still unmarked, while /a:/ had already shifted to /o:/ and was thus marked with w. These parallel versions, therefore, confirm the development of both the shifts /a:/ > /o:/ and /a/ > /o/. The form attested for Period 3 can be reconstructed with a short /o/ because of the presence of 𓄀, which indicates closed syllable.

Coptic ɪ = /i:/ < Egyptian /i:/

| | | | | | | | | | |
|-----------------------|---|----------------|---|-------|----------------|---------|--------|---------------|---------|
| lentil ϥršn | — | *ϥvrš' i:/u:rv | — | II.5 | *ϥvrš' i:/u:rv | ϥAršAnA | III.4 | *ϥvrš' i:/u:n | ϥAršAnA |
| burnt-offering qrr | — | *qvr' i:/u:rv | — | II.38 | *qvr' i:/u:rv | qArArA | III.18 | *qvr' i:/u:rv | qArArA |

It is usually assumed that the Coptic vowel ɪ = /i:/ derives either from an earlier vowel /i:/, or from a vowel /u:/ when the stressed vowel is in proximity of /r/ or after a pharyngeal (Loprieno 1995, 48; Peust 1999, 231). Since neither of these conditions apply to the case of ϥAršAnA, it can be assumed that Coptic ɪ = /i:/ < /i:/. The word is written without -w in both Period 2 and 3, while it is not attested in Period 1. This spelling implies a stressed *non-back* vowel, as expected in the case of Coptic ɪ = /i:/ < /i:/.

The same stands true also for the word qrr: although the Egyptian spelling display two ⲓ = r, the Coptic form suggest that this consonant was actually pronounced /r/. The vowel can thus be reasonably reconstructed as /i:/.

Coptic ɨ = /e:/ < Egyptian /i:/

| | | | | | | | | | |
|---------------|-----|-------------|-------|-------|-------------|-------|---|-------------|---|
| bucket, bs | I.5 | *b' i:/u:sv | ϥAršA | II.11 | *b' i:/u:sv | ϥAršA | — | *b' i:/u:sv | — |
|---------------|-----|-------------|-------|-------|-------------|-------|---|-------------|---|

The development Egyptian /i:/ > Coptic /e:/ = ɨ is attested by one word in the corpus. Its spelling suggests the presence of a *non-back* vowel during both Period 1 and 2. Since the group writing orthography does not allow to distinguish between /i:/ and /e:/, being all *non-back* vowels, it is not possible to determine when the specific shifts took place.

As said above, it is usually assumed that the Coptic vowel $\text{h} = /i:/$ may come from an earlier vowel $/u:/$, if next to $/r/$ or after pharyngeal. One word of the corpus, $\text{h} \text{U} \text{m} \text{d} = \text{hr} = 2\text{p}$, attests this development. It is likely that $\text{h} \text{U} \text{m} \text{d} = \text{hr}$ comes from Semitic $\text{hur}(ru)$ (Hoch 1994, 247–8, no. 343; Loprieno 1995, 48), and thus displayed an original $/u(:)/$ vowel. The word $\text{h} \text{U} \text{r} \text{U} \text{r} = \text{hr}$ is written with $w = U$ in all the three periods, which on the one hand confirms the original *back* nature of the stressed vowel and on the other suggests that the shift $/u:/ > /i:/$ took place at some point after Period 3. This is a crucial observation for the understanding of such phonological development, as discussed more specifically below (§10). As for $\text{h} \text{U} \text{m} \text{d}$, no external evidence can be used to infer the nature of the original vowel. The Egyptian transcriptions however consistently point to a *back* vowel, and the fact that no change is observed between the spelling of period I and period II confirms that the shift $/u:/ > /i:/$ took place at a later date.



Coptic $\text{h} = /e:/$ or $/\text{ø}:/ <$ Egyptian $/u:/$

| | | | | | | | | | |
|---------------------------------------|------|--|---|-------|--|---|--------|--|---|
| vinegar | – | * $\text{h} \text{U} \text{m} \text{v} \text{d}(\text{v})$ | – | II.25 | * $\text{h} \text{U} \text{m} \text{v} \text{d}(\text{v})$ | | III.11 | * $\text{h} \text{U} \text{m} \text{v} \text{d}(\text{v})$ | |
| $\text{h} \text{m} \text{d}$ | – | – | – | | | $\text{h} \text{U} \text{m} \text{d}(\text{A})$ | | | $\text{h} \text{U} \text{m} \text{d}(\text{A})$ |
| flower | I.12 | * $\text{h} \text{v} \text{r} \text{U} \text{r}$ | | II.26 | * $\text{h} \text{v} \text{r} \text{U} \text{r}$ | | III.12 | * $\text{h} \text{v} \text{r} \text{U} \text{r}$ | |
| $\text{h} \text{r}(\text{t})$ | | | $\text{h} \text{U} \text{r} \text{U} \text{r}$ | | | $\text{h} \text{U} \text{r} \text{U} \text{r}$ | | | $\text{h} \text{U} \text{r} \text{U} \text{r}$ |
| scorpion | I.25 | * $\text{d} \text{v} \text{r} \text{U} \text{y} \text{v}$ | | II.48 | * $\text{d} \text{v} \text{r} \text{U} \text{y} \text{v}$ | | – | * $\text{d} \text{v} \text{r} \text{U} \text{y} \text{v}$ | – |
| $\text{d} \text{r} \text{y} \text{t}$ | | | $\text{d} \text{A}^{\text{r}}(\text{r}) \text{U} \text{y} \text{v}$ | | | $\text{d} \text{A}^{\text{r}}(\text{r}) \text{U} \text{y} \text{A}$ | | | – |

The Coptic vowel h may derive from either an earlier $/i:/$ or $/u:/$.







Three words in the corpus attest the second development. In the case of $\text{h} \text{U} \text{m} \text{d}$, the $/u:/$ nature of the stressed vowel is supported by the Semitic parallels (§6). In the case of $\text{h} \text{U} \text{r} \text{U} \text{r}$ and $\text{h} \text{U} \text{r} \text{U} \text{r}$, instead, it can be inferred by the spelling with w , suggesting the presence of a *back* vowel. As said above (§3.1), the exact date of the development $/u:/ > \text{h}$ is not clear. Moreover, as mentioned, it seems that Coptic h corresponded to two different *non-back* phonemes, namely an *unrounded* one – usually described as $/e:/$ – and a *rounded* one – usually described as $/\text{ø}:/$ –, although it is not clear how such Coptic phonemes would relate with the earlier $/i:/$ and $/u:/$. In any case, what emerges from the word discussed here is that one of the ancestors of Coptic h remained a *back* vowel at least until Period 3.

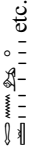
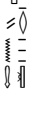

Coptic $\Delta = /a/ < /e/ < Egyptian /i/$

| | | | | | | | | | |
|---------|------|----------|---|-------|----------|---|--------|--------|---|
| husband | I.10 | *h' i/uy |  | II.22 | *h' i/uy |  | III.10 | *h' ey |  |
| hy | | | hAy | | | hAy | | | hAy |

The development Egyptian /i/ > /e/ > Coptic /a/ = Δ is attested by one word, whose spelling suggests the presence of a *non-back* vowel during all the three Periods. Since the group writing orthography does not allow to distinguish between /i/, /e/ and /a/, being all *non-back* vowels, it is not possible to determine when these shifts took place.

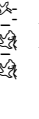
Coptic $\Delta = /a/ < /e/ < Egyptian /u/$

| | | | | | | | | | |
|-------------|------|---------------------------|---|-------|---------------------------|--|--------|---------------------------|---|
| pebble | — | * ζ' i/ur | — | II.3 | * ζ' i/ur |  etc. | III.3 | * ζ' e ^r |  |
| ζ^r | | | — | | | ζ U ^r | | | ζA^r |
| laws | I.11 | *h' i/up |  | II.23 | *h' i/up |  | — | *h' i/up | — |
| hp | | | hUp | | | hUp | | | — |
| Syrian | I.15 | *h' u/ir(rv) |  | II.30 | *h' u/ir(rv) |  | — | *h' u/ir(rv) | — |
| hr | | | hUr | | | hUr | | | — |
| sparrow | — | * \bar{t} i/u \bar{t} | — | II.46 | * \bar{t} i/u \bar{t} |  | III.22 | * \bar{t} e \bar{t} |  |
| t \bar{t} | | | — | | | tU \bar{t} | | | tA \bar{t} A |

Egyptian /u/ evolves into /e/ and then into Coptic /a/ = Δ , except in proximity of sibilants, before / \bar{r} / < / \bar{r} / < / \bar{r} / < / \bar{r} / < / \bar{r} / < / \bar{r} / < /w/ and possibly in other phonological contexts, where it may be preserved up to Coptic as /e/ = e. The first shift /u/ > /e/ is usually assumed to have taken place at some point around 1000-800 BCE (Loprieno 1995, 39 – see above §3.1), while the shift /e/ > /a/ = Δ appears to be attested by two words in the corpus, both attested in Period 2 and 3 only. In both cases, the spellings from Period 2 indicate a *back* vowel, while those of Period 3 indicate a *non-back* vowel, thus suggesting that the first phonological shift /u/ > /e/ took place at that time, around 1000 BCE, as expected. This is indirectly confirmed by a two additional words, namely  /  = hr, which are attested in Periods 1 and 2. They are both spelled with w in both periods, thus suggesting that at the time the shift had not taken place yet.

The correspondence between the readings of these words in various periods and the expected evolution of the vocalisation validates the interpretation of the group writing presented in this study. At the same time, it also confirms and in some cases allows refining our understanding of the evolution of the Egyptian vocalic system.

§9 Statistical analysis

§9.1 Theoretical background

Given the intrinsic leeway of a system that marks only two vocalic classes, and in which groups encoding *back* vowels can be read both as *cU* and as *Uc*, it is reasonable to wonder if the results presented above may actually be due to mere chance. This issue can be rephrased as a very specific probability question: with the present rules, what is the probability that a group with *-w* will always correspond to a stressed *back* vowels (either through a reading *cU* or a reading *Uc*), while a group without *-w* will always correspond to a stressed *non-back* vowel? The statistical problem underling this question is difficult to solve in a mathematical way, because multiple variables⁴⁹ play a role in the outcome. This problem, however, can be effectively addressed with an empirical statistical approach based on the so-called Monte Carlo methods.⁵⁰

Basically, Monte Carlo methods rely on repeated random sampling to obtain empirical estimations of the probability of a given event. For instance, let us assume that we have a deck of cards. We draw 10 cards from it, and we find out that all of them are red. What is the probability of such an outcome occurred by mere chance, rather than because, for instance, someone manipulate the deck and put only red cards at the top? A possible Monte Carlo approach to solve this problem would be to perform multiple trials, each consisting in re-shuffling the deck and re-drawing 10 cards, recording each time how many black cards and how many red cards have appeared.

If enough trials are performed, the observed frequencies of the various outcomes will represent a good empirical approximation of their actual probability. If we organise the outcomes in a chart, starting from a “10 black cards” outcome and progressively moving toward a “10 red cards” one, the frequencies and therefore the probabilities of such outcomes will be distributed according to a so-called Gaussian or bell curve. The outcome “5 red, 5 black” will have the highest probability,⁵¹ and the other outcomes will be distributed around it in a decreasing way, tending to zero toward the two edges of the chart.

A similar Monte Carlo approach can be used to assess the probability, and therefore the likelihood, that the matches between the reconstructed vocalisations and the readings of the group writing spelling suggested in this study may be due to mere chance.

The problem can be framed as follow: the number of matches between reconstructed vocalisations and suggested readings (which equals the very number of words in the corpus, as all of them can be regularly explained according to the current model) has to be compared with the number of matches that can be obtained between the same vocalisa-

49 For instance, one has to consider that in Egyptian the frequencies of stressed *back* and *non-back* vowels are different, and that such frequencies vary depending both on the syllable in which they appear and, more in general, on the specific phonemic inventory of each period.

50 For a good, general introduction to Monte Carlo methods, see Fishman 1995.

51 Since there is an equal number of red and black cards in a deck, a 50%-50% outcome is the most probable one.

tions and the same readings when they are paired at random, over multiple trials. A match is obtained every time that, in such randomly generated pairs, the group writing spelling can be explained as a transcription of the paired vocalic pattern, according to the rules suggested for the model presented here.

If the results presented in this book were truly accidental, one would expect cases in which all group writing spellings match the corresponding randomly paired vocalic patterns to be relatively common, to be a recurrent outcome over multiple trials, and therefore to have a rather high probability to occur by chance. By contrast, if such cases happen to be overall rare, then this would strongly suggest that the results presented in this book are statistically significant and are likely not due to chance. This, in turn, would strongly suggest that the interpretative model as a whole is valid.

Such a Monte Carlo test can be easily implemented into a simple computer program that automatically performs n trials and counts the outcomes. The test itself can be built and encoded in various ways. A particularly easy one consists in creating an *array_1* with all the vocalic patterns attested in the corpus, an *array_2* with all the attested group writing spellings, and a *match_table* listing the various pairs of *vocalic pattern – group writing spelling* that should be considered as valid matches. The program will then perform multiple trials in which the items in *array_1* and *array_2* are first shuffled and then randomly paired. The resulting pairs will then be assessed against those recorded in the *match_table*, and the valid matches will be counted for each trial.







It is important to note that the corpus is composed of words displaying different numbers of syllables, and which therefore have vocalic patterns and group writing spellings of different lengths. In particular, most of the words of the corpus have either 2 or 3 syllables, while only a few are longer. This aspect has to be considered while performing the Monte Carlo test, because it is clear that each vocalic pattern should be paired only with spellings of the same length. It would not make much sense to compare, for instance, a vocalic pattern with two syllables, with a spelling composed of three groups. In order to deal with this issue, the corpus has been divided into batches of words of the same length. The Monte Carlo test has then been performed independently on the batches of disyllabic and trisyllabic words, which constitute the majority of the corpus. Longer words have been ignored, because they are too few to be meaningfully tested. I have implemented the procedure just described as a Python script, which is freely available in my github repository (https://github.com/MKilani/LingAeg_group_writing_Monte_Carlo_test).

In order to compare them, vocalic and spelling patterns need to be transcribed and encoded in a coherent way. To do so, a few factors need consideration. First, obviously, only a distinction between *non-back* and *back* vowels is needed in the transcriptions of the vocalic patterns, because only such distinction is reflected in the group writing spellings. Since only stressed vowels have been studied in the this book, unstressed vowels can be ignored in the encoding of the words and in the subsequent assessment. It has to be noted that in some cases, it is impossible to reconstruct with any certitude if the stressed vowel was a *non-back* or a *back* vowel. This is the case, for instance, of the ancestors of Coptic *e*, which could be either /i/ or /u/ in Period 1 and 2. In these cases, the vocalic patterns must be transcribed in a way that can be matched both with the spellings implying a stressed

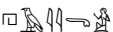
non-back vowel and with the spellings implying a stressed *back* one. Finally, as discussed above, preconsonantal *r-* and *n-* clustered with the following consonants. This means that from the point of view of group writing spellings, the sequences *r-* and *n-* + *consonant* behaved as single consonantal segments. Therefore, such clusters should be treated as single consonants in the transcription of the spelling patterns displaying them.

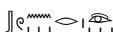
Table 3 provides a few illustrative examples of transcriptions of vocalic and spelling patterns.

Table 3 – Selected examples of transcriptions of vocalic and spelling patterns

| Id | Word | Meaning | Reconstructed Vocalisation | Spelling | Vocalic Pattern | Spelling Pattern |
|-------|----------------|---------|----------------------------|---|-----------------|------------------|
| I.6 | spear, javelin | | *m'urhʋ |  | cUc | ccW |
| I.10 | husband | | *h'i/uy |  | cA/Uc | c3/0c |
| I.11 | law(s) | | *h'i/up |  | cA/Uc | cWc |
| I.16 | wool, hair | | *svʕ'artv |  | ccAc | cc3/0c |
| II.8 | ball of eyes | | *b'i/uʔr |  | cA/Uc | cWc |
| II.30 | Syrian | | *h'ur(rv) |  | cUc | ccW |
| II.45 | oven | | *tvr'u:r(v) |  | ccUc | ccWcW |
| III.4 | lentil | | *ʕvrʂ'i:nv |  | ccAc | cc3/0c |
| ... | ... | | ... | ... | ... | ... |

Notes:

A = stressed *non-back* vowel; U = stressed *back* vowel; A/U = stressed vowel that can be reconstructed as either *non-back* or *back*; W = presence of w in the spelling; 3/0 = presence of 3, or absence of any vocalic marked in the spelling; c = any consonant.

Table 4 lists all the possible pairs of *vocalic pattern – group writing spelling* that count as positive matches.

Table 4 – List of vocalic patterns and matching spellings for disyllabic and trisyllabic words

| Pairs <i>vocalic pattern – group writing spelling</i> for disyllabic words | | | |
|--|--------------------------------|------------------------|--------------------------------|
| <i>Vocalic pattern</i> | <i>Group writing spellings</i> | <i>Vocalic pattern</i> | <i>Group writing spellings</i> |
| cAc | c3/0c | cUc | cWcW |
| ccA | cc3/0 | ccU | ccW |
| cA/Uc | c3/0c | cA/Uc | cWc |
| ccA/U | cc3/0 | cA/Uc | ccW |
| cUc | cWc | cA/Uc | cWcW |
| cUc | ccW | ccA/U | ccW |

| Pairs vocalic pattern – group writing spelling for disyllabic words | | | |
|---|--------|--------|-------|
| cAcc | c3/0cc | ccUc | cccW |
| ccAc | cc3/0c | ccUc | ccWcW |
| cccA | ccc3/0 | cccU | cccW |
| cA/Ucc | c3/0cc | cA/Ucc | cWcc |
| ccA/Uc | cc3/0c | cA/Ucc | ccWc |
| cccA/U | ccc3/0 | cA/Ucc | cWcWc |
| cUcc | cWcc | ccA/Uc | ccWc |
| cUcc | ccWc | ccA/Uc | cccW |
| cUcc | cWcWc | ccA/Uc | ccWcW |
| ccUc | ccWc | cccA/U | cccW |

Notes:

A = stressed *non-back* vowel; U = stressed *back* vowel; A/U = stressed vowel that can be reconstructed as either *non-back* or *back*; W = presence of w in the spelling; 3/0 = presence of 3, or absence of any vocalic marked in the spelling; c = any consonant.

§9.2 Results

The Monte Carlo simulation described above has been independently performed on the disyllabic and on the trisyllabic words attested in the corpus. The words have been tested first divided by period, and then all together. The results are summarised in table 5.

Table 5 – Monte Carlo simulation: results

| Disyllabic words | | | | |
|-------------------|----------|----------|----------|----------------------|
| | Period 1 | Period 2 | Period 3 | All Periods together |
| Number of words: | 10 | 23 | 10 | 43 |
| Probability: | 1.917% | 0.049% | 0.393% | < 0.001% |
| Trisyllabic words | | | | |
| Number of words: | 11 | 26 | 11 | 48 |
| Probability: | 0.209% | < 0.001% | 0.011% | < 0.001% |

Notes:

Probabilities of obtaining by chance a positive match for all of the words attested in the corpus in each period and all together – number of trials: 100'000.

The graphic representations of the probabilities of random matches are provided in Appendix B.

The results are clear: in all the cases, the probability of obtaining by chance a valid match for each of the pairs is extremely low. In many cases, it is so low that it cannot even be precisely estimated. These sets of data unequivocally suggest that it is statistically very unlikely that the results presented in this book are due to mere chance, and therefore they provide strong additional evidence of the validity of the system.

§10 The development of Coptic н

As mentioned above (§3.1), the development /u:/ ~ /i:/ > н is a thorny issue in Egyptian historical linguistics. The evidence presented in this book provides some new relevant data. What emerges is that during all the three periods, Coptic н could correspond to both a *non-back* and a *back* vowel. This suggests that either these two vowels never fully merged, as suggested by some scholars (see Peust 1999, 228–30), or such merging took place after Period 3. This data are in agreement with what emerged from the preliminary study of the *w*-extended orthography, which also suggested the presence of two distinct vowels, a *back* and a *non-back* one, in correspondence of Coptic н in texts dating to Period 3 (Kilani 2017a). It is also worth to observe that the word $\square \text{𓆎} \text{𓆏} \text{𓆑} \text{𓆒} = hm$ (II.24), attested in the corpus only in Period 2 and spelled with 𓆑 , which implies a pronunciation **h'u:mv* with /u:/, is instead spelled without 𓆑 in Pap. BM EA 10474 (*Teachings of Amenemope*) 27.3,4, which dates to the 26th Dynasty (Laisney 2007, 6), thus suggesting a *non-back* stressed vowel, which may imply a pronunciation **h'e/ø:mv*. This could therefore indicate that the /u:/ > н (= /e:/ or /ø:/?) shift took place after the end of the 22nd Dynasty (i.e. after Period 3) but before the 26th Dynasty.

The specific nature of such *back* vowels cannot be specified on the basis of the evidence emerged from this book. It can only be said that a *non-back* and a *back* vowel were involved, but it is not possible to say if such vowels were maintained as /u:/ and /i:/ during the three periods, or if they underwent some minor shift that did not change their *back* and *non-back* nature, such as /i:/ > /e:/.

§11 The group 𐤊 – additional observations

As explained above, the few examples in the corpus show that the group 𐤊 encodes a *back* vowel and can be read as *dU* or *Ud*. This assumption can be confirmed on the basis of other attestations in toponyms, personal names, and words that have no direct descendant in Coptic and which, therefore, are not part of the corpus. I discuss them in detail here below.

• “Armant” (toponym)

| Attestations | Group Writing | Transliteration | Reconstruction | Prototype |
|--------------|----------------|-------------------------|----------------|-------------------|
| Period 3 | 𐤀𐤌𐤎𐤓𐤊 | mU ⁿ d(t)A/0 | *m'ont(v) | see Cpt. (ερ)ΜΟΝΤ |

Eg.: Gloss. Gol 4.15 (AEO I no. 332–3)

The spelling 𐤀𐤌𐤎𐤓𐤊 for the name of the city of Armant is attested once, in the Onomasticon of Amenope (no. 332). The name of the city is attested in Coptic as ϩΜΟΝΤ = (ə)rm'ont (S) and ερΜΟΝΤ = εrm'ont (B), in Greek as Ἐρμωνθις = ermōnthis and Ἐρμωνθις = ermonthiς and in Latin as Hermunthus, Hermonthes and Hermonthis.⁵² The name can be analysed as 𐤀𐤌𐤎 = “the city Ōn” and 𐤓𐤊 = “the God Montu”. The Coptic, Greek and Latin forms of this toponym suggest the presence of a stressed *back* vowel. The pronunciation *m'ont(ə) can thus be reconstructed for Period 3. The group writing spelling 𐤓𐤊 = m0-Und-t0 = mUnd/t perfectly reflects this pronunciation. This form provides a good example of 𐤓 = preconsonatal *n* being clustered with the following consonant, in this case *d*, thus resulting in 𐤓𐤊 = *n* + *d*-w = *nd-U* = *Und* (see above §4.3).

• “Ashdod” (toponym)



| | | | | |
|----------|----------------|--------|----------|------------|
| Period 3 | 𐤀𐤏𐤃𐤃𐤊 | jAsdUd | *ʔvsd'Ud | *ʔašdo:/ud |
|----------|----------------|--------|----------|------------|

Eg.: Gloss. Gol 4.4–5 (AEO I no. 263)

The city 𐤀𐤏𐤃𐤃𐤊 is attested only once in the Egyptian sources, in the Onomasticon of Amenope (no. 263). It is usually identified with the city of Ashdod, about 30 km South of Yaffa. Its name is attested in Hebrew as *ʔašdōd* (Joshua 11:22, 15:46,47; 1 Samuel 5:5,6,7, 6:17; 2 Chronicles 26:6; Isaiah 20:1; Jeremiah 25:20; Amos 1:8, 3:9; Zephaniah 2:4; Zechariah 9:6) and *ʔašdōda* (1 Samuel 5:1; Isaiah 20:1), in Assyrian Akkadian as ^{URU}*aš2-du-du* (e.g. SAA 17 082: r 6')⁵³ and in Greek as Αζωτος = *azōtos* (e.g. Herodotus II:157 – *z* < *šd* because of folk etymology?).

52 <https://www.trismegistos.org/geo/detail.php?tm=37278> – last visited: 23.5.2018.



53 See: <http://oracc.museum.upenn.edu/saao/saa17/corpus> – last visited: 23.5.2018.

All these forms present a sequence *dōd* or *dud*, which the Egyptians transcribed as 
 = *dU-Ud* = *dUd*.

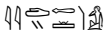
- “skilled”, “knowing”, “knowledgeable”

Period 2  *yUdʕA/0* *y'u:/o:d(v)ʕ(v) | *yo:diʕ

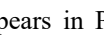
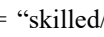
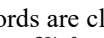
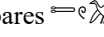
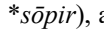
Eg.: EHT 1 (P.An. I) 17.8 = HoSW 58.64

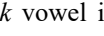
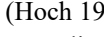
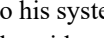
The word  appears in Papyrus Anastasi I in the expression  =  = “skilled/learned scribe” Hoch 1994, 58, no. 64. The meaning and Semitic prototypes of the two words are clear, but their vocalisation has been a subject of debate. Hoch compares  = *tUpAr*⁵⁴<?> with Biblical Hebrew *sōfer* = “scribe” (from a participle **sōpir*), and he correctly observes that the vocalisation of the Egyptian form, with a *back* vowel in the first syllable, points to a coastal North-West-Semitic dialect (Hoch 1994, 58). However, he is then puzzled by the vocalisation of ,⁵⁵ because according to his system it does not show any trace of the expected /a:/ > /o:/ shift. He thus concludes that either the spelling of  was inaccurate regarding the vocalisation, or the scribe mixed forms from two different dialects, one that underwent the Canaanite shift and one that did not. This problem disappears if we consider  = *dU/Ud* and therefore we interpret  as *y0-Ud-ʕA/0* = *yUdʕA/0*. This spelling implies the presence of a *back* vowel, and therefore perfectly reflects a North-West-Semitic prototype **yōdiʕ* = “knowing”, “who knows”, hence “skilled” (active participle - cf. Biblical Hebrew *yōdeaf*), which is what we would expect in a dialect that underwent the shift /a:/ > /o:/. It thus appears that the new reading suggested here not only provides a likely interpretation for this spelling, but it also elegantly solves the issue noticed by Hoch by showing that both  = *tUpAr* from **sōpir* or the like, and  = *yUdʕA/0* from **yōdiʕ* or the like come from a same single dialect that underwent the shift /a:/ > /o:/.

- “stand firm”, “hold one’s ground”

Period 2  *ʕAmUd* *ʕvm'Ud | *ʕa(:)mo:d

Eg.: O.Turin 57365 4 = HoSW 70.76

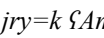
The word  is attested only once in the Egyptian sources, in Period 2, in the expression *jry=k ʕAmUd m p3 nhrn* = “you stand firm in Naharin”.  is certainly related with Semitic $\sqrt{\text{ʕ-m-d}}$ = “to stand firm” – see Akkadian *emēdu* = “to stand (near) by”, “to lean on”; Arabic *ʕ-m-d* = “to approach”, “to support”; Aramaic *ʕāmad* = “to place (G-stem)”, “to place (D-stem)”; Biblical Hebrew *ʕāmad* = “to stand (up against)”. The

54 He reads it, according to his system, as *tu=pi3=ra* Hoch 1994, 364.

55 He reads it as *ya=di=ʕa*, according to his system.

root is well attested in various North-West-Semitic languages, but it is common as a verb only in Hebrew. The Egyptian construction in which this word appears would require an infinitive, and in fact the vocalisation of $\text{𐎃} \text{𐎃} \text{𐎃}$, with a *back* vowel in the second syllable, could indeed correspond to a North-West-Semitic infinitive in a language that underwent the Canaanite /a:/ > /o:/ shift, as attested by the Biblical Hebrew infinitive $\text{𐤃} \text{𐤁} \text{𐤌}$.

- “Dor” (toponym)

| | | | | |
|----------|------------------------------|-----|-------|---------------|
| Period 3 | $\text{𐎃} \text{𐎃} \text{𐎃}$ | dUr | *d'Ur | ⋮ *do:r/*doʔr |
|----------|------------------------------|-----|-------|---------------|

Eg.: LES 5 1.8

The city of $\text{𐎃} \text{𐎃} \text{𐎃}$ is attested only once in the Egyptian sources, in the tale of Wenamun. It is usually identified with the city of Dor, about 30 km South of Haifa. Its name is attested in Hebrew as *doʔr* (Joshua 17:11) and *dōr* (1 Chronicles 7:29), and in Assyrian Akkadian as $\text{URU} \text{du-u}'\text{-ru}$ (Gilboa and Sharon 2016, 241). The *back* vowel present in all these forms is reflected in the use of the group $\text{𐎃} = dU$, which in Period 3 stands for /do/, /do:/ or /du:/.

- “amorous”, “lustful”, “lascivious”

| | | | | |
|----------|------------------------------|-----|-------|------------------------------|
| Period 2 | $\text{𐎃} \text{𐎃} \text{𐎃}$ | dUd | *d'Ud | ⋮ *do:/u:d / ⋮ *do/aw(i)d |
|----------|------------------------------|-----|-------|------------------------------|

- “Dod”, “Dud” (name, based on the previous one)

| | | | | |
|-------------|------------------------------|-----|----------|------------------------------|
| Period 1, 2 | $\text{𐎃} \text{𐎃} \text{𐎃}$ | dUd | *d'u(:)d | ⋮ *do:/u:d / ⋮ *do/aw(i)d |
|-------------|------------------------------|-----|----------|------------------------------|

Eg.: see HoSW 378–9.568 for attestations.

The word $\text{𐎃} \text{𐎃} \text{𐎃}$ and the name $\text{𐎃} \text{𐎃} \text{𐎃}$ have long been recognised as being related with the Semitic root $\sqrt{d(-w)-d}$ = “to love (et cetera)” – see Biblical Hebrew *dōd* = “lover”; *dōdīm* = “love-(making)”; Ugaritic *ddm* = “love”; Aramaic *dōda* = “lover”; Akkadian *dādū* “love-making”. Since the group 𐎃 has usually been read as *dy*, until now these words have been interpreted as *dydy*, *didi* and the like. However, as Hoch (1994, 379) points out, such a vocalisation is grammatically problematic and has no good parallel in any attested Semitic form. By contrast, reading the group 𐎃 as *dU/Ud*, and therefore the sequence $\text{𐎃} \text{𐎃}$ as *dU + Ud = dUd* solves the issue. The word $\text{𐎃} \text{𐎃} \text{𐎃} = dUd$, can then be compared with Hebrew and Aramaic *dōd(a)* = “lover” (Hoch 1994, 379). As for the name $\text{𐎃} \text{𐎃} \text{𐎃} = dUd$, it can be compared with $\text{Du-u}(\text{₂})\text{-du}$, attested in the Amarna letters as the name of an Egyptian official (EA 158:1,5,12,34; EA 164:1,10,16; 167:28; EA 169:16). This name is in turn clearly related with Biblical Hebrew *dāwid*. In fact, both the name attested in the Amarna letters and the Egyptian $\text{𐎃} \text{𐎃} \text{𐎃} = dUd$ could be interpreted as

renditions of some variant $dāwid$, for instance if we assume a contraction $dāwid > *dō(i)d$, or if we consider a variant $*dōw(i)d$ from a dialect that underwent the $\bar{a} > \bar{o}$ shift.

§12 The group ʕe

The group ʕe presents some peculiar characteristics and therefore deserves a specific discussion. This group is not attested in the corpus, as none of the nouns presenting it has a sure direct descendant in Coptic. ʕe, however, does appear in the Period 3 spelling of a toponym, ⲉⲩⲁⲩⲓⲗⲉⲓⲛⲓ = “Sile”, which is later attested in Latin, Greek and Coptic.

This spelling ⲉⲩⲁⲩⲓⲗⲉⲓⲛⲓ is recorded in the version of the Onomasticon of Amenope preserved in the papyrus known as the Golenischeff Onomasticon (Gardiner 1947, Vol. I, 27-9). Eight additional words characterised by a final ʕe are present in this papyrus. Three of them end with a sequence ⲩⲁⲩⲓⲗⲉ, which suggests they may be characterised by vocalic patterns comparable to that of ⲉⲩⲁⲩⲓⲗⲉⲓⲛⲓ. None of these words, however, survives in Coptic, and therefore their vocalisation cannot be externally verified.

The group ʕe appears in the Onomasticon also at the end of a few more words spelled in traditional orthography. Some of these words do survive in Coptic, and therefore they provide crucial information about the value and functioning of this group. Since the Onomasticon of Amenope provides a small but rich and coherent corpus, all words displaying a final ʕe attested in it are listed and singularly discussed in detail here below, at the end of this section.

§12.1 The group ʕe – interpretation

In the case of ⲉⲩⲁⲩⲓⲗⲉⲓⲛⲓ, such spelling can be interpreted as follow:

| | | | | | |
|----------|------------------|------------------------|---------|--|-----------|
| III Sile | ⲉⲩⲁⲩⲓⲗⲉⲓⲛⲓ ir | tA.rU.U' ↓ tArU' | *tʁr'u: | Lat.: Sile, Selle Gr.: Σελη Cpt.: σελη | < *səl'e: |
|----------|------------------|------------------------|---------|--|-----------|

Latin *Sile* and *Selle* are the earliest vocalised attestations of this toponym, as they come from the *Itinerarium provinciarum Antonini Augusti*, 171, 2 (ca. 300 CE) and from the *Notitia dignitatum*, Or. 28, 27 [b] (ca. 395–430 CE) respectively. The Greek and Coptic forms are instead later, as they both come from the Greek and Coptic acts of the council of Ephesus of 431 CE.⁵⁶ In their case, therefore, it is not possible to exclude a reciprocal, Greek-Coptic influence, and if so it is not possible to define the direction of such influence: the city is obviously in Egypt, and therefore it is likely that the Greek spelling reflects an Egyptian pronunciation. The Coptic spelling may also reflect the same pronunciation, and may thus truly be an indigenous rendition of the same name, but it could also be a back formation shaped on the Greek form.⁵⁷ There is hardly any way to solve this issue. However, even leaving aside the Coptic form, a few observations can be made: both the Greek form Σελη and the Latin *Sile* suggest a difference between the first and the

56 See: https://www.trismegistos.org/geo/authors_georef_list.php?tm=2109 (last visited: 13.05.2018)

57 Gauthier 1925–1931, VI 67 reports also a Coptic variant σεη, which looks like a truly Coptic spelling and not as an adaptation of the Greek one, but unfortunately he did not provide any source for this form.

- 1) most of them derive from Middle Egyptian roots which are usually assumed to have ended with a weak consonant $-j / -w$ or with $-ʒ$.
- 2) for those words that have a Coptic reflex, the corresponding Period 3 forms can be reconstructed as ending with a stressed *back* vowel, often followed by a glide. In particular: $\text{𓂏} \text{𓂏} \text{𓂏} - \text{HI} < *t'u:j$; $\text{𓂏} \text{𓂏} \text{𓂏} - \text{MOYI} < *m'o:j$; $\text{𓂏} \text{𓂏} \text{𓂏} - \text{MANNY} < *mvjn'u:w$; $\text{𓂏} \text{𓂏} \text{𓂏} - \text{NH/EI (B)} < *n'u:j$; $\text{𓂏} \text{𓂏} \text{𓂏} - \text{TO/OY} (S/B) < *t'o:w$ (see list below for detailed discussion).

The words $\text{𓂏} \text{𓂏} \text{𓂏} \text{𓂏}$ '“chief” and $\text{𓂏} \text{𓂏} \text{𓂏} \text{𓂏} \text{𓂏} \text{𓂏}$ '“builder” are attested in Coptic only in their absolute state (εκωτ and xo(ι)c respectively), while the Egyptian forms discussed here are likely in the construct state, as they are clearly the first elements of genitival constructions. As discussed below, a direct comparison is therefore not possible, as the forms may be different.

It thus appears that the group q^e can be used to represent both plain final stressed *back* vowels, and final *back* vowels followed by some form of glide or etymological glottal stop. Two parallel scenarios can be put forward to explain this situation. A first possibility is that the Egyptians did not conceptualise such final glides and glottal stops as full consonants, and therefore they perceived final stressed *back* vowel with and without them as equivalent, at least from a writing perspective. The second possibility, instead, is that the phonotactics of Egyptian strictly required final stressed syllables to be closed, and words that did not comply to this rule were automatically extended with such a coda. Such codas were then indicated with the group q^e , at least in Period 3. It seems to me that the first scenario is more likely, but I do not think that, for now, the evidence available is conclusive.

Another word which is relevant for the current discussion is $\text{𓂏} \text{𓂏} \text{𓂏} \text{𓂏} \text{𓂏} \text{𓂏}$ = “storm-cloud”, “storm”, no. 10 in the Onomasticon of Amenope. A semi-reduplicated form $\text{𓂏} \text{𓂏} \text{𓂏}$ also exists (see attestations in WB and TLA), and survives in Coptic as κλοολε, *kl'oʔla* = “cloud”. The first, short form is well attested in Egyptian in various periods, and from the comparison of such variants its vocalisation can be safely reconstructed as $*qvr'a:$ > $*qvr'o:$. The stressed final vowel is clearly long and therefore the final syllable probably open, because the shift from *non-back* to *back* vowel seems to have taken place between Period 1 and 2 (see below for the relevant evidence). By contrast, on the basis of Coptic, the vocalisation of the long form can be safely reconstructed as $*qvr'aʔrv(?)$ > $*qvr'oʔrv(?)$ – with r = Coptic λ. A few intriguing observations stem from these two forms and from their comparison. First, it appears that the basic root of the word was $\sqrt{q-r-j}$, with a final weak consonant, as demonstrated by the early attestations of the short form spelled with a final $-j$ (e.g. Middle Kingdom $\text{𓂏} \text{𓂏} \text{𓂏} \text{𓂏}$ – see WB and TLA), and by the Coptic reflex of the longer form, where such weak consonant both survives in the middle of the word as a glottal stop and is implied at the end by the final $-e$. It is thus clear that the longer form originated from a partial reduplication of the root according to a pattern $\sqrt{c_1-c_2-c_3} > c_1vc_2vc_3c_2vc_3$, that is $\sqrt{q-r-j} > qvrvjrvj$. The stress falls in both forms on the second vowel, which can be reconstructed either as a short or as a long /a/. This identity in the quality of the vowel strongly supports the validity of these reconstructions.

Moreover, as said, the vowel of the short form is long, which suggests that the final syllable was open. This, in turn, indicates that at some point the final weak consonant

must have completely disappeared,⁶⁴ thus triggering the lengthening of the final vowel. This process must have taken place both at a time when the phonotactic rules *stressed close syllable* => *short vowel* and *stressed open syllable* => *open vowel* were still actively operating in the language and before the New Kingdom, as the New Kingdom spellings record the expected development of a long vowel.

This is a crucial observation, for multiple reasons. First of all, these attestations show once again that the group 𓆑 can be used to mark a final stressed long *back* vowel, and this not only in loanwords, but also in native words. This, in turn, is worthy of attention, because according to most of the current models, it should not have been possible to have a final stressed open syllable in final position in New Kingdom and pre-New Kingdom Egyptian.⁶⁵ For instance, forms like 𓂏𓆑 *hr'i:* = “endive” and 𓂏𓆑 *kl'e:* = possibly “strengthen” are usually reconstructed as **hvr'i:jvj* and **qvn'i:/u:jvj* respectively (see e.g. Osing 1976, 102, 193), with a never-attested⁶⁶ sequence of weak consonants and glides at their end to prevent the stressed open syllable to be in final position.

The forms discussed here, however, show that there must have been a period before the New Kingdom when such limitation was not valid any more and when open syllables with long vowels could indeed emerge in final position as the result of the fall of a final weak consonant.

As a result, this suggests that the same 𓂏𓆑 *hr'i:* and 𓂏𓆑 *kl'e:* may rather be interpreted as the outcome of a diachronic phenomenon in which the final vowel got lengthened *after* the disappearance of the final weak consonant, rather than being long *before* it, because of the presence of an additional syllable. These developments, therefore, can be reconstructed as follow: **hvr'ij* > **hvr'i* > **hvr'i:* > 𓂏𓆑 *hr'i:* and **qvn'ij* > **qvn'iu* > **qvn'i:/u:* > 𓂏𓆑 *kl'e:*.

The postulation of such a lengthening of the final stressed vowel after the disappearance of a final weak consonant provides an elegant alternative to the current glide-rich models, at least in the case of those forms displaying a final long vowel in open syllable.

§12.2 The group 𓆑 – Attestations in the Onomasticon of Amenope

Here below all the attestations of the final group 𓆑 in the Onomasticon of Amenope are presented and singularly discussed.

64 I would say either by being dropped or by being assimilated to the preceding vowel.

65 See e.g. Loprieno 1995, 37, 40.

66 And rather clumsy, I would say.

• WORDS FULLY SPELLED IN GROUP WRITING

eU-JU

| Spellings attested in the Onomasticon of Amenope (Period 3) | | |
|---|---|---|
| groom, squire | mAr.rU'U' \downarrow mArU' | *mvr'u: — |
| Diachronic spellings | | |
| Period 1 | Period 1 | Period 1 |
| *mvr'u:(?) | mArU' mArU' | mAr(r)U mArU?A/0 mArU' |
| P.Cairo 58054 v8 | P.Mayer A v11.8; EHT 1 (P.An. D) 1.8 and elsewhere; EHT 2 (P.Koller = P.Berlin 3043 = LEM 11) 1.2 and elsewhere | Gloss. Gol. 3.11 (AEO I no. 203) |

See also HoSW 132–3.173.

This word is usually interpreted as a loanword from Semitic (Hoch 1994, 132–4, no. 173) and it is compared with Akk. *mur'u* = “some kind of official” and Ugr. (pl.) *mrū* = *mur-ū* = “member of a group or class”, “chief groom (?)”, which in turn may be of foreign (Hurrian?) origin.⁶⁷

The final stressed vowel of this word must have been /u:/, because this is the only vowel that consistently remains a *back* vowel, spelled with *w = U*, in all three periods. This reconstruction is in agreement with the Semitic evidence.

Two of the spellings attested in Period 2 are worthy of attention. The use of u in mArU' is unique, and somehow surprising. If it is not just a mere mistake of the scribe, it may have been used either to mark a geminated pronunciation of the /r/ or perhaps to explicitly

67 Hoch 1994, 132–3, no. 173 compares also Arb. *ʔimruʔu* = “man”; Old Arm. *m-r-ʔ* = “lord”, “sir”, but the connection is not clear. Both DULAT 571–2 and CAD 10 228–9 consider the Ugaritic and Akkadian words as possible borrowings.

indicate that the following group ḳ^{e} had to be read rU and not Ur . The final group ḳ^{e} in the spelling $\text{ḳ}^{\text{e}}\text{ḳ}^{\text{e}}\text{ḳ}^{\text{e}}\text{ḳ}^{\text{e}}\text{ḳ}^{\text{e}}$, which I read as $mArU$. $rA/\theta = mArU\theta A/\theta$, may suggest the presence of a pronounced glottal stop (or glide?) after the final *back* vowel. This would agree with the Semitic prototype of this word, which indeed had a /ʔ/ as its third and last consonant.

| | | | | |
|-------------|---|-------------------------|----------------------------------|--|
| merchant(s) | $\text{ḳ}^{\text{e}}\text{ḳ}^{\text{e}}\text{ḳ}^{\text{e}}\text{ḳ}^{\text{e}}\text{ḳ}^{\text{e}}$ mkr' | mAkrU'U' ↓ mAkrU' | *mvk(v)r'U' | — |
| — | — | — | *mvk(v)r'U' | $\text{ḳ}^{\text{e}}\text{ḳ}^{\text{e}}\text{ḳ}^{\text{e}}\text{ḳ}^{\text{e}}\text{ḳ}^{\text{e}}$, mAkrU' |
| — | — | — | Gloss. Gol. 3.12 (AEO I no. 212) | |

The word $\text{ḳ}^{\text{e}}\text{ḳ}^{\text{e}}\text{ḳ}^{\text{e}}\text{ḳ}^{\text{e}}\text{ḳ}^{\text{e}}$ is attested only in the Onomasticon. It is usually interpreted as a Semitic loanword, related with Akk. sg. *mākiru* – pl. *mākirū* = “trader(s)”, Heb. sg. *moḳer* – pl. *mōḳrīm* = “vendor(s)”, as well as Punic *mkr* = “trader”; Old. South Arb. *mkr(m)* = “trader(s)” and Ugaritic *mkr(m)* = “trader”.

The Egyptian form seems to be plural, as indicated by the classifiers ḳ^{e} . Its vocalisation matches that of the plural of the Akkadian form, and the lack of any trace of a North-West-Semitic *-m/-n* plural marker supports this interpretation. This observation is interesting, from a socio-linguistic point of view, and may reflect the status of *lingua franca* that Akkadian enjoyed in the context of diplomatic and economic exchanges in the region during the Late Bronze Age.

| | | | | |
|------------|--|-----------------------|---------------------------------|---|
| prison (?) | $\text{ḳ}^{\text{e}}\text{ḳ}^{\text{e}}\text{ḳ}^{\text{e}}\text{ḳ}^{\text{e}}\text{ḳ}^{\text{e}}$ kr' | kArU'U' ↓ kArU' | *kvr'U' | — |
| — | — | — | *kvr'U' | $\text{ḳ}^{\text{e}}\text{ḳ}^{\text{e}}\text{ḳ}^{\text{e}}\text{ḳ}^{\text{e}}\text{ḳ}^{\text{e}}$, kArU' |
| — | — | — | Gloss. Gol. 6.2 (AEO I no. 451) | |

The word $\text{ḳ}^{\text{e}}\text{ḳ}^{\text{e}}\text{ḳ}^{\text{e}}\text{ḳ}^{\text{e}}\text{ḳ}^{\text{e}}$ is attested only in the Onomasticon. Hoch 1994, 328, no. 474 compares it with Heb. *ḳēlēʔ* = “prison”, “confinement” and with the related root $\text{ḳ}^{\text{e}}\text{ḳ}^{\text{e}}\text{ḳ}^{\text{e}}$ attested in Akkadian, Arabic, Aramaic, Ge'ez, Syriac and Ugaritic with the meaning of “to guard”, “to restrain”. The vocalisation of the Egyptian word does not match any attested Semitic form. The presence in Egyptian of a stressed final *back* vowel

In Middle Egyptian, the word was consistently written with a final -ʔ, which at the time was consonantal and which may be related with the *q*e of some of the spellings listed here. This may suggest that a glide, or possibly an extra syllable, was present at least until Period 2. Such extra syllable would justify the length of the vowel /u:/.
 —————

| | | | | |
|------------|---|--------------------------|----------------------------------|------|
| an officer | | sA.k0.U' ↓ sAkU' | *svk' o:/u: | ———— |
| — | — | *svk' o:/u: sAkU | *svk' o:/u: sAkU' | — |
| — | — | LEM 10 9.5 and elsewhere | Gloss. Gol. 3.10 (AEO I no. 198) | — |

According to Hoch (1994, 268–9, no. 381), this word may be related with the Semitic root *ʕš-k-y* = “to look”, “to watch”, although no direct prototype or precise parallel can be identified. As discussed elsewhere (Kilani 2017a, 201, see also here below II.33 in Appendix A), the group *ʕ* is likely to stand for *sU/Us*. The final stressed *back* vowel was likely /o:/ or /u:/, because the attested examples indicate the presence of a *back* vowel also in Period 2.

| | | | | |
|-----------|---|--|---------------------------------|-------|
| plasterer | | qA.d0.U' ↓ qAdU' | *qvđ' o:/u: | ———— |
| — | — | *qvđ' o:/u: qAdAy qAdU' qAdU' | *qvđ' o:/u: | qAdU' |
| — | — | P.Turin 2071/224 + 1960 2.7; O.Cairo 2.5605 5 and elsewhere; O.DeM 330 1 and elsewhere | Gloss. Gol. 3.7 (AEO I no. 182) | — |

Multiple attestations of this word exist in Period 2, and their spellings usually indicate the presence of a final *back* vowel. The only exception is (P.Turin 2071/224 + 1960 II, 7 = KRI VI, 637–8), which seems to point to a pronunciation with a *non-back* vowel. I do not know how to explain this form, and I wonder if it is just a mistake of the scribe, possibly influenced by the related word = *qAdA* “gypsum” (Hoch 1994, 307–8, no. 442), which is usually written without a final *back* vowel. The final stressed *back* vowel was likely /o:/

or /u:/, because of the spellings with *back* vowel in Period 2. The word $\Delta\aleph\aleph\aleph\aleph\aleph = qAdA$ “gypsum” is likely a Semitic loanword related with Akk. *gaššu*, Arb. *jīšš*, Arm. *geš*, Heb. *geš*, all meaning “plaster”, “gypsum”. By contrast, Hoch thinks that the word $\Delta\aleph\aleph\aleph\aleph\aleph =$ “plasterer” may be an Egyptian formation derived from such Semitic loanword.

| | | | | | |
|-----------------------|--|---|---|---|---|
| some part of animals? | $\Delta\aleph\aleph\aleph\aleph\aleph$ d' | $\Delta\aleph\aleph\aleph\aleph\aleph$ d0.U' | $\Delta\aleph\aleph\aleph\aleph\aleph$ dU' | $\Delta\aleph\aleph\aleph\aleph\aleph$ *d' o:/u: | — |
| — | — | d' o:/u: | $\Delta\aleph\aleph\aleph\aleph\aleph$ dU' | d' o:/u: | $\Delta\aleph\aleph\aleph\aleph\aleph$ dU' |
| — | — | P.Berlin 10462 (see AEO I no. 596) | | Gloss. Gol. 7.11 (AEO I no. 596) | |

The word appears as part of the expression $\Delta\aleph\aleph\aleph\aleph\aleph$, and probably refers to some part of the body (of animals?). The spelling with *U* from Period 2 suggests that the final vowel was either /o:/ or /u:/.

jn-jU

| | | | | | |
|------------|---|--|---|--|---|
| sweetmeats | $\Delta\aleph\aleph\aleph\aleph\aleph$ hn' | $\Delta\aleph\aleph\aleph\aleph\aleph$ hA.(j)n-U' | $\Delta\aleph\aleph\aleph\aleph\aleph$ hAnU' | $\Delta\aleph\aleph\aleph\aleph\aleph$ *hvn' o(ʔ/j) (?) | — |
| — | — | *hvn' aʔ/jy(ə) | $\Delta\aleph\aleph\aleph\aleph\aleph$ h-n-ʔ/jAy | *hvn' o(ʔ/j) | $\Delta\aleph\aleph\aleph\aleph\aleph$ hAnU' |
| — | — | KRI V 130.1 and elsewhere | | Gloss. Gol. 3.1, 7.3–4 (AEO I no. 149, I 555) | |

All the attested forms seem to be plural. $\Delta\aleph\aleph\aleph\aleph\aleph$ appears twice in the Onomasticon, once as an independent entry (no. 555) and once as part of the expression $\Delta\aleph\aleph\aleph\aleph\aleph$ = “maker of sweetmeats” (no. 149). The word is attested also in offering lists from Medinet Habu, where it is spelled without any *back* vowel. This may suggest, as implied in the reconstruction offered here, that the *back* vowel emerged only in Period 3, as a result of the /a/ > /o/ shift. In fact, if the vowel were /u:/ or /o:/, it should have been marked with *U* already in Period 2. This is however just a tentative suggestion and should be taken with due caution, both because the Period 2 attestations are not spelled in full group writing and because they come from monumental inscriptions, and therefore they may reflect different orthographic conventions.

| lion | ʕ $m(ʕ)$ | $m(-ʔ).U'$ ↓ $m(-ʔ)U'$ | $*m'o:ʔj$ | MOYI mu:j |
|--|---|---------------------------------|--|--------------|
| Singular | | | | |
| $*m'a:ʔj$ | $m(-ʔ)-$ $m(-ʔ)-y$ $m(-ʔ)-$ | $*m'o:ʔj$ | $m(-ʔ)U'$ $m(-ʔ)U'$ $m(-ʔ)(U')$ $m(-ʔ)-$ $m(-ʔ)U'$ | $m(-ʔ)U'$ |
| Urk IV 184.7; DZA 23.679.890; DZA 23.680.430 and elsewhere | LES 4 14.7; P.Leiden 345r G 2.7 and elsewhere; PdT 120.10; DZA 23.680.420 and elsewhere; DZA 23.680.200 and elsewhere | Gloss. Gol. 5.6 (AEO I no. 383) | | |
| Plural | | | | |
| $*m'a:ʔvw$ | $m(-ʔ)-w$ | $*m'o:ww(ʔ)$ | $m(-ʔ)U'$ | — |
| T.Cam. 1 15 and elsewhere | EHT 1 (P.An. I) 19.2 and elsewhere | — | | |

Cpt.: CrCD 160b; ČeCED 79; VyDELIC 109; WeKH 88

In the Onomasticon of Amenope, the word is attested in the toponym ⲙⲓⲛⲓⲛⲓⲛⲓ .

The Coptic form allows to reconstruct the vocalisation of this word in the three periods as $*m'a:ʔ$ - $*m'o:ʔ$ - $*m'o:$ respectively, where $ʔ$ stands for either a glide $-j$ or a glottal stop $-ʔ$ developing into a glide. The attested spellings agree with these reconstructions, and support the conclusions about that the group ʕ suggested above. By contrast, reconciling these forms with earlier forms is less straightforward. In Middle Egyptian the word was usually spelled ⲙⲓⲛⲓⲛⲓⲛⲓ , which suggests a disyllabic word $*m v:ʔj$. If this is correct, one may suggest a development $*m v:ʔj > *m v:ʔ > *m v:j > *m v:j$, that is characterised by the fall of the final syllable and by the consequent shift $-ʔ > -j$. This is the interpretation followed for instance by Vycichl (1984, 109). Alternatively, a metathesis may have taken place, thus resulting in the development $*m v:ʔj > *m v:jʔ > *m v:j$.

The ḳ^e attested in the plural forms may be consonantal, rather than being a marker of a *back* vowel, as a plural $\text{ḳ}^e\text{m}^e\text{w}^e$ is attested in Coptic (CrCD 160b).

| herdsman | $\text{ḳ}^e\text{m}^e\text{w}^e$ mjn' | m.j.n.U' ↓ m-j-nU' | *mvjn' u:w | MANHY mān' e:w |
|---|--|--------------------------|---|---|
| Singular | | | | |
| *mvjn' u:w(ə) | $\text{ḳ}^e\text{m}^e\text{w}^e$ $\text{ḳ}^e\text{m}^e\text{w}^e$ | m-j-n0-U m-j-nU | *mvjn' u:w(ə) $\text{ḳ}^e\text{m}^e\text{w}^e$ $\text{ḳ}^e\text{m}^e\text{w}^e$ $\text{ḳ}^e\text{m}^e\text{w}^e$ $\text{ḳ}^e\text{m}^e\text{w}^e$ $\text{ḳ}^e\text{m}^e\text{w}^e$ | m-j-nU' m-j-n(U') m-j-n(U') m-j-n0-U m-j-nU |
| RAD 3 1.5; P.Berlin 9785 2 and elsewhere | | | P.Turin 1953/PdT 135.7 and elsewhere; P.Turin 1895+2006/PdT 156.7 and elsewhere; P.Mayer A r2.3 and elsewhere; LES 3 7.3; LES 3 8.3 and elsewhere | Gloss. Gol. 3.1 (AEO I no. 152, 228) |
| Plural | | | | |
| ? | $\text{ḳ}^e\text{m}^e\text{w}^e$, $\text{ḳ}^e\text{m}^e\text{w}^e$ | m-j-nUy m-j-nU | ? | — |
| Both forms attested in the Abydos Decree of Seti I at Nauri (pl. 40 21; pl. 41 57 in Griffith 1927) and elsewhere | | | P.Leiden I 344 r9.2 | — |

Cpt.: CrCD 173b; ĆeCED 84; VyDELc 115–6; WeKH 94

This word appears twice in the Onomasticon, both times as an independent entry (no. 152 and no. 228).

The spellings of all the three periods consistently indicate the presence of a stressed *back* vowel, which can therefore be reconstructed as /u:/. This word can thus be vocalised as *mvjn' u:w(ə).

Two main forms are attested in Coptic. The first and most common one is 𐩠𐩢𐩠𐩪 < *m 'i/ujnv or the like.⁶⁹ The second one, 𐩠𐩢𐩠𐩪 (S), 𐩠𐩢𐩠𐩪 (B), is rarer. A plural 𐩠𐩢𐩠𐩪 (S), 𐩠𐩢𐩠𐩪 (B) is also attested. The singular form 𐩠𐩢𐩠𐩪 (S), 𐩠𐩢𐩠𐩪 (B) has often been interpreted as a compound noun from *mjn* 'šw.t = “herdsman of cattle” (Crum 173b implicitly, Černý 84). Vycichl (1984, 115–6), however, disagreed with such interpretation, arguing that šw.t should have resulted in -šwε, not -šy; he thus wondered if this form could derive from a plural used as singular/collective.

I think that Coptic 𐩠𐩢𐩠𐩪 (S) is the form underlying the Egyptian spellings, as its New Kingdom vocalisation can be reconstructed as *myn 'u:w(ə). As for its origin, I wonder if it is an independent alternative form, as implicitly suggested by Vycichl, or if it is rather the result of a (pre-New-Kingdom) lexicalisation of the expression *mjn* 'šw.t, which resulted in a new, etymologically obscure form. I find the first solution somehow easier, but I do not think the evidence available is conclusive.

At any rate, the form 𐩠𐩢𐩠𐩪 < *m 'i/ujnv could be a secondary form or an innovation that become common only later.

The Period I plural 𐩠𐩢𐩠𐩪, which displays a 𐩐, may suggest a slightly different vocalic pattern, perhaps something like *mv(jv)mw 'u:y/ w(ə). This form may be at the origin of the Coptic plural 𐩠𐩢𐩠𐩪 (S), 𐩠𐩢𐩠𐩪 (B), which would then have a different origin from the singular 𐩠𐩢𐩠𐩪 (S), 𐩠𐩢𐩠𐩪 (B). The difference in the Bohairic forms may support this interpretation. This suggestion is however very speculative, as the evidence is not clear enough to be conclusive.

Vycichl (1984, 116) mentioned also a personal name *ma-ni-e* from cuneiform sources contemporary to the 18th Dynasty, which he analysed as a possible variant of this word with the stress on the last syllable. Such a vocalisation, however, matches neither the Egyptian nor the Coptic attested forms, and I actually doubt it is related at all.

| | | | | |
|-----------------------------|---------------|-------------|--------|---------------------------------|
| time, return of the year | 𐩠𐩢𐩠𐩪 n(r)' | ↓ n(r)U' | *n'u:j | 𐩠𐩢𐩠𐩪 (B) n'ε:/εj |
| — | — | — | — | *n'u:j |
| — | — | — | — | 𐩠𐩢𐩠𐩪 n(r)U' |
| — | — | — | — | Gloss. Gol. 1.12 (AEO I no. 57) |

Cpt.: CrCD 219a; ČeCED 105; VyDEL 141; WeKH 120

69 Perhaps through a metathesis *m 'i/ujnv > *m 'i/ujjv?

Words without direct Coptic reflexes

| | | $\text{ⲥ} \cdot \text{ⲉ} \cdot \text{Ⲙ}$ \downarrow $\text{ⲥ} \cdot \text{ⲉ} \cdot \text{Ⲙ}$ | $\text{ⲥ} \cdot \text{ⲉ} \cdot \text{Ⲙ}$ \downarrow $\text{ⲥ} \cdot \text{ⲉ} \cdot \text{Ⲙ}$ | $\text{ⲥ} \cdot \text{ⲉ} \cdot \text{Ⲙ}$ \downarrow $\text{ⲥ} \cdot \text{ⲉ} \cdot \text{Ⲙ}$ |
|---|--|--|---|--|
| boy | | | | |
| Singular | | | | |
| $\text{ⲥ} \cdot \text{ⲉ} \cdot \text{Ⲙ}$ u:(o): | $\text{ⲥ} \cdot \text{ⲉ} \cdot \text{Ⲙ}$ | $\text{ⲥ} \cdot \text{ⲉ} \cdot \text{Ⲙ}$ u:(o): | $\text{ⲥ} \cdot \text{ⲉ} \cdot \text{Ⲙ}$ $\text{ⲥ} \cdot \text{ⲉ} \cdot \text{Ⲙ}$ $\text{ⲥ} \cdot \text{ⲉ} \cdot \text{Ⲙ}$ $\text{ⲥ} \cdot \text{ⲉ} \cdot \text{Ⲙ}$ /y | $\text{ⲥ} \cdot \text{ⲉ} \cdot \text{Ⲙ}$ u:(o): |
| P.An. IX v2 | | LEM 6 8.6 and elsewhere; LEM 7 31 and elsewhere; P.Leiden 371 v10; LEM 12 v2.1 and elsewhere | | Gloss. Gol. 4.11 (AEO I no. 301) |
| Plural | | | | |
| $\text{ⲥ} \cdot \text{ⲉ} \cdot \text{Ⲙ}$ u: | $\text{ⲥ} \cdot \text{ⲉ} \cdot \text{Ⲙ}$ | $\text{ⲥ} \cdot \text{ⲉ} \cdot \text{Ⲙ}$ u: | $\text{ⲥ} \cdot \text{ⲉ} \cdot \text{Ⲙ}$ $\text{ⲥ} \cdot \text{ⲉ} \cdot \text{Ⲙ}$ | — |
| P.Leiden I 350 5.8 | | O.Berlin P 10627 10 and elsewhere; PdT 116 10, 11 and elsewhere | | — |

The word is widespread in Late Egyptian sources, but it does not have any direct Coptic descendant. Its consonants are usually read as $\text{ⲥ} \cdot \text{ⲉ} \cdot \text{Ⲙ}$, following the conventions of Middle Egyptian. I think however that the variants $\text{ⲥ} \cdot \text{ⲉ} \cdot \text{Ⲙ}$ and $\text{ⲥ} \cdot \text{ⲉ} \cdot \text{Ⲙ}$ indicate that its actual reading was $\text{ⲥ} \cdot \text{ⲉ} \cdot \text{Ⲙ}$, and the sequence $\text{ⲥ} \cdot \text{ⲉ} \cdot \text{Ⲙ}$ should be read as a group where only the ⲉ is pronounced, while the Ⲙ is silent. This interpretation is supported by the fact that the verb $\text{ⲥ} \cdot \text{ⲉ} \cdot \text{Ⲙ}$ evolves into Coptic $\text{ⲉ} \cdot \text{Ⲙ}$; where the ⲉ was not pronounced anymore. The possible vocalic value of this group, if any, is hard to determine on the basis of this single word.⁷⁰ Here again, the group ⲉ indicates the presence of a final stressed *back* vowel. Its use in both Period 2 and Period 3 hints at either a vowel /o:/ or a vowel /u:/. The presence of a ⲉ in the plural in Period 1 favours a vowel /u:/, but the fact that only spellings without it are attested in the singular may suggest that the singular had a different vocalic pattern than the plural.

70 There are a few possibilities: a *non-back* vowel *A* from a Period 1 pronunciation $\text{ⲥ} \cdot \text{ⲉ} \cdot \text{Ⲙ}$; or a *back* vowel *U* from a later pronunciation $\text{ⲥ} \cdot \text{ⲉ} \cdot \text{Ⲙ}$? Or both depending on the period? Or none?

Words in construct state

| | | | | |
|----------------|---|-----------------------------|---|-----------|
| maker, builder | \aleph \aleph \aleph \aleph \aleph \aleph jqd' | j-q-d/tU' ↓ j-q-d/tU' | * \aleph vq(a)d'U' | — |
| — | — | — | * \aleph vq(a)d'U' | j-q-d/tU' |
| — | — | — | Gloss. Gol. 3.7, 3.7, 3.8 (AEO I no. 184, 185, 186) | — |

Cpt.: CrCD 122b–123a; ČeCED 65; VyDELc 40; WeKH 71

This word appears three times in the Onomasticon, in the following expressions: \aleph \aleph \aleph \aleph \aleph \aleph = “maker of little (vessels?)” (no. 184), \aleph \aleph \aleph \aleph \aleph \aleph = “maker of *hn*-vessels” (no. 185), and \aleph \aleph \aleph \aleph \aleph \aleph = “builder of walls” (no. 186). I could not find any previous attestation of this word in construct state.

See below for discussion.

| | | | | |
|-----------|--|---------------------|---|-------|
| commander | \aleph \aleph \aleph \aleph \aleph \aleph ts' < tsy | t-sU' ↓ t-sU' | *tvs'U' | — |
| — | — | — | *tvs'U' | t-sU' |
| — | — | — | Gloss. Gol. 3.15–6 (AEO I no. 234, 235) | — |

Cpt.: CrCD 787b–788a; ČeCED 320; VyDELc 324–5; WeKH 416

In the Onomasticon, this word appears in the title \aleph \aleph \aleph \aleph \aleph \aleph = “commander of the archers”, which is repeated twice (nos 234–5).

In previous periods, this title is usually spelled \aleph \aleph \aleph and the like, which obviously does not provide any information about its vocalisation. See here below for discussion.

§12.3 Words in construct state – Some observations

$\text{ḳ} \text{ḳ} \text{ḳ}$ = “commander” and $\text{ḳ} \text{ḳ} \text{ḳ} \text{ḳ}$ = “builder” have direct descendants in Coptic, namely xo(i)c and ekwɾ . However, the syntactical state of the Egyptian forms underlying these spellings is different from that attested for their Coptic descendants, the first being in the *construct state* and the latter being attested only in the *absolute state*. The difference between these two states is essentially prosodic: on the one hand words in the *absolute state* are either autonomous prosodic units or core elements of larger prosodic sequences, while on the other hand words in *construct state* are prosodically subordinate elements within larger prosodic units, which usually consist of simple direct genitival constructions or direct genitival constructions lexicalised as compound nouns. The expressions $\text{ḳ} \text{ḳ} \text{ḳ} \text{ḳ}$ $\text{ḳ} \text{ḳ} \text{ḳ}$ $\text{ḳ} \text{ḳ} \text{ḳ}$, “maker of little (vessels?)” (no. 184), $\text{ḳ} \text{ḳ} \text{ḳ} \text{ḳ}$ $\text{ḳ} \text{ḳ} \text{ḳ}$ $\text{ḳ} \text{ḳ} \text{ḳ}$ = “maker of *hm*-vessels” (no. 185), $\text{ḳ} \text{ḳ} \text{ḳ} \text{ḳ}$ $\text{ḳ} \text{ḳ} \text{ḳ}$ $\text{ḳ} \text{ḳ} \text{ḳ}$ = “builder of walls” (no. 186), and $\text{ḳ} \text{ḳ} \text{ḳ} \text{ḳ}$ $\text{ḳ} \text{ḳ} \text{ḳ}$ $\text{ḳ} \text{ḳ} \text{ḳ}$ = “commander of the archers” (nos 234–5) discussed here (see below) may belong to the latter case, both because they are listed as entries in a lexical list, which may suggest they were perceived as single lexical units by the Egyptians, and because simple direct genitival constructions are relatively rare in Late Egyptian.

The prosodic profile of a word in *absolute state* depends exclusively on morphological features (e.g. number or gender) of the word itself, while the prosodic profile of a word in *construct state* may and do change due to its subordinate relation with other prosodic elements of the sentence. Simple direct genitival constructions and compound nouns, and therefore the *construct state*, were common features in Middle Egyptian, but they are rare and restricted to a limited number of words in Coptic. The *construct state* is therefore attested in Coptic only for a few words, and it is generally characterised by the absence of any stressed syllable and therefore by the reduction of all its vowels (e.g. Cpt. $\text{m}\text{ḳ}\text{ḳ}\text{ḳ}\text{ḳ}$ = *māntr'o:mā* < **m'anvt* + **r'a:mvt* – see Loprieno 1995, 57). Moreover, scanty evidence from cuneiform transcriptions seems to suggest that the *construct state* prosodic patterns of simple genitival constructions and of compound names may have been different, in ways that are far from being completely understood (Loprieno 1995, 56–7). Therefore, it is generally impossible to use Coptic forms in their *absolute states* to reconstruct the vocalisation and stress patterns of *construct states* in previous periods.

For these reasons, it is not possible to compare the forms $\text{ḳ} \text{ḳ} \text{ḳ}$ and $\text{ḳ} \text{ḳ} \text{ḳ} \text{ḳ}$, in *construct state*, with their Coptic descendant, attested only in *absolute state*. What is possible to do, instead, is to use the group writing spelling of these words to infer some information about the vocalisation of the *construct state* of these words in Period 3.

On the basis of the Coptic forms, the vocalisation of the *absolute state* in Period 3 can be reconstructed as xo(i)c < * $\text{ḳ}'\text{oys}(\partial)$ and ekwɾ < * $\text{ḳ}'\text{vq}'\text{o:d}\partial$, which reflect the earlier vocalic pattern $c'\text{occv}(y/w)$ < $c'\text{accv}(y/w)$ and $\text{cvc}'\text{o:cv}(w/y)$ < $\text{cvc}'\text{a:cv}(w/y)$ respectively. The group writing spelling of these words can instead be interpreted as * $\text{ḳ}'\text{v}(\text{y})\text{s}'\text{U}$ and * $\text{ḳ}'\text{vq}(\text{v})\text{d}'\text{U}$. It thus appears that in contrast with the *absolute state*, in the *construct state* the last syllable was stressed and characterised by a *back* vowel.

In order to determine the precise nature of such stressed *back* vowels, two considerations have to be taken into account. As mentioned above, according to the standard models, final

stressed syllables in native words should be closed, and therefore their vowels should be short. One may wonder if such rule, if it existed at all (see above), was relevant also for the first elements of compound nouns, because in those contexts, those syllables would not be prosodically final any more. In such cases, it may have been possible, at least in theory, that an originally unstressed final open syllable⁷¹ became stressed in the *construct state*, and could manifest itself as stressed open syllable, because although it was still the final syllable of the first morpheme, it was not prosodically final any more.

This considered, three different vocalisations can be suggested. If their stressed final syllables were closed and their corresponding vowel were short, then these words must have been vocalised **ṭv(yv)s 'o'* and **ṭvq(v)d 'o'*, because /o/ was the only short *back* vowel available in Period 3.

By contrast, if the final syllable was open, then these *U* may have stood for either a vowel /o:/ or a vowel /u:/, and therefore $\text{ṭ} \text{v} \text{e} \text{ṣ} \text{ḥ}$ may have been vocalised as **ṭv(yv)s 'o:'* or **ṭv(yv)s 'u:'*, and $\text{ṭ} \text{v} \text{q} \text{ḥ} \text{ḥ}$ as **ṭvq(v)d 'o:'* or **ṭvq(v)d 'u:'*.

On the basis of these words, it can thus be tentatively suggested that the *construct state* of the vocalic patterns *c'occv(y/w) < c'accv(y/w)* and *cvc 'o:cv(w/y) < cvc 'a:cv(w/y)* was characterised by the movement of the stress to the last syllable and therefore had the form *cvc(v)c 'o' ~ cvc(v)c 'o: ~ cvc(v)c 'u: < cvc(v)c 'a' ~ cvc(v)c 'a: ~ cvc(v)c 'u:* or the like. Further evidence is needed to determine whether this behaviour is specific of these two words, or it is rather characteristic of these (and other?) vocalic patterns in general.

71 Whose possible existence has been variously suggested – see e.g. Loprieno 1995, 36, 62–3.

§13 The case of *ym* - εΙΟΜ

As it appears from the previous paragraphs and from Appendix A here below, the spelling of the word *ym* - εΙΟΜ appears to be generally regular, with a stressed *non-back* vowel for Periods 1 and 2 (when the word expected vocalisation was **yam* - see Appendix I.1, II.2) and with a *back* vowel in Period 3 (when the word expected vocalisation was **yom* - see III.2).

There are, however, a few additional attestations which appear to be related with this word and which seem to be somehow irregular. Two in particular need attention.

1) – Astarte Papyrus

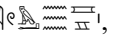
The first of such attestations, spelled , comes from the Papyrus Astarte (pBN 202 1.2, 1.x+6, 1.x+13, 2.x+2, 2.x+6, 2.x+11, 2.x+18, 17.y – see Collombert and Coulon 2000), dating to the reign of Amenhotep II. Since the text comes from Period 1, if the word was the same as *ym* = εΙΟΜ, one would expect a spelling implying a *non-back* vowel. However, the form clearly suggest a *back* vowel. This becomes even more problematic if we considered that at the time, not only the shift /a/ > /o/, but also the shift /a:/ > /o:/ had not occurred yet.

The first aspect to consider is the nature of the text (see Collombert and Coulon 2000 for discussion). The papyrus of Astarte is an Egyptian text which records a mythical tale of evident North-West-Semitic origins related with the storm god Ba'al, identified in the text with Seth. The story may have had various episodes, as it was the case for the Ugaritic cycle of Ba'al, but only very small fragments of the papyrus survive, and only an episode of a fight between the storm god Ba'al/Seth and the sea god Yam can be identified. The language and style of the papyrus is also worthy of attention: although it is written in proper Late Egyptian, the text contains multiple unusual expressions that have perfect parallels in North-West Semitic sources.⁷²

With this in mind, the first thing to note is that the word  of P.Astarte does not refer just to the “sea” as an extension of water, in general, but rather it refers to the sea as a divine entity. Such deity clearly corresponds to Yammu, the Cananite god of the sea, whose name is indeed identical with the word for “sea” in North-West-Semitic languages. This distinction in the meaning of the word is crucial for two reasons. First, being this word a personal name of a specific god, it may have to be considered as lexically distinct from the word *ym* - εΙΟΜ. Second, this Egyptian form could be based on, and could thus reflect, the pronunciation of this divine name in a specific North-West-Semitic tradition, rather than being a transcription of the contemporary pronunciation of the general noun *ym* - εΙΟΜ = “sea”. This possibility becomes even more likely if the narrative preserved in the papyrus was based on a North-West-Semitic original.

72 The similarities are so remarkable that it has even been suggested (Gaster 1952) that the text may be a translation of a North-West-Semitic original, possibly realised in a cultic environment – a possibility that I indeed find worth of attention.

2)  – P.Anastasi I

The second exceptional attestation is spelled  and appears in P.Anastasi I 21.1, which dates to Period 2. In this case, judging from the context, the word does seem to mean just “sea”:

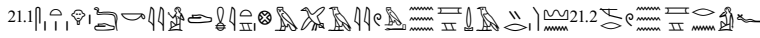
21.1. 

“They tell of another city in the sea, Tyre-the-port is its name.”

The spelling clearly suggests the presence of a *back* vowel, but in Period 2 a *non-back* vowel would be expected. Once again, the first aspect to consider is the nature of the text in which this attestation appears. P.Anastasi I preserves a copy of the so-called *Letter of Hori*, a text relatively widespread in the New Kingdom and likely used for didactic purposes (see Gardiner 1911, *passim*; Fischer-Elfert 1992, *passim*, Allen in Hallo and Younger 1997–2002, III.9). One of the characteristic features of this text is the abundance of North-West-Semitic words.⁷³ Moreover, it is also worth noticing that the word  appears in a passage that specifically describes the city of Tyre, which is located in Lebanon and was one of the main Phoenician centres during the Iron Age.

Besides the two attestations just discussed, a few occasional comparable forms spelled with a *back* vowel exist also in other documents.⁷⁴ Such forms may be all related, and they may share the same origin as those of P.Astarte or P.Anastasi I, or may have been influenced by comparable forms.

In this case, one may suggest that the word  of the Astarte papyrus had to be read as **yum(mv)~*yu:mV* in Egyptian,⁷⁵ while in the case of Pap. Anastasi I a reading **yo:mV* could also be possible. This form may reflect a North-West-Semitic prototype **yum(mu) ~ *yūm(mu) ~ *yōm(mu)* which, however, does not seem to be attested: the available North-West-Semitic evidence seems to point to a contemporary prototype **yam(mu)*, with a *non-back* vowel /a/, not with a *back* vowel /u(:)~/~/o:/.⁷⁶ These exceptional spellings are, therefore, difficult to explain. If they are not mere mistakes of the Egyptian scribes, these Egyptian spellings may reflect an otherwise unattested secondary North-West-Semitic post-Cananite shift form **yōm(mu) ~ *yōm(u)*, deriving from a pre-Cananite shift prototype ***yām(mu) ~ **yām(u)*, with a long vowel. If this is the case, a main Egyptian form **yam(mV) < N-W-Sem. *yam(mu)* and a secondary, less common

73 Including a whole North-West-Semitic sentence appearing in P.An. I 23.5. It is possible that one of the purposes of this text was to familiarise the Egyptian students to words in foreign languages that may have been useful in their future career as scribes, hence the high concentration of North-West-Semitic words and loanwords.

74 In particular P.Harris I and P.Turin 21 and 22 (Pleyte and Rossi 1869) – see digitalised slips for *ym* in the online database of the Berlin *Wörterbuch der ägyptischen Sprache*.

75 With *U* = /u(:)/ as at the time this was the only *back* vowel available in the language.

76 The Phoenician form may have been */yom/*, but the Phoenician development of short /a/ into /o/ is usually considered to be later than the Egyptian texts discussed here, and therefore can hardly explain these spellings.

form **yum(mu)* ~ **yūm(mu)* ~ **yōm(mu)* may have coexisted at least until Period 3, when the vocalic shift /a/ > /o/ made them indistinguishable in writing.

§14 Conclusions

It is clear that the interpretative model presented here still needs to be refined. However, it is the first system that allows to explain all the forms of a methodologically sound and solid corpus, and does so by attributing only one vocalic value to each group – although it does allow for two possible readings *CVVC*. The validity of the system can be argued both on synchronic and diachronic ground, and it is strongly supported by the results of the statistical analysis described in §9.

Some aspects, however, still need to be clarified and, hopefully, explained. For instance, it is still unclear if monoliteral signs were functionally different from *c+ʔ* groups. The evidence analysed here seems to suggest that they were equivalent and no difference existed between them. However, further studies could help to support this conclusion, or could lead to alternative interpretations.

The same stands true also for the question of the sign 𐀀 . I think that the evidence presented in this book convincingly shows that the sign 𐀀 was not used as a vocalic marker and illustrates some of its other specific functions. Nevertheless, in some contexts the reasons for the presence of 𐀀 still remain unclear, and would need further investigation. A systematic reanalysis of Semitic loans attested in group writing, whether they survive in Coptic or not, may help in clarifying these aspects.

The interpretative model presented here, and in general a more reliable understanding of the functioning of the vocalisation of group writing, opens numerous doors for further research. First and foremost, this new interpretation provides an innovative powerful tool to explore the vocalisation of the Egyptian language and its evolution through the Egyptian texts themselves, thus providing a considerable amount of fresh data. Its potential is not only limited to forms attested in Coptic, as those forming the corpus used in this study, but it extends to any word written in group writing, even to those known only from Late Egyptian sources. This is particularly true for those terms that are attested over more than one period: by combining the data from the different attestations, it would be possible to guess not only if the word had a *back* or *non-back* vowel, but also the specific nature of such vowel. For instance, if a word is attested with a *non-back* vowel in Period 1 and with a *back* vowel in Period 2, we can assume that such vowel was an /a:/ that turned into an /o:/, as this is the only vocalic change that took place at that time that could explain such a difference in spelling. By contrast, for instance, a word displaying a *non-back* vowel in Period 2 and a *back* vowel in Period 3 would imply the presence of an /a/ turning into /o/, while a word displaying a *back* vowel in Period 1, 2 and 3 would imply the presence of a vowel /u:/ or /u/, as those are the only *back* vowels that remain stable across the three periods.

The possibility of recognising the nature of the stressed vowel would also provide information about the syllabic structure of such word, as the presence of an /a:/ > /o:/ in Period 1–2 would imply the presence of an open syllable, and therefore of a specific syllabic structure for the whole word. By contrast, the presence of an /a/ > /o/ would

imply the presence of a closed syllable in Period 1-2, and therefore an altogether different syllabic pattern.⁷⁷

More in general, to be able of reconstructing the vocalisation also for words which are not attested in Coptic or in other external sources⁷⁸ provides a whole new range of possibilities to deepen our understanding of various linguistic aspects of the Egyptian language. For instance, the vocalisation of verbal forms could be studied. For the reasons explained in §3.1, no verb was included in the corpus used in this book. Nevertheless, various verbs are indeed attested in group writing, and their study could shed new light on crucial grammatical issues.

The vocalisation inferred from group writing spellings could also be used to date the texts in which they appear. It is clear that if the group writing spelling of a word in a given text suggests a stressed /o:/, while that of another word in the same text suggests a stressed vowel /a/, then the that text should likely be dated⁷⁹ to Period 2, because only then the vowels /o:/ and /a/ could coexist.

Similarly, the appearance of Semitic loanwords attested in group writing could be used to estimate when they have entered Egyptian, for instance by correlating their vocalisation with the so-called Canaanite vocalic shift. This in turn may help in better defining the chronological and sociocultural frames of the interactions that brought these words into Egyptian.

More in general, this new reading of group writing words could certainly bring new crucial data also for the study of (North-West-)Semitic languages and dialects, for a period for which only few scanty traces are otherwise available.

Finally, this new interpretation of group writing could also be applied to historical sources, such as the topographical lists, not only to obtain a better reading of the names themselves, but also to verify the identifications suggested so far, which until now have usually been based only on the consonantal skeleton of these names.

77 This, for instance, could be used to dismiss doubtful Coptic etymology. For instance Černý (1976, 340) suggested to link Coptic ⲥⲟϣϣ “safflower” “cardamom” with Egyptian *kt* “some herb or flower”. This etymology was however very doubtful and was not endorsed by any other scholar. Now it can also be rejected on the bases of the Egyptian evidence itself. The Egyptian word *kt* is in fact spelled $\text{𓆎} \text{𓆏} \text{𓆐} = kAt(A)$ in Period 1, $\text{𓆎} \text{𓆏} \text{𓆑} = kAt(A)$ in Period 2, and $\text{𓆎} \text{𓆏} \text{𓆑} \text{𓆒} = kUt(A)$ in Period 3. This sequence *A-A-U* clearly indicates the presence of a stressed short /a/ shifting to /o/. The Coptic form, however, requires a long /a:/, which would have shifted to /o:/ already in Period 2. Therefore, the Egyptian and Coptic forms cannot be directly related.

78 Such as Akkadian transcriptions.

79 Either in its composition or in its redaction – this is actually an aspect that indeed need to be further researched.

References

- Abraham, K., and M. Sokoloff. 2012. "Aramaic Loanwords in Akkadian – A Reassessment of the Proposals." *Archiv für Orientforschung* 52: 1–92.
- Albright, W.F. 1934. *The Vocalisation of the Egyptian Syllabic Orthography*. American oriental series 5. New Haven, Conn: American Oriental Society.
- Allen, J.P. 2010. *Middle Egyptian: an Introduction to the Language and Culture of Hieroglyphs*. 2nd ed., . Cambridge: Cambridge University Press.
- 2013. *The Ancient Egyptian Language: an Historical Study*. Cambridge: Cambridge University Press.
- Baxter, W.H. 2014. *Old Chinese: a new reconstruction*. New York: Oxford University Press.
- Bisang, W. 2006. "Linguistic Areas, Language Contact and Typology: Some Implications from the Case of Ethiopia as a Linguistic Area." In *Linguistic Areas: Convergence in Historical and Typological Perspective*, edited by Yaron Matras, April M. S. McMahon, and Nigel Vincent, 75–98. Basingstoke: Palgrave Macmillan. <http://www.loc.gov/catdir/enhancements/fy0634/2005056583-t.html>.
- Bomhard, A.R. 1984. *Toward Proto-Nostratic: a New Approach to the Comparison of Proto-Indo-European and Proto-Afroasiatic*. Amsterdam studies in the theory and history of linguistic science. Series IV, Current issues in linguistic theory ; v. 27. Amsterdam; Philadelphia: Benjamins.
- Bordreuil, P., and D. Pardee. 2010. *Manuel d'ougaritique*. Gauthier Manuels. Paris: P. Geuthner.
- Caminos, R.A. 1958. "A Fragmentary Duplicate of Papyrus Anastasi I in the Turin Museum." *The Journal of Egyptian Archaeology* 44: 3–4. doi:10.2307/3855056.
- 1977. *A Tale of Woe: from a Hieratic Papyrus in the A. S. Pushkin Museum of Fine Arts in Moscow*. Oxford: Griffith Institute.
- Černý, J. 1939. *Late Ramesside Letters*. Bibliotheca Aegyptiaca 9. Bruxelles: Édition de la Fondation égyptologique reine Élisabeth.
- 1943. "The Origin of the Name of the Month Tybi." *Annales du Service des Antiquités de l'Égypte* 43: 173–181.
- 1976. *Coptic Etymological Dictionary*. Cambridge: Cambridge University Press.
- Černý, J., and A.H.S. Gardiner. 1957. *Hieratic Ostraca*. Vol. 1. Oxford: Printed for the Griffith Institute at the University Press by Charles Batey.
- Chen, S.-F. 2000. "A Study of Sanskrit Loanwords in Chinese." *Tsing Hua Journal of Chinese Studies* 30 3: 375–426.
- Collombert, P., and L. Coulon. 2000. "Les dieux contre la mer: le début du "papyrus d'Astarté" (pBN 202)." *Bulletin de l'Institut Français d'Archéologie Orientale* 100: 193–242.
- Crum, W.E. 1939. *A Coptic Dictionary*. Oxford: Clarendon Press.
- Diakonoff, I.M. 1975. "On Root Structure in Proto-Semitic." In *Hamito-Semitic: proceedings of a colloquium held by the Historical Section of the Linguistics Association, Great Britain at the School of Oriental and African Studies, University of London, on*

- the 18th, 19th and 20th of March 1970*, edited by James Bynon and Theodora Bynon, 133–153. *Janua linguarum. Series practica* 200. The Hague: Mouton.
- Edel, E. 1966. *Die Ortsnamenlisten aus dem Totentempel Amenophis III.* Bonner biblische Beiträge 25. Bonn: Hanstein.
- Erman, A., and H. Grapow. 1926–1963. *Wörterbuch der ägyptischen Sprache.* 7 vols. Leipzig: Hinrichs.
- Fischer-Elfert, H.-W. 1992. *Die satirische Streitschrift des Papyrus Anastasi I.: Textzusammenstellung.* 2nd edition. Wiesbaden: Harrassowitz.
- Fishman, G.S. 1995. *Monte Carlo: Concepts, Algorithms, and Applications.* Springer series in operations research. New York: Springer.
- Fox, J. 2003. *Semitic Noun Patterns.* Harvard Semitic studies 52. Winona Lake: Eisenbrauns.
- Gardiner, A.H.S. 1911. *Egyptian Hieratic Texts. Series 1, Literary Texts of the New Kingdom.* Leipzig: Hinrichs.
- 1916. “The Defeat of the Hyksos by Kamōse: The Carnarvon Tablet, No. I.” *The Journal of Egyptian Archaeology* 3 2/3: 95–110. doi:10.2307/3853741.
- 1932. *Late-Egyptian Stories.* Bruxelles: Fondation égyptologique reine Elisabeth.
- 1937. *Late-Egyptian Miscellanies.* Bibliotheca Aegyptiaca 7. Bruxelles: Édition de la Fondation égyptologique reine Elisabeth.
- 1947. *Ancient Egyptian Onomastica.* Oxford: Oxford University Press.
- 1948. *Ramesseid Administrative Documents.* London: Published on behalf of the Griffith Institute, Ashmolean Museum, Oxford by Oxford University Press.
- Gaster, T.H. 1952. “The Egyptian ‘Story of Astarte’ and the Ugaritic Poem of Baal.” *Bibliotheca Orientalis* 9 3/4: 82–85.
- Gauthier, H. 1925–1931. *Dictionnaire des noms géographiques contenus dans les textes hiéroglyphiques.* 7 vols. Le Caire: Institut français d’archéologie orientale pour la Société royale de géographie d’Égypte.
- Gilboa, A., and I. Sharon. 2016. “The Assyrian Kāru at Du’ru/Dor.” In *The Provincial Archaeology of the Assyrian Empire*, edited by John MacGinnis, Dirk Wicke, Tina Greenfield, and Adam Stone, 241–252. McDonald Institute for Archaeological Research.
- Griffith, F.L. 1927. “The Abydos Decree of Seti I at Nauri.” *The Journal of Egyptian Archaeology* 13 3/4: 193–208.
- Hallo, W.W., and K.L. Younger, eds. 1997–2002. *The Context of Scripture: Canonical Compositions, Monumental Inscriptions, and Archival Documents from the Biblical World.* Leiden: Brill.
- Helck, W. 1971. *Die Beziehungen Ägyptens zu Vorderasien im 3. und 2. Jahrtausend v. Chr.* 2nd edition. Ägyptologische Abhandlungen 5. Wiesbaden: Harrassowitz.
- Hoch, J.E. 1994. “Semitic Words in Egyptian Texts of the New Kingdom and Third Intermediate Period.” . Doctoral Thesis, Princeton: Princeton University Press.
- Janssen, J.J. 1975. *Commodity Prices from the Ramessid Period: an Economic study of the Village of Necropolis Workmen at Thebes.* Leiden: Brill.

- Junge, F. 2005. *Late Egyptian Grammar: an Introduction*. 2nd edition. Griffith Institute Publications. Oxford: Griffith Institute.
- Kilani, M. 2017a. “The Function of Final w in Nouns and Adjectives in the Autography of Selected Late Egyptian Texts.” *Zeitschrift für Ägyptische Sprache und Altertumskunde* 144. doi:10.1515/zaes-2017-0012.
- 2017b. “Byblos in the Late Bronze Age: Interactions between the Levantine and Egyptian Worlds.” . Doctoral Thesis, Oxford: Oxford University.
- Kitchen, K.A. 1975–1990. *Ramesside Inscriptions: Historical and Biographical*. Oxford: Blackwell.
- Laisney, V.P.-M. 2007. *L'Enseignement d'Aménémopé*. Studia Pohl. Series maior 19. Roma: Pontificio Istituto biblico.
- Lesko, L.H. 2002–2004. *A Dictionary of Late Egyptian*. Ed. Barbara S. Lesko. 2nd edition. Providence: B.C. Scribe.
- Loprieno, A. 1995. *Ancient Egyptian: a Linguistic Introduction*. Cambridge: Cambridge University Press.
- Osing, J. 1976. *Die Nominalbildung des Ägyptischen*. Mainz; Rhein: Von Zabern.
- Peet, T.E. 1977. *The Great Tomb-robberies of the Twentieth Egyptian Dynasty*. Hildesheim: Olms.
- Peust, C. 1999. *Egyptian phonology: an introduction to the phonology of a dead language*. Monographien zur ägyptischen Sprache 2. Göttingen: Peust & Gutschmidt.
- Pleyte, W., and F. Rossi. 1869. *Papyrus de Turin*. Leide: Brill.
- Rachewiltz, I. de. 2004. *The Secret History of the Mongols: a Mongolian Epic Chronicle of the Thirteenth Century*. Brill's Inner Asian Library 7. Leiden: Brill.
- Schneider, T. 1992. *Asiatische Personennamen in ägyptischen Quellen des Neuen Reichs*. Orbis biblicus et orientalis 114. Göttingen; Freiburg (Schweiz): Vandenhoeck & Ruprecht; Universitätsverlag.
- Sethe, K. 1916. “Der Ursprung des Alphabets.” *Nachrichten von der Gesellschaft der Wissenschaften zu Göttingen* 2: 88–161.
- Sethe, K., and W. Helck. 1906–1958. *Urkunden der 18. Dynastie*. Urkunden des ägyptischen Altertums IV. Leipzig: Hinrichs.
- Vycichl, W. 1984. *Dictionnaire étymologique de la langue copte*. Leuven: Peeters.
- Walsem, R. van. 1982. “Month-names and Feasts at Deir el-Medina.” In , edited by Rob J. Demarée and Jac J. Janssen, 215–244. *Egyptologische uitgaven* 1. Leiden: Nederlands Instvoor het Nabije Oosten.
- Ward, W.A. 1996. “A New Look at Semitic Personal Names and Loanwords in Egyptian.” *Chronique d'Égypte* 71 141: 17–47. doi:10.1484/J.CDE.2.309003.
- Wegner, I. 2007. *Einführung in die hurritische Sprache*. 2nd ed. Wiesbaden: Harrassowitz.
- Westendorf, W. 1965. *Koptisches Handwörterbuch*. Heidelberg: Winter.
- Zeidler, J. 1991. “A New Approach to the Late Egyptian ‘Syllabic Orthography.’” In *Sesto congresso internazionale di Egittologia = sixth international congress of Egyptology = sixième congrès international d'Égyptologie = sechster internationaler Ägyptologen-Kongress*, 2:579–590. Turin: IAE.

- Zhivlov, M. 2014. “Studies in Uralic vocalism III.” *Journal of Language Relationship* 12: 113–148.

Appendix A

Abbreviations

Languages

| | |
|------|---|
| Akk. | Akkadian |
| Arb. | Arabic |
| Arm. | Aramaic |
| Eth. | Ethiopic – mainly Ge'ez or Proto Ethiopic |
| Cpt. | Coptic |
| Eg. | Egyptian |
| Heb. | Hebrew |
| Sem. | Semitic (as a linguistic group, or as Common/Proto-Semitic) |
| Syr. | Syriac |
| Ug. | Ugaritic |

Egyptian Dictionaries and Lexical studies

| | |
|------|--|
| HoSW | <i>Semitic Words in Egyptian Texts</i> , Hoch, 1994 |
| LeLE | <i>A Dictionary of Late Egyptian</i> , Lesko, 2002–2004 |
| TLA | <i>Thesaurus Linguae Aegyptiae</i> , http://aew.bbaw.de/tla/index.html |
| WB | <i>Wörterbuch der ägyptischen Sprache</i> , Erman, Grapow, 1926–1963 |

Coptic Dictionaries

| | |
|-------|---|
| ČeCED | <i>Coptic Etymological Dictionary</i> , Černý, 1976 |
| CrCD | <i>A Coptic Dictionary</i> , Crum, 1939 |
| CAD | Chicago Assyrian Dictionary, Gelb, etc, 1956–2011 |
| DULA | <i>A Dictionary of the Ugaritic Language in the Alphabetic Tradition</i> , Olmo Lete, Sanmartín, 2003 |
| VyDEL | <i>Dictionnaire étymologique de la langue copte</i> , Vycichl, 1984 |
| WeKH | <i>Koptisches Handwörterbuch</i> , Westendorf, 1965 |

Other sources

Note: for questions of space, only basic references are given in the appendix for the Egyptian attestations. For the specific publications, see the bibliographic references in HoSW *Semitic Words in Egyptian Texts* Hoch 1994, in LeLE *A Dictionary of Late Egyptian* Lesko 2002–2004 and in the online database and digitised slips of the Berlin *Wörterbuch der ägyptischen Sprache – Thesaurus Linguae Aegyptiae* (<http://aew.bbaw.de/tla/> : last visited 5.11.2017)

| | |
|---------------|--|
| AEO I | <i>Ancient Egyptian Onomastica</i> Gardiner 1947 |
| BM EA | British Museum Catalogue |
| Gloss. Gol. | Glossary Golenischeff (see AEO I) |
| C.DAI | <i>Caminos, Duplicate of Papyrus Anastasi I</i> Caminos 1958 |
| EHT | <i>Egyptian Hieratic Texts</i> Gardiner 1911 |
| H.O. | <i>Hieratic Ostraca</i> Černý and Gardiner 1957 |
| P.Ch. Beatty | Papyri Chester Beatty = HPBM 3 |
| HPBM | <i>Hieratic Papyri in the British Museum</i> (series with various authors) |
| Inscr. Hamm | Inscriptions Wadi Hammamat |
| JEA | <i>Journal of Egyptian Archaeology</i> |
| KRI | <i>Kitchen Ramesside Inscriptions</i> Kitchen 1975–1990 |
| LEM | <i>Late-Egyptian Miscellanies</i> Gardiner 1937 |
| LES | <i>Late-Egyptian Stories</i> Gardiner 1932 |
| LLR | London Leather Roll = BM EA 10379 |
| LRL | <i>Late Ramesside Letters</i> Černý 1939 |
| O.Berlin | Ostraca Berlin |
| O.BM EA | Ostraca British Museum |
| O.Cairo | Ostraca Cairo |
| O.DeM | Ostraca Deir el-Medina |
| O.Gard. | Ostraca Gardiner |
| O.IFAO | Ostraca Institut français d'archéologie orientale |
| O.Petrie | Ostraca Petrie |
| O.ROM | Ostraca Royal Ontario Museum, Toronto |
| O.Turin | Ostraca Turin |
| O.Vienna Aeg. | Ostraca Vienna, Egyptian collection |
| P.Abbott | Papyrus Abbott = BM EA 10221 |
| P.An. | Papyri Anastasi |
| P.Berlin | Papyri Berlin |
| P.BM EA | Papyri British Museum |
| P.Boulaq | Papyri Boulaq |
| P.Cairo | Papyri Cairo |
| P.DeM | Papyri Deir el-Medina |
| PdT | <i>Papyrus de Turin</i> Pleyte and Rossi 1869 |
| P.Ebers | Papyrus Ebers |
| P.Harris I | Papyrus Harris I = BM EA 9999 |
| P.Harris 500 | Papyrus Harris 500 = BM EA 10060 |
| P.Hood I | Papyrus Hood I = BM EA 10202 |
| P.Leiden | Papyri Leiden |
| P.Mallet | Papyrus Mallet = Louvre 1050 Louvre E 11006 |
| P.Mayer | Papyrus Mayer |
| P.Push. 127 | Papyrus Pushkin Museum 127 |
| P.Sallier | Papyrus Sallier |
| P.Salt 124 | Papyrus Salt 124 = BM EA 10055 |

| | |
|--------------|--|
| P.Turin | Papyri Turin |
| RAD | Ramesside Administrative Documents Gardiner 1948 |
| RdE | <i>Revue d'Égyptologie</i> |
| T.Carn. 1 | Tablet Carnarvon 1 (Gardiner 1916) |
| TR | <i>The Great Tomb-robberies of the Twentieth Egyptian Dynasty</i> Peet 1977 |
| Trismegistos | http://www.trismegistos.org (last visited 5.11.2017) |
| Univ.Board | University College Writing Board = AEO I 64-8 |
| Urk. IV | <i>Urkunden der 18. Dynastie</i> Sethe and Helck 1906–1958 |

Attestations

Period I

| | | | | | |
|-----|-------|--|-------------------------|--------------|------------------|
| I.1 | a jar |  jkn | jA.kU.nA ↓ jAkUnA | *ʔvk'a:/o:nv | AKΩNE āk'o:nə |
|-----|-------|--|-------------------------|--------------|------------------|

Eg.: Urk. IV 665.16 = HoSW 42.36; Urk. IV 717.16 = HoSW 42.36; Urk. IV 722.3 = HoSW 42.36; Urk. IV 731.11 () = HoSW 42.36

Cpt.: WeKH 484

Sem.: *ʔagga(:)n(nv) – cf. Akk. *agannu*; Arb. *ʔijjāna*; Warka Arm. *ag-gan-nu*, *ag-ga-nu*; Syr. *ʔaggānā*, all referring to some kind of vessel.

Notes: the form *a-ku-nu* appearing in an Amarna letter is likely a transcription of the Egyptian form, rather than of Semitic prototype, both because of the *k* instead of *g* and because the word appears in a list of vessels sent from Egypt. If so, the spelling *ku* would confirm once again the early shift /a(:)/ > /o:/ in Egyptian (see above §4.5.1).

It is worth noticing that a variant  is also attested (LeLE i.50 H.O. 87v5). This form is clearly spelled according to the *w*-orthography and has to be read as *jkn-w = jkwn*. This spelling is important because it confirms the *back* nature of the stressed vowel and therefore confirms the reading of the form spelled in group writing.

Finally, two variants εκΩNE and εσΩNE are also attested in Sahidic.

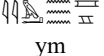
| | | | | | |
|-----|-----|--|------------------------|-------|--------------|
| I.2 | sea |  ym | yA.m(A) ↓ yAm(A) | *y'am | εΙΟΜ j'om |
|-----|-----|--|------------------------|-------|--------------|

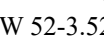
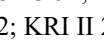
Eg.: P.Leiden I 350 1.11 = HoSW 52-3.52; Ramses II Tanis stele (Yoyotte Kemi 10 pl. VI 15) () = HoSW 52-3.52; KRI II 230.10 () = LeLE i.28 = HoSW 52-3.52

Cpt.: CrCD 77a; ČeCED 46; VyDELIC 63; WeKH 49

Sem.: *yam(mv) – cf. Amorrite *yammum*; Arb. *yam*; Arm. *yamm(ā)*; Heb. *yam*, all “sea”

Notes: see discussion §13.

| | | | | | |
|-----|---------------------|--|---------------------------|--|-----------------------|
| I.3 | branch of date-palm |  bšyt ₁ | bA.ʕA.y0.ə ↓ bAʕAyə | *bvʕ'i:/u:y(wv) > *bv'y'i:/u:ʕ(wv) | βΑΕΗΗ (pl.) bāj'e: |
|-----|---------------------|--|---------------------------|--|-----------------------|

Eg.: P.Harris 500r 2.4

Cpt.: CrCD 27b; ČeCED 20; VyDELIC 24; WeKH 19

Notes: The Egyptian form is a plural/collective, and so is the Coptic βαειη Vycichl 1984, 24. The corresponding Coptic singular is βα / βαε.

| | | | | |
|-----|--------|--|-----------|-----------------------------|
| | | | bA.yr0.yA | q/φ/βορι (B/B/S) |
| I.4 | a fish |  bry | ↓ | *b'ar(yv) |
| | | | bAr(yA) | βαρε (S) b'orə b'o:rə |

Eg.: P.Leiden I 350 3v.4 = LeLE i.136

Cpt.: CrCD 42a; ČeCED 25; VyDELIC 30; WeKH 26

Notes: According to Vycichl 1984, 25, the Coptic forms with -o- are originally plural. They could also just alternative singular forms. This latter option is supported by the Egyptian spelling (also in Period 2 and 3), as the use of  implies that the first syllable was closed, and therefore had a short vowel.

| | | | | |
|-----|--------------|---|-------|----------------|
| | | | bA.sA | |
| I.5 | pail, bucket |  bs | ↓ | *b'i:/u:sv |
| | | | bAsA | βΗσε b'e:sə |

H.O. 65 2v.3 = LeLE i.139

Cpt.: CrCD 44b; ČeCED 27; VyDELIC 31–2; WeKH 27

Notes: see Janssen 1975, 206

| | | | | |
|-----|----------------|--|---------|----------------------------|
| | | | m0.Uyṛh | μερ(ε)Ί |
| I.6 | spear, javelin |  mrḥ | ↓ | *m'i/urḥv < Sem. *murḥv |
| | | | mUrḥ | μερḥΊ m'erəḥ mər'e:h |

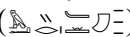
Eg.: LEM 11 1.5 = LeLE i.194 = HoSW 138.179; LEM 5 17.1 = LeLE i.194 = HoSW 138.179; KRI II 789.9 () = HoSW 138.179

Sem.: *rumḥ(v) – cf. Arb. *rumḥ*; Arm. *rumḥā*; Eth. *ramḥ*; Heb. *rōmah*; Syr. *rumḥā*, all “spear”

Cpt.: CrCD 184a; ČeCED 90; VyDELIC 121; WeKH 101

Notes: the form attested in KRI II 789.9 may be a plural. The Coptic form μερḥΊ suggest the existence of an alternative form *mvr'i:/u:hv, which also may in fact have originally been a plural.

For the metathesis in the Egyptian form see Ug. *mrḥ* and see above, §6.

| | | | | |
|-----|---------|--|-----------------|----------------------|
| | | | mA.yr0.k0.Ub.tA | |
| I.7 | chariot |  mrkbt | ↓ | *mvrk'a/obtv |
| | | | mArkUbt(A) | βΡσοοΥΤ bərki'owt |

Eg.: H.O. 75 v.6 = HoSW 145-6.189
 Cpt.: CrCD 44b; ČeCED 27; VyDELIC 31; WeKH 27
 Sem.: **markabt(v)* – cf. Akk. *narkabtu*; Arb. *markaba*; Arm. *markabtā*; Heb. *merkāḇā*; Syr. *markabtā*; Ug. *markabt-*, all “chariot”

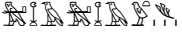
| | | | | |
|-----|-----------------------|---|------------------------|---|
| | | | mA.h0.mA.h.wi0.ə | |
| I.8 | flowers (purslane) |  mhḥmḥwt _i | ↓ | *mvḥm' aḥwv *mε2mo2γe *mehm' ohwə |
| | | | mAhmAhw _i ə | |

Eg.: P.Harris 500r 7.3 = LeLE i.201
 Cpt.: CrCD 211b; ČeCED 99; VyDELIC 131; WeKH 112
 Notes: the presence of  and the plural strokes suggests that the Egyptian form is plural. No distinct plural form is attested in Coptic, but a plural **mε2mo2γe* - **mehm' ohwə* can be assumed from sg. SB *mε2mo2γe*, by analogy with sg. πe - pl. πηγe “sky”-“skies” (CrCD 259a).

| | | | | |
|-----|------------|---|---------------|---|
| | | | mA.k0.tA.r(A) | |
| I.9 | stronghold |  mkt _r | ↓ | *mvkt'a(:)l(v) μεστο/ωλ (B/S) məkt' o/o:l |
| | | | mAktAr(A) | |

Eg.: KRI I 10.1 = LeLE i.212 = HoSW 169.224
 Cpt.: CrCD 214b; ČeCED 102; VyDELIC 132; WeKH 114
 Sem.: **mi/agda:l(v)* – cf. Heb. *migdāl* (n.loc. *migdōl*); Arm. *mi/agdlā* all “tower”, “fortress”; see also Akk. n.loc. *magdali*

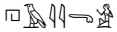

| | | | | |
|------|---------|---|-------|--------------------------|
| | | | hA.y0 | |
| I.10 | husband |  hy | ↓ | *h'i/uy 2Δ1 h'aj |
| | | | hAy | |

Eg.: P.Harris 500r 7.8,8.4; P.Leiden I 348 v11.1
 Cpt.: CrCD 636b; ČeCED 269; VyDELIC 290; WeKH 357

| | | | | |
|------|--------|---|-------|--------------------------|
| | | | h0.Up | |
| I.11 | law(s) |  hp | ↓ | *h'i/up 2Δπ h'ap |
| | | | hUp | |

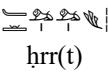
Eg.: KRI I 55.9 = LeLE i.287; KRI I 76.1 = LeLE i.287 ()
 Cpt.: CrCD 693b–5a; ČeCED 289; VyDELIC 306; WeKH 381
 Notes: this form may actually be spelled according to the *w*-orthography, rather than in group writing.

| | | | | | |
|------|--------|---|----------|-------------|----------------|
| I.12 | flower |  | hU.rU.Ur | *hvr'i:u:rv | ⲫⲣⲉ hr'e:rə |
| | | | ↓ | | |

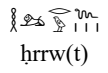

Eg.: Harris 500 7.7-8 (); KRI I 109.16 (); DZA 27.265.150 - Luxor Hypostyle hall, Amenhotep III ()

Cpt.: CrCD 704a; ĀeCED 294; VyDELc 310; WeKH 388

| | | | | | |
|------|--------------|---|--------------|--------------|------------------------|
| I.13 | beetle, worm |  | hA.rU.r0.w1A | *hvl'i:u:lwv | *ⲫⲗⲉⲗⲉ (A) hāl'elwə |
| | | | ↓ | | |

Eg.: P.Ebers 19.16

Cpt.: CrCD 669a; ĀeCED 279; VyDELc 297; WeKH 366

Notes: as in the case of  above (I.8), the presence of  and the plural strokes suggests that the Egyptian form is plural. No distinct plural form is attested in Coptic, but a plural *ⲫⲗⲉⲗⲉ - *hāl'elwə can be assumed from sg. A ⲫⲗⲗⲗ, by analogy with sg. ⲡⲉ - pl. ⲡⲛⲉ “sky”-“skies” (CrCD 259a).

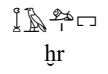
| | | | | | |
|------|--------------------------|---|-------|------------------------------|------------|
| I.14 | road, street, quarter |  | h0.Ur | *h'i:u:rv < Sem. *hur(rv) | ⲫⲣ h'ir |
| | | | ↓ | | |

Eg.: KRI 273.9 = HoSW 247.343

Cpt.: CrCD 696b; ĀeCED 291; VyDELc 307; WeKH 384

Sem.: *hur(ru) – cf. Akk. *hurru* “hole”, “cave”; Heb. *hōr* “hole”; see HoSW for the semantic development

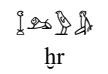
| | | | | | |
|------|--------|---|-------|--------------------------------|------------|
| I.15 | Syrian |  | h0.Ur | *h'u/ir(rv) < Sem. *hur(rv) | ⲫⲗ h'al |
| | | | ↓ | | |

Eg.: Urk. IV 743.8

Cpt.: CrCD 665a; ĀeCED 277; VyDELc 295–6; WeKH 363

Sem.: *hur(rv) – Akk. *hurru*; Heb. *hōrī* “name of a population”, ultimately from Hurrian (see Loprieno 1995, 46).

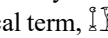
Notes: the Coptic word means “servant”, “slave”. This word is attested multiple time in all the three periods, especially in the plural, and so are adjectival forms as well as the corresponding geographical term,  = “Hurrian land”, “Syria”. However, since the Coptic form is singular, only substantives in the singular are listed in this appendix, both here and for the other periods below.

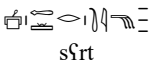
| | | | | | |
|------|------------|---|-----------------------------|-----------|---------------|
| I.16 | wool, hair |  | sA.ʕA.r0.tA ↓ sAʕArtA | *svʕ'artv | COPT s'ort |
|------|------------|---|-----------------------------|-----------|---------------|

Eg.: KRI III 500.2, 500.10-11, 502.12, 503.11-12 = LeLE ii.15 = HoSW 256.359
 Cpt.: CrCD 356b; ČeCED 162; VyDELIC 197; WeKH 195
 Sem.: *šafʕrat(v) – Akk. šārtu “hair”, “pelt”, “wool”; Arb. šafʕra “hair”; Eth. šəfərt “hair”;
 Heb. šafʕārā “hair”; Ug. šafʕartu; masculine forms are also attested in various Semitic
 languages.

Notes: Given the plural stroke, the Egyptian form may be a collective. The nature of the
 vowel, however, would not change in this period.

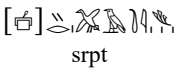
| | | | | | |
|------|-------|---|----------------------------|----------|-----------------------------|
| I.17 | lotus |  | sA.ʕr0.pA.t ↓ sArpAt | *svrp'at | CAPT/ΦO/AT (O/B) sārp'ot |
|------|-------|---|----------------------------|----------|-----------------------------|

Eg.: P.Harris 500r 2.7-8 = LeLE ii.58
 Cpt.: CrCD 356b; ČeCED 161–2; VyDELIC 196; WeKH 195
 Sem.: *sarpad(v) – cf. Heb. sirpād “some plant”, “nettle”, in turn from Middle Egyptian
 sʕpt (not in Hoch, see Vycichl 1984, 196

Notes: As pointed out by Černý 1976, 162 the Late Egyptian word is likely a borrowing
 from a Semitic language, but in turn the Semitic form is likely a borrowing from earlier
 Middle Egyptian sʕpt “lotus”. Note that the Semitic form preserves the final Egyptian /t/
 as /d/ and the /r/ suggests that the word was borrowed from Egyptian when ʕ was still
 pronounced as a trill. At the same time, as observed by Vycichl 1984, 196, the preservation
 of the final /t/ and the pronunciation with /r/ in the Late Egyptian (and the Coptic) word
 indicate that this form must have been a borrowing from Semitic, because if it were a
 direct descendant of Middle Egyptian sʕpt the final /t/ should have disappeared and the /ʕ/
 should have been pronounced and transcribed, as a glottal stop, not as /r/.

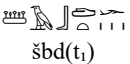
| | | | | | |
|------|--------------------|---|---------------------------|-----------------------|--|
| I.18 | staves, rods (pl.) |  | šA.bA.d0.ə ↓ šAbAdə | *švb'adv *švb'a:dv | ϣϣⲟⲩ (B) ϣϣⲟⲩ (S) šəb'otə šəb'o:t |
|------|--------------------|---|---------------------------|-----------------------|--|

Eg.: P.Harris 500r 2.3 = LeLE ii.117-8 = HoSW 276-8.397
 Cpt.: CrCD 554a; ČeCED 238; VyDELIC 258; WeKH 305
 Sem.: *šibt(v) – cf. Arm. šibṭā; Eth. šəbt; Heb. šəḇeṭ; Syr. šabṭā, all “rod”, “staff”; cf also
 Akk. šabātu “to beat”.

Notes: see §8 for discussion – Both Egyptian and Coptic forms are plural and could
 correspond to either II.34b or II.34d of Period 2.

Since in this period the prototypes of both the Coptic forms would have been pronounced with a *non-back* vowel, there is no way and no need to distinguish them.

Note that the vocalic structure of the Coptic, and therefore the Egyptian forms does not agree with any of the vocalic patterns characterising the Semitic forms.

A solution, however, may come from the regular plural of the Heb. form, which is *šəbāṭīm*. Such a form (possibly through a dialect or a variant without mimation **šəbāṭī*?) may have been at the origin or may have influenced the vocalic pattern of the Egyptian word.

| | | | | | |
|------|-------------------------|---|-------------------|-------|--------------|
| I.19 | father/mother in law |  šm | šA.m0 ↓ šAm | *š'am | ϣⲟⲙⲓ š'om |
|------|-------------------------|---|-------------------|-------|--------------|

Eg.: JEA 66.100 = LeLE ii.122

Cpt.: CrCD 564a; ČeCED 243; VyDELC 263; WeKH 314

| | | | | | |
|------|---------------|--|--------------------------|-----------|-------------------|
| I.20 | scale of fish |  šnft ₁ | šA.n0.f0.ə ↓ šAnfə | *š'i/unfv | ϣ(ε)ⲛⲑε š'enfə |
|------|---------------|--|--------------------------|-----------|-------------------|

Eg.: Hymnus an Aton, line 10 (tombs no. 1 - Huya and no. 3 - Ahmose)

Cpt.: CrCD 574a; ČeCED 247; VyDELC 267; WeKH 320

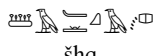
| | | | | | |
|------|------|---|-------------------------|-------------|--------------------|
| I.21 | dust |  šhq | šA.ḥU.qA ↓ šAḥUqA | *švh'i:u:qv | ϣ(ⲉ)ⲓⲉ šəh'i:kj |
|------|------|---|-------------------------|-------------|--------------------|

Eg.: HPBM3 CB 9 vB 18.10 = HoSW 267.411

Cpt.: CrCD 612b; ČeCED 263; VyDELC 277; WeKH 341

Sem.: no comparable Semitic form is attested, but according to Hoch the word is likely related with Sem. $\sqrt{\text{šhq}}$ “to grind”, “to pulverise”, see Heb. $\sqrt{\text{šhq}}$ “to pulverise (stone)”; Akk. *šēqu* “to smooth”, “to level off”; Arb. *saḥaqa* “to crush”, “to pulverise”; Arm. *šəḥaq* “to grind”, “to rub”, “to pound”; Syr. *šəḥaq* “to pulverise”. The Egyptian form may derive from a *qatīl* passive/stative particle Fox 2003, 187–96.

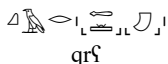

| | | | | | |
|------|--------|--|------------------------|----------------------------|----------------|
| I.22 | shield |  qrf | qA.r0.ʕA ↓ qArʕA | *q'i/ulʕv < Sem. *qilʕv | ϣ(ⲁ)ⲗ kī'al |
|------|--------|--|------------------------|----------------------------|----------------|

Eg.: KRI II 6.10 = LeLE ii.156 = HoSW 298.432

Cpt.: CrCD 806a; ČeCED 326; VyDELC 337; WeKH 448

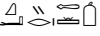
Sem.: **qilʕ(v)* – cf. Arb. *qilʕ* “sail”; Arm. *qilʕā* “curtains”, “sail”; Heb. *qelaʕ* “slingshot”; Syr. *qelaʕ* “slingshot”, “sail”; for the meaning, see Ug. *qlʕ* “shield”.

Notes: A spelling  is attested in O. Turin 57365.

KRI II 6.6 and KRI II 6.7 have two attestations which are not written in group writing, but are characterised by a final . The meaning of this final sign is puzzling, especially at the beginning of the 19th Dynasty. However, I think it can be excluded that it was a marker of vocalisation (as it was spelled with , not with  as it is usually the case in *w*-orthography), and therefore does not really concerns us here. Perhaps it was a attempt to write some form of ending (perhaps a case?) in the original Semitic language. A specific study of the monumental orthography of the period would be needed to clarify this point, but this is obviously beyond the scope of this study.

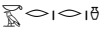
| | | | | |
|------|--------------------|--|----------|---------------------------------|
| | | | kA.rA.rA | |
| I.23 | vessel for unguent |  krr | ↓ | *kvl'a:lv κελωλ kəl'o:l |
| | | | kArArA | |

Eg.: P.Boulaq XIII frag. 11.3 = LeLE ii.176

Cpt.: CrCD 104a; ČeCED 56; VyDELC 77; WeKH 62

Notes: see BIFAO 83 (Pl.48) p.244.

| | | | | |
|------|------------|---|-------------|------------------------------------|
| | | | kU.rA.kU.rA | |
| I.24 | couch, bed |  krkr | ↓ | *kvl'ak(kvrv) κλωσ kəl'okj |
| | | | kUrAkUrA | |

Eg.: Urk. IV 667.2 = LeLE ii.117 = HoSW 333–4.486

Cpt.: CrCD 815a, var.s: κλωσ, τλ. (S); κλωσ (BF); σλ. (B); κλωσ (AA²F); δαλεσ (F); ČeCED 330; VyDELC 340; WeKH 454

Sem.: *kvlak(kv) – cf. Akk. *kalakku* “long chair”; perhaps also related with Arm. *gəliltā* “folding couch; cot” and Heb. *√gll* “turning”, “folding”

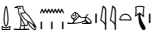
| | | | | |
|------|----------|--|----------------------|---|
| | | | ḏA.nṛU.y0.ə | |
| I.25 | scorpion |  ḏ ⁿ ryt _i | ↓ | *ḏv ⁿ r'i:u:yv κλη kl'e: |
| | | | ḏA ⁿ rUyə | |

Eg.: HPBM3 CB 7r 6.7

Cpt.: CrCD 810a; ČeCED 327; VyDELC 337; WeKH 449

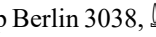
Notes: misspelled in Pap Berlin 3038, [...]. Date unsure, attributed here to Period 1 because found with administrative document of Ramses II (see: <http://sae.saw-leipzig.de/detail/dokument/papyrus-berlin-p-3038/> last visited: 3.11.2017)

| | | | | |
|------|--------------|--|----------|---------------------------------|
| | | | ḏA.n0.Uḥ | |
| I.26 | arm (of oar) |  ḏnh | ↓ | *ḏvn'a/i/uḥ χνασ jən'ah |
| | | | ḏAnAḥ | |

Eg.: KRI I 273.10 = LeLE ii.270

Cpt.: CrCD 777a; ČeCED 317; VyDELIC 329; WeKH 428

Notes: the Coptic form means “arm”, “shoulder”.

The spelling of the Egyptian form suggests an original vowel /u/, and such a vowel could indeed be the ancestor of Coptic α in front of γ . It is worth noting that a *back* vowel was also implied by a form spelled in *w*-orthography that I discussed a previous work (Kilani 2017a, 194–5). At the time, such form puzzled me, and I suggested that the *-w* may have actually been a dual ending. The group writing spelling of the form discussed here, however, clearly shows that the word was characterised by a stressed *back* vowel. This is a crucial observation as it constitutes a double validation of the *w*-orthography: on the one hand it is an internal confirmation of the presence of a *back* vowel in a word spelled with the marker *-w*, and on the other it allows to explain, and thus to eliminate, the only exception in the series of words with tonic α , which therefore appear to be always coherently spelled without the marker *-w* when they do not derive from an earlier vowel /u/ (see Kilani 2017a, 193–5).

Period 2

| | | | | | |
|------|--------------------------------|--|-------|-------------|---------------|
| II.1 | a purple dye- plant, madder | | jA.pA | *ʔvp'i:(cv) | ⲁⲡⲉⲓ ǎp'i: |
| | | | ↓ | | |
| | | | jApA | | |

Eg.: LEM 10 4.6 = LeLE i.25

Cpt.: CrCD 14a; ČeCED 11; VyDELIC 14; WeKH 10

| | | | | | |
|------|-----|--|---------|-------|--------------|
| II.2 | sea | | yA.m(A) | *y'am | ⲉⲓⲟⲙ j'om |
| | | | ↓ | | |
| | | | yAm(A) | | |

Eg.: LES I 8.9 = LeLE i.28 = HoSW 83.100; LEM 3 3.1 = HoSW 52.52; Medinet Habu 600.5,7 = HoSW 52.52 (); KRI V 91.9 = HoSW 52.52 ()

Cpt.: CrCD 77a; ČeCED 46; VyDELIC 63; WeKH 49

Sem.: see attestations in Period 1 above.

Notes: see attestations in Period 1 above.

| | | | | | |
|------|--------|--|---------------------------|---------|-----------|
| II.3 | pebble | | ʕ0.U _{n1} /ʕ(r)r | *ʕ'i/ur | ⲁⲗ 'al |
| | | | ʕU.n ₁ r0 | | |
| | | | ↓ | | |
| | | | ʕU ⁿ r | | |

| | | | | | |
|------|--------------------------------|----|--------------------|---------|-------------------|
| II.7 | young bird which cannot fly | wr | wA.yr0 ↓ wAr | *w'i/ur | {MΔ2}ογαλ w'al |
|------|--------------------------------|----|--------------------|---------|-------------------|

Eg.: H.O. 38 1v.3

Cpt.: CrCD 208a; ČeCED 98; VyDELIC 129; WeKH 110

Notes: Vycichl derives MΔ2ογαλ from Demotic *mḥwl* and Egyptian *mḥwn* “dovecote”, Černý suggests the same etymology, but in addition he analyses *mḥwn/l* as deriving from *mḥ* + *wr*, namely “nest” + “young bird”, and identify the second element *wr* with Late Egyptian .

| | | | | | |
|------|--------------|----|---------------------|---------|-------------|
| II.8 | ball of eyes | bʳ | bU.n₁r0 ↓ bUʳ | *b'i/uʳ | BΔΔ b'al |
|------|--------------|----|---------------------|---------|-------------|

Eg.: LES 4 10.4 = LeLE i.134

Cpt.: CrCD 31b; ČeCED 22; VyDELIC 27; WeKH 22

Notes: Possibly plural or dual. No different form for the plural is attested in Coptic, and it is possible that this was the case also in Late Egyptian. Alternatively, it is likely that the plural had a structure *b'i:/u:ʳv. In this case, the length of the stressed vowel would have been different, while its nature would have been the same as in the singular.

| | | | | | |
|------|--------|-----|-------------------------|---------|---|
| II.9 | a fish | bry | bA.yr0.yA ↓ bAryA | *b'aryv | Ϣ/ϣ/Ϣορτ (B/B/S) Bορτ (S) b'orə b'o:rə |
|------|--------|-----|-------------------------|---------|---|

Eg.: H.O. 35 1rII.3 (); H.O. 85 1v.13-14 (); LEM 5 15.7-8 (); LEM 3 2.7 () = LeLE i.136

Cpt.: CrCD 42a; ČeCED 25; VyDELIC 30; WeKH 26

Notes: see notes to the attestations in Period 1.

In Period 2, it is attested twice in O.Petrie 31, always with instead of , once misspelled .

According to the slip of the *Berlin Wörterbuch*, a spelling is attested in an unpublished papyrus from the Museum of Turin, which I was unable to identify. According to the slip, however, the text is related with the trial of thieves probably in connection with the Ramesside tomb robberies, and therefore it must belong to Period 2.

| | | | | | |
|-------|---------|----|--------------------|------------|-------------|
| II.10 | God Bes | bs | bA.sA ↓ bAsA | *b'i:/u:sv | BHC b'es |
|-------|---------|----|--------------------|------------|-------------|

Eg.: P.Abbott 5.17, 6.11
 Cpt.: VyDELIC 31; WeKH 27

| | | | | | |
|-------|--------------|--|-------|-----------|----------------|
| II.11 | pail, bucket | | bA.sA | *b'i/u:sv | BHCE b'e:sə |
| | | | ↓ | | |
| | | | bAsA | | |

Eg.: O.IFAO 1017 v.4-5; O.Gard. 139 3; O.Berlin 11 260.6; O.Berlin 12 652.v3
 Cpt.: CrCD 44b; ČeCED 27; VyDELIC 31–2; WeKH 27
 Notes: see Janssen 1975, 206

| | | | | | |
|-------|------------------|--|-------|-----------|-----------|
| II.12 | some fruit, malt | | bA.šA | *b'i/uʔšv | BE(ε)U |
| | | | ↓ | > | BH(H)U |
| | | | bAšA | *b'i/ušʔv | b'e:(:)?š |

Eg.: HPBM3 CB 5 r8.9
 Cpt.: CrCD 46b; ČeCED 29; VyDELIC 33; WeKH 29
 Notes: a form is also recorded in the archive of digitalised slips of the Berlin *Wörterbuch der ägyptischen Sprache* (DZA 22.932.550). The word is said to come from line 22 of a stele from the temple of Ramses III in Karnak. I was however unable to track down this attestation.

| | | | | | |
|-------|------|--|------------|-----------------------------|-------------------|
| II.13 | bean | | pU.rA(.yA) | *p'i/ur(yv) < Sem. *pu:l | φελ (B) |
| | | | ↓ | | p ^h el |
| | | | pUr(yA) | | |

Eg.: H.O. 85 1r.11 () = LeLE i.148,151 = HoSW 118.150; H.O. 29 2v.3 () = HoSW 118.150; O.Turin 57146 7 () = HoSW 118.150; H.O. 31 1vII.2,5 () = LEM 5 15.11 = LeLE i.148,151 ()
 Cpt.: CrCD 514a; ČeCED 225; VyDELIC 244; WeKH 146
 Sem.: *pu:l(u) – cf. Arb. *fūl* “ful beans”; Arm. *pōlā* “ful beans”; Heb. *pōl* “ful beans”
 Notes: the form with *y* and *jA* could be morphologically plural. This, however, would not affect the *back* nature of the first vowel.

| | | | | | |
|-------|----------------|--|---------|----------------------------|---------|
| II.14 | spear, javelin | | m0.Uʔrḥ | *m'i/urḥv < Sem. *murḥv | MEP(ε)Z |
| | | | ↓ | | m'erəḥ |
| | | | mUrḥ | | mər'e:h |



Eg.: O.BM EA 50733 + O.Petrie 30 i,2/O.Petrie 30 ii,7 (KRI VII 333.11,16) = HoSW 138.179

Cpt.: CrCD 184a; ĆeCED 90; VyDELc 121; WeKH 101

Sem.: see attestations in Period 1 above.

Notes: see attestations in Period 1 above.

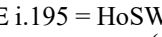
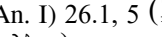
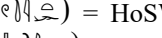
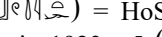
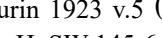
| | | | | | |
|-------|---------|---|---|---------------|----------------------|
| II.15 | chariot |  | mA. ^y r0.k0.Ub.tA ↓ mArkUbt(A) | *mvrk' a/obtv | ⲃⲣⲚⲟⲟⲩⲧ bærk' owt |
|-------|---------|---|---|---------------|----------------------|

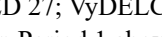
Eg.: LEM 3 6.8 = LeLE i.195 = HoSW 145-6.189; LEM 5 16.7 () = HoSW 145-6.189; EHT 1 (P.An. I) 26.1, 5 () = LeLE i.195 = HoSW 145-6.189; LEM 3 6.7 () = HoSW 145-6.189; O.Edinburg 916 r.3,5,6,8,10,12,13, v.4,6,8,10,13 () = HoSW 145-6.189; KRI IV 409.4 () = HoSW 145-6.189; P.Turin 1923 v.5 () = HoSW 145-6.189; P.Turin 1885 v.1.7 () = HoSW 145-6.189.

Cpt.: CrCD 44b; ĆeCED 27; VyDELc 31; WeKH 27

Sem.: see attestations in Period 1 above.

| | | | | | |
|-------|-------------|---|--|-----------------------------|------------------|
| II.16 | basket, box |  | mA.h ^y 0.Ur ↓ mA _h 2Ur | *mvh ₂ ' i:/u:rv | ⲙⲩⲩⲣ mæš' i:r |
|-------|-------------|---|--|-----------------------------|------------------|

Eg.: H.O. 61 3v.2 = LeLE i.202 = HoSW 151.195;

Cpt.: CrCD 206a; ĆeCED 97; VyDELc 129; WeKH 109

Sem.: no precise parallel can be identified, but Hoch suggests it may related with Sem. \sqrt{mhr} “to receive”, cf. Akk. *maḥāru* “to receive”, *namḥāru* “bowl”, “jug”.

Notes: Coptic: pot, box for incense, censer possibly also H.O. 63. 1V2 –  = KRI VI, 162,10-163,6.

Hoch mentions also an attestation in H.O. 85 1v.6, but it is a mistake: that is an attestation of *mhr* = “6th month”, not of *mhr* = “basket”, “box” (see below II.17)

| | | | | | |
|-------|-----------|---|-------------------------------------|---------------|------------------|
| II.17 | 6th month |  | mA.h0.Ur ↓ mA _h Ur | *mvh' i:/u:rv | ⲙⲩⲩⲣ mæš' i:r |
|-------|-----------|---|-------------------------------------|---------------|------------------|

Eg.: P.Cairo 86637 Cv14.6; H.O. 85 1v.6

Cpt.: CrCD 206a; ĆeCED 96; VyDELc 129; WeKH 109

Notes: Coptic /i:/ < /i:/~ /u:/ because of the following /r/ (see §3.1 Table 2 above).

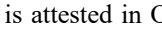
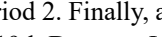
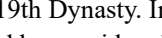
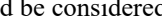
A spelling  is attested in O. IFAO 344.3. The ostracon is unpublished, but it is mentioned in Černý 1943, 174 and Walsem 1982, 222. It comes from Deir el-Medina, and it likely date to Period 2. Finally, a spelling  is attested in O.DeM 1265 col i.18, dating to the late 19th Dynasty. In this case either the group  is a mistake for , or perhaps the form should be considered as spelled in w-orthography.

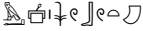
| | | | | | |
|-------|------------|---|--------------------------------|-------------|------------------------|
| II.18 | metal tool |  | mA.sA.sU.Ub.ə ↓ mAsAsUbə | *mvsvs'o:bv | (ε)MCΩBE məš't'o:bə |
| | | mssbt _i | | | |

Eg.: Unpublished Hieratic Ostrakon Gardiner 146, at the Ashmolean Museum, Oxford.

Cpt.: CrCD 186b; ČeCED 91; VyDELC 122; WeKH 102

Notes: The Coptic word refers to a “large needle”. See Černý 1976, 122 for the Egyptian form.

| | | | | | |
|-------|------|---|-------------------------------|------------|----------------------|
| II.19 | comb |  | mA.š0.dU.Ud.ə ↓ mAšdUdə | *mvšd'o:dv | MCYTΩTE məšt'o:tə |
| | | mšddt _i | | | |

Eg.: O.Vienna Aeg. I 9 = LeLE i.210 = HoSW 164.212

Cpt.: CrCD 207b; ČeCED 97; VyDELC 129; WeKH 109

Sem.: **mušda:t(v)* (pl.) – cf. Akk. *mušdu* (sg.), *mušdātu* (pl.) “comb”; the Egyptian may come from a morphologically plural form akin to the Akkadian. The Egyptian vocalisation suggests that the borrowing occurred before the shift /a:/ > /o:/ in Egyptian, namely before Period 2, or that the word was borrowed in Period 2 from an unattested North-West-Semitic form which already underwent the change /a:/ > /o:/ characteristic of the Canaanite vocalic shift.

Notes: see JEA 65 p.96.

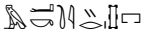
| | | | | | |
|-------|------------|--|-----------------------------|----------|-----------------------|
| II.20 | stronghold |  | mA.k0.tA.ʔr0 ↓ mAktAr | *mvkt'ar | MCCTOΛ (B) mäkt'ol |
| | | mktr | | | |

Eg.: LEM 6 20.2 = LeLE i.212 = HoSW 169.224

Cpt.: CrCD 214b; ČeCED 102; VyDELC 132; WeKH 114

Sem.: see attestations in Period 1 above.

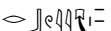
| | | | | | |
|-------|-------------------|---|-------------------------|-------------|--------------------|
| II.21 | lioness, she-bear |  | rA.bU.yA ↓ rAbUyA | *rvb'o:y(v) | *ΛABOI *lāb'o:j |
| | | rb(y) | | | |

Eg.: HPBM3 CB 2 r.2.6-7 (LES 3) = LeLE i.270 = HoSW 202.273

Cpt.: CrCD 136b; ČeCED 69; VyDELC 94; WeKH 75

Sem.: a single common form is hard to reconstruct, but the word is well attested: Arb. *labwa*; Akk. *labbatu*; Heb. *lābīʔ*, *ləbīyāʔ*, all meaning “lioness”.

Notes: the Egyptian form is plural. Only the singular ΛABOI (SB) is attested in Coptic, but a plural *ΛABOIE / *lāb'o:jə can be reconstructed from it on the model of sg. ΩΛOΛ – pl. ΩΛOΛ or sg. ZTO – pl. ZTOP. Such a plural would have been pronounced *rvb'o:y(v), with

a *back* vowel, as suggested also by the group writing spelling, as the shift /a:/ > /o:/ had already taken place by this time.

| | | | | | |
|-------|---------|---|-------|---------|-------------|
| II.22 | husband |  hy | hA.y0 | *h'i/uy | ϩⲁⲓ h'aj |
| | | | ↓ | | |

Eg.: LES 2 3.10,4.7,4.7-8,4.10,12.4,16.2 = LeLE i.284; O.DeM 1639 r7; O.DeM 1223 r4; P.DeM 1 r x 13.6; LES 4 6.9; O.Berlin 10629 v8; O.Berlin 12630 2; P.Leiden I 344 r4.9; P.Leiden I 371 v4; HPBM3 CB 4 r8.1.

Cpt.: CrCD 636b; ĆeCED 269; VyDELIC 290; WeKH 357

Notes: Although the classifiers may vary (ϩ, ϩ̄, ϩ̅), the phonetic part of the word is consistently written ϩⲏⲛⲓⲛⲓ.

| | | | | | |
|-------|--------|---|-------|---------|--------------|
| II.23 | law(s) |  hp | h0.Up | *h'i/up | ϩⲁⲓⲛ h'ap |
| | | | ↓ | | |

Eg.: EHT 1 (P.An. I) 9.2 = LeLE i.287; C.DAI II.2

Cpt.: CrCD 693b–5a; ĆeCED 289; VyDELIC 306; WeKH 381

| | | | | | |
|-------|------|---|-------|------------|----------------|
| II.24 | fare |  hm | h0.Um | *h'i:/u:mv | ϩⲏⲙⲉ h'e:mə |
| | | | ↓ | | |

Eg.: LEM 1 11.8 = LeLE i.288

Cpt.: CrCD 675b; ĆeCED 282; VyDELIC 300; WeKH 371

Notes: probably also in HPBM3 CB 4 v1.4, although now lost in a lacuna. The text is a parallel of LEM 1 11.8.

| | | | | | |
|-------|---------|--|--------------|----------------|-----------|
| II.25 | vinegar |  hmd | hU.m(A).d(A) | *h'i:/u:mvd(v) | ϩⲏⲙⲓⲛ |
| | | | ↓ | *h'i/umdv | ϩⲏⲙⲓⲛ |
| | | | hUm(A)d(A) | < Sem. *humšv | h'e(:)mdʒ |

Eg.: O.ROM 906 20.2 = LeLE i.315 = HoSW 228.316

Cpt.: CrCD 682b; CrCD 285; VyDELIC 303; WeKH 375

Sem.: *humš(v) – cf. Arm. *hūmšā*; Heb. *hōmeš*, both “vinegar”

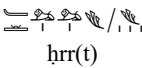
| | | | | | |
|-------|--------|---|----------|--------------|------------------|
| II.26 | flower |  hrr(t) | hU.rU.Ur | *hvr'i:/u:rv | ϩⲏⲣⲏⲉ hr'e:rə |
| | | | ↓ | | |

Eg.: LES 2 8.4,8.9,10.3,12.6,17.4 = LeLE i.328; P.Harris I 5.2, 8.4, 8.12, 21a.2, 21a.6, 21a.7, 21a.8, 21a.9, 21a.10, 21b.1, 29.6, 36b.11, 40b.3, 47.11, 49.8, 56a.8, 73.5 = LeLE i.328; LEM 5 14.6 = LeLE i.328; KRI VI 735.4 (𓆎𓆏𓆑𓆒) = LeLE i.328; HPBM3 CB 5 r2.10

Cpt.: CrCD 704a; ĀCED 294; VyDELIC 310; WeKH 388

Notes: various attestations, both with and without plural strokes. The forms with plural strokes may be collectives. The digitalised slips of the Berlin *Wörterbuch der ägyptischen Sprache* record also the following forms, which date to the II period but which I was unable to track down: 𓆎𓆏𓆑𓆒 (DZA 27.264.170 - Medinet Habu, Room7), 𓆎𓆏𓆑𓆒 (DZA 27.265.040 - block from the temple of Khonsu at Karnak). Another one, 𓆎𓆏𓆑𓆒 (DZA 27.265.270 - Louvre without no.), is just date to the New Kingdom.

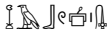
| | | | | | |
|-------|------|---|---------------------------|--------------|------------------------|
| II.27 | lamp |  | h0.Ub.sA ↓ hUb(A)sA | *h'i:/u:bvsv | 2/2HBC (S/B) h'e:bs |
| | | hbs | | | |

Eg.: LEM 2 5,6 = LeLE i.355; LEM 10 7.7 = LeLE i.355; P.Salt 124 1r.20 = LeLE i.355; RAD 22 1r.1 = LeLE i.355; H.O. 35 3r.2 = LeLE i.355

Cpt.: CrCD 658a; ĀCED 275; VyDELIC 290; WeKH 354

| | | | | | |
|-------|-------------|---|-----------------------------------|--|-------------|
| II.28 | tooth, fang |  | hA.n,r0 ↓ hA ⁿ r | *h'a ⁿ r *h ₂ 'ar | ʕoʕ š'ol |
| | | h ⁿ r h ₂ r | | | |

Eg.: KRI V 70.12 (𓆎𓆏𓆑𓆒) = LeLE i.365 = HoSW 243.336; KRI V 63.3 (𓆎𓆏𓆑𓆒) = LeLE i.365 = HoSW 243.336; KRI V 98.2 (𓆎𓆏𓆑𓆒) = LeLE i.365 = HoSW 243.336.

Cpt.: CrCD 557b; ĀCED 239; VyDELIC 260; WeKH 309

Sem.: a Semitic origin for this word is not obvious. The comparison with Semitic *šⁿ, although semantically perfect, is problematic because of unusual correspondence (for this period) of Sem. š and Eg. h. Hoch suggests a possible link with the Sem. √hll “to pierce”, “to bore”.

| | | | | | |
|-------|--------------------------|---|-------------------|-------------------------------|-------------|
| II.29 | road, street, quarter |  | h0.Ur ↓ hUr | *h'i:/u:rv < Sem. *hur(r)v | 2p h'i:r |
| | | hr | | | |

Eg.: LEM 5 11.9 = LeLE i.349; LEM 6 17.5 = LeLE i.349 = HoSW 247.343; LEM 8 9.10 = HoSW 247.343; LEM 5 11.9 = HoSW 247.343

Cpt.: CrCD 696b; ĀCED 291; VyDELIC 307; WeKH 384

Sem.: see attestations in Period 1 above.

of the ρ . This considered, I thus tentatively suggest to read the group ρ as $k-w = kU/Uk$. Caution, however, is needed, and some additional confirmation of this interpretation would be welcome.

| | | | | |
|-------------------------|---------------------------------------|---------------|---------|---------------------|
| | $\text{𓏏} \text{𓏏} \text{𓏏} \text{𓏏}$ | šA.bA.dA/d0.ə | | |
| II.34a staff, rod (sg.) | $\text{𓏏} \text{𓏏} \text{𓏏} \text{𓏏}$ | ↓ | *švb'ad | ϣϣⲔⲟⲧ (S) šəb'ot |
| | šbd | šAbAdA/də | | |

Eg.: P.Mallet 1.7 ($\text{𓏏} \text{𓏏} \text{𓏏} \text{𓏏}$) = HoSW 276.397; HPBM3 CB 5 r7.2 ($\text{𓏏} \text{𓏏} \text{𓏏} \text{𓏏}$) = HoSW 276.397; LEM 6 16.6 ($\text{𓏏} \text{𓏏} \text{𓏏} \text{𓏏}$) = LeLE ii.117-8 = HoSW 276.397; LEM 8 6.6 ($\text{𓏏} \text{𓏏} \text{𓏏} \text{𓏏}$) = LeLE ii.117-8 = HoSW 276.397; RAD 18c 5v.7 ($\text{𓏏} \text{𓏏} \text{𓏏} \text{𓏏}$) = LeLE ii.117-8 = HoSW 276.397

Cpt.: CrCD 554a; ĆeCED 238; VyDELc 258; WeKH 305

Sem.: see attestations in Period 1 above.

Notes: these forms, both Egyptian and Coptic, are singular. Two variants are attested for both the singular and the plural in Coptic, suggesting the existence of two parallel forms of the same word. See II.34a,b,c,d for the distribution and possible attestations of these forms in Period 2.

| | | | | |
|---------------------------|---------------------------------------|--------------|-----------|----------------------|
| | $\text{𓏏} \text{𓏏} \text{𓏏} \text{𓏏}$ | šA.bU.d(A) | | |
| II.34b staffs, rods (pl.) | $\text{𓏏} \text{𓏏} \text{𓏏} \text{𓏏}$ | šA.b0.Ud(.ə) | *švb'o:dv | ϣϣⲔⲟⲧ (S) šəb'o:t |
| | šbd | ↓ | | |
| | | šAbUd(ə) | | |

Eg.: LEM 8 6.6 ($\text{𓏏} \text{𓏏} \text{𓏏} \text{𓏏}$) = LeLE ii.117-8 = HoSW 276.397; LEM 13 1v.9 ($\text{𓏏} \text{𓏏} \text{𓏏} \text{𓏏}$) = LeLE ii.117-8 = HoSW 276.397

Cpt.: CrCD 554a; ĆeCED 238; VyDELc 258; WeKH 305

Sem.: see attestations in Period 1 above.

Notes: these forms, both Egyptian and Coptic, are plural. Two variants are attested for both the singular and the plural in Coptic, suggesting the existence of two parallel forms of the same word. See II.34a,b,c,d for the distribution and possible attestations of these forms in Period 2.

| | | | | |
|-------------------------|---------------------------------------|--------------|-----------|--------------------------|
| | $\text{𓏏} \text{𓏏} \text{𓏏} \text{𓏏}$ | šA.bU.Ud | | |
| II.34c staff, rod (sg.) | $\text{𓏏} \text{𓏏} \text{𓏏} \text{𓏏}$ | šA.bU.t0(.ə) | *švb'o:dv | ϣϣⲔⲟⲧ (B, S?) šəb'o:t |
| | šbd | ↓ | | |
| | | šAbUd(ə) | | |

Eg.: O.Gard. 296.2 ($\text{𓏏} \text{𓏏} \text{𓏏} \text{𓏏}$) = HoSW 276.397; O.Gard. 135.2-3 ($\text{𓏏} \text{𓏏} \text{𓏏} \text{𓏏}$) = HoSW 276.397; O.Turin 57387 10 ($\text{𓏏} \text{𓏏} \text{𓏏} \text{𓏏}$) = HoSW 276.397; O.Berlin 12398 ($\text{𓏏} \text{𓏏} \text{𓏏} \text{𓏏}$) = LeLE ii.115 = HoSW 276.397

Cpt.: CrCD 554a; ĆeCED 238; VyDELIC 258; WeKH 305

Sem.: see attestations in Period 1 above.

Notes: these forms, both Egyptian and Coptic, are singular. Two variants are attested for both the singular and the plural in Coptic, suggesting the existence of two parallel forms of the same word. See II.34a,b,c,d for the distribution and possible attestations of these forms in Period 2.

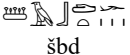
| | | | | |
|--------|--------------------|--|---|---------------------|
| | | šA.bA.d0.ə | | |
| II.34d | staffs, rods (pl.) |  šbd | ↓ | *švb'adyv |
| | | šAbAdə | | ϣⲃⲟⲓ (B) šəb'otə |

Eg.: LEM 10 7.2 = LeLE ii.117-8 = HoSW 276.397

Cpt.: CrCD 554a; ĆeCED 238; VyDELIC 258; WeKH 305

Sem.: see attestations in Period 1 above.

Notes: these forms, both Egyptian and Coptic, are plural. Two variants are attested for both the singular and the plural in Coptic, suggesting the existence of two parallel forms of the same word. See II.34a,b,c,d for the distribution and possible attestations of these forms in Period 2.

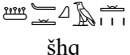
| | | | | |
|-------|------|--|---|--------------------|
| | | šA.hU.qA | | |
| II.35 | dust |  šhq | ↓ | *švh'i:/u:qv |
| | | šAhUqA | | ϣ(2)ⲓⲥ šəh'i:ki |

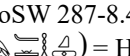
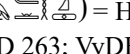
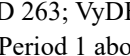
Eg.: EHT 1 (P.An. I) 10.2 () = LeLE ii.133 = HoSW 287-8.411; O.Berlin 11236 () = HoSW 287-8.411; O.Cairo 25553 7 () = HoSW 287-8.411; C.DAI II.10 () = HoSW 287-8.411

Cpt.: CrCD 612b; ĆeCED 263; VyDELIC 277; WeKH 341

Sem.: see attestations in Period 1 above.

| | | | | |
|-------|--------|---|---|-----------------|
| | | šA.kA.rA.šA | | |
| II.36 | basket |  škrš | ↓ | *švk'i:/u:rvšv |
| | | šAkArAšA | | ϣⲕⲓⲗ šək'i:l |

Eg.: TR 10068 (Pl.12) 5r.17 = LeLE ii.137, H.O 20 2.5-6 = LeLE ii.137

Cpt.: CrCD 556b; ĆeCED 238-9; WeKH 308

Notes: the Coptic form means “curl/plait of hair”.

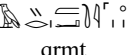
| | | | | |
|-------|---------------------------|---|---|--------------------------|
| | | qA.r0.mA.tA | | |
| II.37 | ashes, cinders, embers |  qrmt | ↓ | *k'i/urmv(t) < Sem. — |
| | | qArmAtA | | κ(ε)ⲣⲏⲉ k'ermə |

Eg.: KRI IV 9.11 = LeLE ii.156 = HoSW 301.435.

Cpt.: CrCD 117a; ČeCED 62; VyDELIC 85–6; WeKH 68

Sem.: see discussion §6

Notes: The Egyptian is likely collective. Vycichl 1984, 85–6 think that there the Coptic form may have been influenced by a confusion with the words for “fire”, “smoke” and “darkness”.

| | | | | | |
|-------|----------------|---|-------------------------|--------------|-----------------|
| II.38 | burnt-offering |  | qA.rA.rA ↓ qArArA | *qvr'i:/u:rv | Ⲅⲗⲗ k'el'i:l |
|-------|----------------|---|-------------------------|--------------|-----------------|

Eg.: DZA 30.402.230; DZA 30.402.240; P.Turin 1882r/PdT 73ii.3 ()

Cpt.: CrCD 811a; ČeCED 328; VyDELIC 338; WeKH 452

Notes: I was unable to track down the precise location of the first two attestations mentioned in the digitalised slips of the Berlin *Wörterbuch der ägyptischen Sprache* (DZA 30.402.230; DZA 30.402.240). According to the slips, however, they come from walls in Karnak and date to the reign of Ramses III.

| | | | | | |
|-------|----------------|---|------------------------|-----------|----------------|
| II.39 | precious stone |  | qA.r0.tA ↓ qArtA | *q'i/ultv | Ⲅⲗⲧⲉ k'eltə |
|-------|----------------|---|------------------------|-----------|----------------|

Eg.: P.Harris I 64a.9; HPBM3 CB 4 v8.6

Cpt.: CrCD 813a; ČeCED 329; VyDELIC 339; WeKH 453

Notes: Coptic Morphologically plural or collective, like the Egyptian form? The Coptic means “ring (with a seal)”

| | | | | | |
|-------|----------------|---|-------------------|---------|---------------|
| II.40 | (palm of) hand |  | k0.Up ↓ kUp | *k'a/op | Ⲅⲟⲡ k'i'op |
|-------|----------------|---|-------------------|---------|---------------|





Eg.:  KRI IV 8.15 = LeLE ii.172 = HoSW 317-8.457

Cpt.: CrCD 824b; ČeCED 334; VyDELIC 344; WeKH 462

Sem.: *kap(pu) – cf. Akk. *kappu*; Arb. *kaff*; Arm. *kappā*; Eth. *kāf*; Heb. *kaf*; Syr. *kappā*, all “palm”, “sole”

Notes: Forms of the type  (+ dets) are widely attested (see HoSW 317-8.457 LeLE ii.172), but I think they may have to be interpreted as instances of *w*-orthography rather than as examples of group writing.

| | | | | | |
|-------|------------|--|-----------------------------|---------|-----------------|
| II.41 | couch, bed |  crk | kA.rA.k(A) ↓ kArAk(A) | *kvr'ak | κλoσ k'l'okj |
|-------|------------|--|-----------------------------|---------|-----------------|

Eg.: O.Gard 158.6 () = LeLE ii.117 = HoSW 333-4.486; O.Vienna H 1.4 () = HoSW 333-4.486; O.Gard 194 II.18 () = HoSW 333-4.486; O.Cairo 25679 12 () = HoSW 333-4.486; O.DeM 434 II.4 () = HoSW 333-4.486

Cpt.: CrCD 815a, var.s: κλoσ, τλ. (S); κλoχ (BF); χλ. (B); κλαδ (AA²F); δαλεχ (F); ĆeCED 330; VyDELC 340; WeKH 454

Sem.: see attestations in Period 1 above.

| | | | | | |
|-------|------------------------------|--|------------------------|---------|--------------------|
| II.42 | hair-cloth, sacking, sack |  gwn | gA.w0.nA ↓ gAwnA | *k'awnv | κooyne k'i'ownə |
|-------|------------------------------|--|------------------------|---------|--------------------|

Eg.: KRI IV 14.8 = LeLE ii.186 = HoSW 347.508

Cpt.: CrCD 836a; ĆeCED 339; VyDELC 349; WeKH 470, 574

Sem.: unclear, possibly related with Arb. *jūna* “basket”?

Notes: Morphologically plural or collective, like the Egyptian form?

| | | | | | |
|-------|-------------|--|------------------------|-----------|------------------|
| II.43 | finger-ring |  gsr | gA.s0.Ur ↓ gAsUr | *gvs'o:rv | κcoyp kəs'u:r |
|-------|-------------|--|------------------------|-----------|------------------|

Eg.: P.Harris I 13a.6, 13b.2, 64a.15, 64b.7, 64b.10 = LeLE ii.195 = HoSW 355.523

Cpt.: CrCD 121b; ĆeCED 64; VyDELC 154; WeKH 70

Sem.: **qiθu:r(v)* – cf. Arm. *qīṭṭūrā* “wreathing”, “plaiting”; Heb. *qiššūrīm* (pl.) “breastbands?”, “beads”, “ornaments”; see also Heb. *√qšr* “bind on ornaments”

Notes: on the basis of the context, the Egyptian word is likely singular (see HoSW 355.523)

| | | | | | |
|-------|---------------|---|---------------------------------------|--------------------------------|-------------|
| II.44 | heap, hillock |  tr | tA.nr(ə) ↓ tA ^{nr} (ə) | *t'i/ur(rv) < Sem. *til(lv) | τλλ t'al |
|-------|---------------|---|---------------------------------------|--------------------------------|-------------|

Eg.: LEM 9 2v.6 = LeLE ii.214 = HoSW 356.527; LEM 3 2.5 () = HoSW 356.527

Cpt.: CrCD 408a; ĆeCED 185; VyDELC 213; WeKH 229

Sem.: **til(lv)* – cf. Akk. *tillu*; Arb. *tall*; Arm. *tillā*; Heb. *tel*; Syr. *tellā*, all “hill”

Notes: Akkadian, Aramic, Hebrew and Syriac point to **til(lu)*; the Arabic with /a/ is thus clearly irregular.

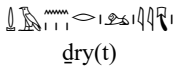
| | | | | | |
|-------|----------|---|--|-------------|--------------|
| II.48 | scorpion |  dry(t) | dA.n ₁ r0.rU.yA ↓ dA ⁿ (r)rUyA | *dvr'i:u:yv | Ⲅⲗⲏ kl'e: |
|-------|----------|---|--|-------------|--------------|

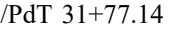
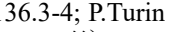
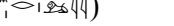
Eg.: P.Turin 1993 r10/PdT 31+77.14 (); P.Turin 1993 v4/PdT 135.10; P.Turin 1993 v5/PdT 136.3-4; P.Turin 1993 v6/PdT 137.4; HPBM3 CB 5 r3.1 (), 3.2 (

Cpt.: CrCD 810a; ĆeCED 327; VyDELc 337; WeKH 449

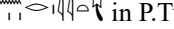
Notes: misspelled  in P.Turin 1993 v8/PdT 120.10.

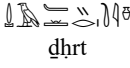
| | | | | | |
|-------|-----------|--|------------------------------|---|----------------------|
| II.49 | jar, bowl |  dhr̄t | dA.hU.yr0.tA ↓ dAhUrtA | *dvh'i/urtv > *dvr'i/uh̄tv < Sem. *švluḫi:t | ⲭⲗⲁⲓⲛⲥ dʒəl'ahtəs |
|-------|-----------|--|------------------------------|---|----------------------|

Eg.: O.DeM 318v 8 = HoSW 394.593

Cpt.: CrCD 770a; ĆeCED 314; VyDELc 326; WeKH 421

Sem.: *švluḫi:t / *švllōḫt(v) – cf. Amarna Cananite *šillaḫta* “a jar”; Arm. *šəluḫūtā* “flask”; Heb.1 *šallahat* “dish”; Heb.2 *šəlohūt* “jar”; Syr. *šəluḫūtā* “flask”

Notes: Coptic: “deep pit”, “vessel”. The -c of ⲭⲗⲁⲓⲛⲥ is either the common Coptic suffix, or should be emended into -e as suggested by Crum (770a).

Period 3

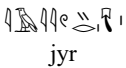
| | | | | | |
|-------|-----------|---|-------------------------|-----------|----------------|
| III.1 | stag, ram |  jyr | jA.yU.rA ↓ jAyUrA | *?vy'o:rv | ⲉⲓⲟⲗⲗ j'u:l |
|-------|-----------|---|-------------------------|-----------|----------------|

Eg.: LES 5 3.68 = LeLE i.12 = HoSW 17.1

Cpt.: CrCD 77a; ĆeCED 46; VyDELc 62; WeKH 49

Sem.: *šayyal(u) – cf. Akk. *ayyalu*; Amorite *šayyalum*; Arb. *šayyil*, *šai/uyyal*; Arm. *šayyālā*; Eth. *hayyal*; Heb. *šayyāl* “stag”, Syr. *šayyālā*, all “stag”

Notes: the Coptic word means “hart”, “hind”. The Egyptian form implies the presence of a *back* vowel, which suggests either than the word was borrowed into Egyptian before the Egyptian shift /a:/ > /o:/, therefore before Period 2, or that it was borrowed from a Semitic language in which this word underwent the shift /a:/ > /o:/ within the frame of the Canaanite vocalic shift. In the latter case, Phoenician would likely be the best candidate, as already noticed by Hoch 1994, 17.

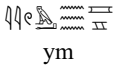
| | | | | | |
|-------|-----|---|-------------------|-------|--------------|
| III.2 | sea |  ym | yU.m0 ↓ yUm | *y'om | ⲉⲓⲟⲙ j'om |
|-------|-----|---|-------------------|-------|--------------|

Eg.: LES 5,1,8 1,23 1x+13 1x+14 =LeLE i.28 = HoSW 52-3.52; Gloss. Gol 1.8 (AEO I no. 25) = HoSW 52-3.52; P.Hood I 7-8 (AEO II no. 25) = HoSW 52-3.52; LLR r9 (AEO I no. 25) = HoSW 52-3.52

Cpt.: CrCD 77a; ČeCED 46; VyDELIC 63; WeKH 49

Sem.: see attestations in Period 1 above.

Notes: see attestations in Period 1 above.

| | | |
|-------|---------------------------|---|
| III.3 | stones, rocks, pebbles | 𓆎𓆏𓆐𓆑𓆒𓆓𓆔𓆕𓆖𓆗𓆘𓆙𓆚𓆛𓆜𓆝𓆞𓆟𓆠𓆡𓆢𓆣𓆤𓆥𓆦𓆧𓆨𓆩𓆪𓆫𓆬𓆭𓆮𓆯𓆰𓆱𓆲𓆳𓆴𓆵𓆶𓆷𓆸𓆹𓆺𓆻𓆼𓆽𓆾𓆿𓇀𓇁𓇂𓇃𓇄𓇅𓇆𓇇𓇈𓇉𓇊𓇋𓇌𓇍𓇎𓇏𓇐𓇑𓇒𓇓𓇔𓇕𓇖𓇗𓇘𓇙𓇚𓇛𓇜𓇝𓇞𓇟𓇠𓇡𓇢𓇣𓇤𓇥𓇦𓇧𓇨𓇩𓇪𓇫𓇬𓇭𓇮𓇯𓇰𓇱𓇲𓇳𓇴𓇵𓇶𓇷𓇸𓇹𓇺𓇻𓇼𓇽𓇾𓇿𓈀𓈁𓈂𓈃𓈄𓈅𓈆𓈇𓈈𓈉𓈊𓈋𓈌𓈍𓈎𓈏𓈐𓈑𓈒𓈓𓈔𓈕𓈖𓈗𓈘𓈙𓈚𓈛𓈜𓈝𓈞𓈟𓈠𓈡𓈢𓈣𓈤𓈥𓈦𓈧𓈨𓈩𓈪𓈫𓈬𓈭𓈮𓈯𓈰𓈱𓈲𓈳𓈴𓈵𓈶𓈷𓈸𓈹𓈺𓈻𓈼𓈽𓈾𓈿𓉀𓉁𓉂𓉃𓉄𓉅𓉆𓉇𓉈𓉉𓉊𓉋𓉌𓉍𓉎𓉏𓉐𓉑𓉒𓉓𓉔𓉕𓉖𓉗𓉘𓉙𓉚𓉛𓉜𓉝𓉞𓉟𓉠𓉡𓉢𓉣𓉤𓉥𓉦𓉧𓉨𓉩𓉪𓉫𓉬𓉭𓉮𓉯𓉰𓉱𓉲𓉳𓉴𓉵𓉶𓉷𓉸𓉹𓉺𓉻𓉼𓉽𓉾𓉿𓊀𓊁𓊂𓊃𓊄𓊅𓊆𓊇𓊈𓊉𓊊𓊋𓊌𓊍𓊎𓊏𓊐𓊑𓊒𓊓𓊔𓊕𓊖𓊗𓊘𓊙𓊚𓊛𓊜𓊝𓊞𓊟𓊠𓊡𓊢𓊣𓊤𓊥𓊦𓊧𓊨𓊩𓊪𓊫𓊬𓊭𓊮𓊯𓊰𓊱𓊲𓊳𓊴𓊵𓊶𓊷𓊸𓊹𓊺𓊻𓊼𓊽𓊾𓊿𓋀𓋁𓋂𓋃𓋄𓋅𓋆𓋇𓋈𓋉𓋊𓋋𓋌𓋍𓋎𓋏𓋐𓋑𓋒𓋓𓋔𓋕𓋖𓋗𓋘𓋙𓋚𓋛𓋜𓋝𓋞𓋟𓋠𓋡𓋢𓋣𓋤𓋥𓋦𓋧𓋨𓋩𓋪𓋫𓋬𓋭𓋮𓋯𓋰𓋱𓋲𓋳𓋴𓋵𓋶𓋷𓋸𓋹𓋺𓋻𓋼𓋽𓋾𓋿𓌀𓌁𓌂𓌃𓌄𓌅𓌆𓌇𓌈𓌉𓌊𓌋𓌌𓌍𓌎𓌏𓌐𓌑𓌒𓌓𓌔𓌕𓌖𓌗𓌘𓌙𓌚𓌛𓌜𓌝𓌞𓌟𓌠𓌡𓌢𓌣𓌤𓌥𓌦𓌧𓌨𓌩𓌪𓌫𓌬𓌭𓌮𓌯𓌰𓌱𓌲𓌳𓌴𓌵𓌶𓌷𓌸𓌹𓌺𓌻𓌼𓌽𓌾𓌿𓍀𓍁𓍂𓍃𓍄𓍅𓍆𓍇𓍈𓍉𓍊𓍋𓍌𓍍𓍎𓍏𓍐𓍑𓍒𓍓𓍔𓍕𓍖𓍗𓍘𓍙𓍚𓍛𓍜𓍝𓍞𓍟𓍠𓍡𓍢𓍣𓍤𓍥𓍦𓍧𓍨𓍩𓍪𓍫𓍬𓍭𓍮𓍯𓍰𓍱𓍲𓍳𓍴𓍵𓍶𓍷𓍸𓍹𓍺𓍻𓍼𓍽𓍾𓍿𓎀𓎁𓎂𓎃𓎄𓎅𓎆𓎇𓎈𓎉𓎊𓎋𓎌𓎍𓎎𓎏𓎐𓎑𓎒𓎓𓎔𓎕𓎖𓎗𓎘𓎙𓎚𓎛𓎜𓎝𓎞𓎟𓎠𓎡𓎢𓎣𓎤𓎥𓎦𓎧𓎨𓎩𓎪𓎫𓎬𓎭𓎮𓎯𓎰𓎱𓎲𓎳𓎴𓎵𓎶𓎷𓎸𓎹𓎺𓎻𓎼𓎽𓎾𓎿𓏀𓏁𓏂𓏃𓏄𓏅𓏆𓏇𓏈𓏉𓏊𓏋𓏌𓏍𓏎𓏏𓏐𓏑𓏒𓏓𓏔𓏕𓏖𓏗𓏘𓏙𓏚𓏛𓏜𓏝𓏞𓏟𓏠𓏡𓏢𓏣𓏤𓏥𓏦𓏧𓏨𓏩𓏪𓏫𓏬𓏭𓏮𓏯𓏰𓏱𓏲𓏳𓏴𓏵𓏶𓏷𓏸𓏹𓏺𓏻𓏼𓏽𓏾𓏿𓐀𓐁𓐂𓐃𓐄𓐅𓐆𓐇𓐈𓐉𓐊𓐋𓐌𓐍𓐎𓐏𓐐𓐑𓐒𓐓𓐔𓐕𓐖𓐗𓐘𓐙𓐚𓐛𓐜𓐝𓐞𓐟𓐠𓐡𓐢𓐣𓐤𓐥𓐦𓐧𓐨𓐩𓐪𓐫𓐬𓐭𓐮𓐯𓐰𓐱𓐲𓐳𓐴𓐵𓐶𓐷𓐸𓐹𓐺𓐻𓐼𓐽𓐾𓐿𓑀𓑁𓑂𓑃𓑄𓑅𓑆𓑇𓑈𓑉𓑊𓑋𓑌𓑍𓑎𓑏𓑐𓑑𓑒𓑓𓑔𓑕𓑖𓑗𓑘𓑙𓑚𓑛𓑜𓑝𓑞𓑟𓑠𓑡𓑢𓑣𓑤𓑥𓑦𓑧𓑨𓑩𓑪𓑫𓑬𓑭𓑮𓑯𓑰𓑱𓑲𓑳𓑴𓑵𓑶𓑷𓑸𓑹𓑺𓑻𓑼𓑽𓑾𓑿𓒀𓒁𓒂𓒃𓒄𓒅𓒆𓒇𓒈𓒉𓒊𓒋𓒌𓒍𓒎𓒏𓒐𓒑𓒒𓒓𓒔𓒕𓒖𓒗𓒘𓒙𓒚𓒛𓒜𓒝𓒞𓒟𓒠𓒡𓒢𓒣𓒤𓒥𓒦𓒧𓒨𓒩𓒪𓒫𓒬𓒭𓒮𓒯𓒰𓒱𓒲𓒳𓒴𓒵𓒶𓒷𓒸𓒹𓒺𓒻𓒼𓒽𓒾𓒿𓓀𓓁𓓂𓓃𓓄𓓅𓓆𓓇𓓈𓓉𓓊𓓋𓓌𓓍𓓎𓓏𓓐𓓑𓓒𓓓𓓔𓓕𓓖𓓗𓓘𓓙𓓚𓓛𓓜𓓝𓓞𓓟𓓠𓓡𓓢𓓣𓓤𓓥𓓦𓓧𓓨𓓩𓓪𓓫𓓬𓓭𓓮𓓯𓓰𓓱𓓲𓓳𓓴𓓵𓓶𓓷𓓸𓓹𓓺𓓻𓓼𓓽𓓾𓓿𓔀𓔁𓔂𓔃𓔄𓔅𓔆𓔇𓔈𓔉𓔊𓔋𓔌𓔍𓔎𓔏𓔐𓔑𓔒𓔓𓔔𓔕𓔖𓔗𓔘𓔙𓔚𓔛𓔜𓔝𓔞𓔟𓔠𓔡𓔢𓔣𓔤𓔥𓔦𓔧𓔨𓔩𓔪𓔫𓔬𓔭𓔮𓔯𓔰𓔱𓔲𓔳𓔴𓔵𓔶𓔷𓔸𓔹𓔺𓔻𓔼𓔽𓔾𓔿𓕀𓕁𓕂𓕃𓕄𓕅𓕆𓕇𓕈𓕉𓕊𓕋𓕌𓕍𓕎𓕏𓕐𓕑𓕒𓕓𓕔𓕕𓕖𓕗𓕘𓕙𓕚𓕛𓕜𓕝𓕞𓕟𓕠𓕡𓕢𓕣𓕤𓕥𓕦𓕧𓕨𓕩𓕪𓕫𓕬𓕭𓕮𓕯𓕰𓕱𓕲𓕳𓕴𓕵𓕶𓕷𓕸𓕹𓕺𓕻𓕼𓕽𓕾𓕿𓖀𓖁𓖂𓖃𓖄𓖅𓖆𓖇𓖈𓖉𓖊𓖋𓖌𓖍𓖎𓖏𓖐𓖑𓖒𓖓𓖔𓖕𓖖𓖗𓖘𓖙𓖚𓖛𓖜𓖝𓖞𓖟𓖠𓖡𓖢𓖣𓖤𓖥𓖦𓖧𓖨𓖩𓖪𓖫𓖬𓖭𓖮𓖯𓖰𓖱𓖲𓖳𓖴𓖵𓖶𓖷𓖸𓖹𓖺𓖻𓖼𓖽𓖾𓖿𓗀𓗁𓗂𓗃𓗄𓗅𓗆𓗇𓗈𓗉𓗊𓗋𓗌𓗍𓗎𓗏𓗐𓗑𓗒𓗓𓗔𓗕𓗖𓗗𓗘𓗙𓗚𓗛𓗜𓗝𓗞𓗟𓗠𓗡𓗢𓗣𓗤𓗥𓗦𓗧𓗨𓗩𓗪𓗫𓗬𓗭𓗮𓗯𓗰𓗱𓗲𓗳𓗴𓗵𓗶𓗷𓗸𓗹𓗺𓗻𓗼𓗽𓗾𓗿𓘀𓘁𓘂𓘃𓘄𓘅𓘆𓘇𓘈𓘉𓘊𓘋𓘌𓘍𓘎𓘏𓘐𓘑𓘒𓘓𓘔𓘕𓘖𓘗𓘘𓘙𓘚𓘛𓘜𓘝𓘞𓘟𓘠𓘡𓘢𓘣𓘤𓘥𓘦𓘧𓘨𓘩𓘪𓘫𓘬𓘭𓘮𓘯𓘰𓘱𓘲𓘳𓘴𓘵𓘶𓘷𓘸𓘹𓘺𓘻𓘼𓘽𓘾𓘿𓙀𓙁𓙂𓙃𓙄𓙅𓙆𓙇𓙈𓙉𓙊𓙋𓙌𓙍𓙎𓙏𓙐𓙑𓙒𓙓𓙔𓙕𓙖𓙗𓙘𓙙𓙚𓙛𓙜𓙝𓙞𓙟𓙠𓙡𓙢𓙣𓙤𓙥𓙦𓙧𓙨𓙩𓙪𓙫𓙬𓙭𓙮𓙯𓙰𓙱𓙲𓙳𓙴𓙵𓙶𓙷𓙸𓙹𓙺𓙻𓙼𓙽𓙾𓙿𓚀𓚁𓚂𓚃𓚄𓚅𓚆𓚇𓚈𓚉𓚊𓚋𓚌𓚍𓚎𓚏𓚐𓚑𓚒𓚓𓚔𓚕𓚖𓚗𓚘𓚙𓚚𓚛𓚜𓚝𓚞𓚟𓚠𓚡𓚢𓚣𓚤𓚥𓚦𓚧𓚨𓚩𓚪𓚫𓚬𓚭𓚮𓚯𓚰𓚱𓚲𓚳𓚴𓚵𓚶𓚷𓚸𓚹𓚺𓚻𓚼𓚽𓚾𓚿𓛀𓛁𓛂𓛃𓛄𓛅𓛆𓛇𓛈𓛉𓛊𓛋𓛌𓛍𓛎𓛏𓛐𓛑𓛒𓛓𓛔𓛕𓛖𓛗𓛘𓛙𓛚𓛛𓛜𓛝𓛞𓛟𓛠𓛡𓛢𓛣𓛤𓛥𓛦𓛧𓛨𓛩𓛪𓛫𓛬𓛭𓛮𓛯𓛰𓛱𓛲𓛳𓛴𓛵𓛶𓛷𓛸𓛹𓛺𓛻𓛼𓛽𓛾𓛿𓜀𓜁𓜂𓜃𓜄𓜅𓜆𓜇𓜈𓜉𓜊𓜋𓜌𓜍𓜎𓜏𓜐𓜑𓜒𓜓𓜔𓜕𓜖𓜗𓜘𓜙𓜚𓜛𓜜𓜝𓜞𓜟𓜠𓜡𓜢𓜣𓜤𓜥𓜦𓜧𓜨𓜩𓜪𓜫𓜬𓜭𓜮𓜯𓜰𓜱𓜲𓜳𓜴𓜵𓜶𓜷𓜸𓜹𓜺𓜻𓜼𓜽𓜾𓜿𓝀𓝁𓝂𓝃𓝄𓝅𓝆𓝇𓝈𓝉𓝊𓝋𓝌𓝍𓝎𓝏𓝐𓝑𓝒𓝓𓝔𓝕𓝖𓝗𓝘𓝙𓝚𓝛𓝜𓝝𓝞𓝟𓝠𓝡𓝢𓝣𓝤𓝥𓝦𓝧𓝨𓝩𓝪𓝫𓝬𓝭𓝮𓝯𓝰𓝱𓝲𓝳𓝴𓝵𓝶𓝷𓝸𓝹𓝺𓝻𓝼𓝽𓝾𓝿𓞀𓞁𓞂𓞃𓞄𓞅𓞆𓞇𓞈𓞉𓞊𓞋𓞌𓞍𓞎𓞏𓞐𓞑𓞒𓞓𓞔𓞕𓞖𓞗𓞘𓞙𓞚𓞛𓞜𓞝𓞞𓞟𓞠𓞡𓞢𓞣𓞤𓞥𓞦𓞧𓞨𓞩𓞪𓞫𓞬𓞭𓞮𓞯𓞰𓞱𓞲𓞳𓞴𓞵𓞶𓞷𓞸𓞹𓞺𓞻𓞼𓞽𓞾𓞿𓟀𓟁𓟂𓟃𓟄𓟅𓟆𓟇𓟈𓟉𓟊𓟋𓟌𓟍𓟎𓟏𓟐𓟑𓟒𓟓𓟔𓟕𓟖𓟗𓟘𓟙𓟚𓟛𓟜𓟝𓟞𓟟𓟠𓟡𓟢𓟣𓟤𓟥𓟦𓟧𓟨𓟩𓟪𓟫𓟬𓟭𓟮𓟯𓟰𓟱𓟲𓟳𓟴𓟵𓟶𓟷𓟸𓟹𓟺𓟻𓟼𓟽𓟾𓟿𓠀𓠁𓠂𓠃𓠄𓠅𓠆𓠇𓠈𓠉𓠊𓠋𓠌𓠍𓠎𓠏𓠐𓠑𓠒𓠓𓠔𓠕𓠖𓠗𓠘𓠙𓠚𓠛𓠜𓠝𓠞𓠟𓠠𓠡𓠢𓠣𓠤𓠥𓠦𓠧𓠨𓠩𓠪𓠫𓠬𓠭𓠮𓠯𓠰𓠱𓠲𓠳𓠴𓠵𓠶𓠷𓠸𓠹𓠺𓠻𓠼𓠽𓠾𓠿𓡀𓡁𓡂𓡃𓡄𓡅𓡆𓡇𓡈𓡉𓡊𓡋𓡌𓡍𓡎𓡏𓡐𓡑𓡒𓡓𓡔𓡕𓡖𓡗𓡘𓡙𓡚𓡛𓡜𓡝𓡞𓡟𓡠𓡡𓡢𓡣𓡤𓡥𓡦𓡧𓡨𓡩𓡪𓡫𓡬𓡭𓡮𓡯𓡰𓡱𓡲𓡳𓡴𓡵𓡶𓡷𓡸𓡹𓡺𓡻𓡼𓡽𓡾𓡿𓢀𓢁𓢂𓢃𓢄𓢅𓢆𓢇𓢈𓢉𓢊𓢋𓢌𓢍𓢎𓢏𓢐𓢑𓢒𓢓𓢔𓢕𓢖𓢗𓢘𓢙𓢚𓢛𓢜𓢝𓢞𓢟𓢠𓢡𓢢𓢣𓢤𓢥𓢦𓢧𓢨𓢩𓢪𓢫𓢬𓢭𓢮𓢯𓢰𓢱𓢲𓢳𓢴𓢵𓢶𓢷𓢸𓢹𓢺𓢻𓢼𓢽𓢾𓢿𓣀𓣁𓣂𓣃𓣄𓣅𓣆𓣇𓣈𓣉𓣊𓣋𓣌𓣍𓣎𓣏𓣐𓣑𓣒𓣓𓣔𓣕𓣖𓣗𓣘𓣙𓣚𓣛𓣜𓣝𓣞𓣟𓣠𓣡𓣢𓣣𓣤𓣥𓣦𓣧𓣨𓣩𓣪𓣫𓣬𓣭𓣮𓣯𓣰𓣱𓣲𓣳𓣴𓣵𓣶𓣷𓣸𓣹𓣺𓣻𓣼𓣽𓣾𓣿𓤀𓤁𓤂𓤃𓤄𓤅𓤆𓤇𓤈𓤉𓤊𓤋𓤌𓤍𓤎𓤏𓤐𓤑𓤒𓤓𓤔𓤕𓤖𓤗𓤘𓤙𓤚𓤛𓤜𓤝𓤞𓤟𓤠𓤡𓤢𓤣𓤤𓤥𓤦𓤧𓤨𓤩𓤪𓤫𓤬𓤭𓤮𓤯𓤰𓤱𓤲𓤳𓤴𓤵𓤶𓤷𓤸𓤹𓤺𓤻𓤼𓤽𓤾𓤿𓥀𓥁𓥂𓥃𓥄𓥅𓥆𓥇𓥈𓥉𓥊𓥋𓥌𓥍𓥎𓥏𓥐𓥑𓥒𓥓𓥔𓥕𓥖𓥗𓥘𓥙𓥚𓥛𓥜𓥝𓥞𓥟𓥠𓥡𓥢𓥣𓥤𓥥𓥦𓥧𓥨𓥩𓥪𓥫𓥬𓥭𓥮𓥯𓥰𓥱𓥲𓥳𓥴𓥵𓥶𓥷𓥸𓥹𓥺𓥻𓥼𓥽𓥾𓥿𓦀𓦁𓦂𓦃𓦄𓦅𓦆𓦇𓦈𓦉𓦊𓦋𓦌𓦍𓦎𓦏𓦐𓦑𓦒𓦓𓦔𓦕𓦖𓦗𓦘𓦙𓦚𓦛𓦜𓦝𓦞𓦟𓦠𓦡𓦢𓦣𓦤𓦥𓦦𓦧𓦨𓦩𓦪𓦫𓦬𓦭𓦮𓦯𓦰𓦱𓦲𓦳𓦴𓦵𓦶𓦷𓦸𓦹𓦺𓦻𓦼𓦽𓦾𓦿𓧀𓧁𓧂𓧃𓧄𓧅𓧆𓧇𓧈𓧉𓧊𓧋𓧌𓧍𓧎𓧏𓧐𓧑𓧒𓧓𓧔𓧕𓧖𓧗𓧘𓧙𓧚𓧛𓧜𓧝𓧞𓧟𓧠𓧡𓧢𓧣𓧤𓧥𓧦𓧧𓧨𓧩𓧪𓧫𓧬𓧭𓧮𓧯𓧰𓧱𓧲𓧳𓧴𓧵𓧶𓧷𓧸𓧹𓧺𓧻𓧼𓧽𓧾𓧿𓨀𓨁𓨂𓨃𓨄𓨅𓨆𓨇𓨈𓨉𓨊𓨋𓨌𓨍𓨎𓨏𓨐𓨑𓨒𓨓𓨔𓨕𓨖𓨗𓨘𓨙𓨚𓨛𓨜𓨝𓨞𓨟𓨠𓨡𓨢𓨣𓨤𓨥𓨦𓨧𓨨𓨩𓨪𓨫𓨬𓨭𓨮𓨯𓨰𓨱𓨲𓨳𓨴𓨵𓨶𓨷𓨸𓨹𓨺𓨻𓨼𓨽𓨾𓨿𓩀𓩁𓩂𓩃𓩄𓩅𓩆𓩇𓩈𓩉𓩊𓩋𓩌𓩍𓩎𓩏𓩐𓩑𓩒𓩓𓩔𓩕𓩖𓩗𓩘𓩙𓩚𓩛𓩜𓩝𓩞𓩟𓩠𓩡𓩢𓩣𓩤𓩥𓩦𓩧𓩨𓩩𓩪𓩫𓩬𓩭𓩮𓩯𓩰𓩱𓩲𓩳𓩴𓩵𓩶𓩷𓩸𓩹𓩺𓩻𓩼𓩽𓩾𓩿𓪀𓪁𓪂𓪃𓪄𓪅𓪆𓪇𓪈𓪉𓪊𓪋𓪌𓪍𓪎𓪏𓪐𓪑𓪒𓪓𓪔𓪕𓪖𓪗𓪘𓪙𓪚𓪛𓪜𓪝𓪞𓪟𓪠𓪡𓪢𓪣𓪤𓪥𓪦𓪧𓪨𓪩𓪪𓪫𓪬𓪭𓪮𓪯𓪰𓪱𓪲𓪳𓪴𓪵𓪶𓪷𓪸𓪹𓪺𓪻𓪼𓪽𓪾𓪿𓫀𓫁𓫂𓫃𓫄𓫅𓫆𓫇𓫈𓫉𓫊𓫋𓫌𓫍𓫎𓫏𓫐𓫑𓫒𓫓𓫔𓫕𓫖𓫗𓫘𓫙𓫚𓫛𓫜𓫝𓫞𓫟𓫠𓫡𓫢𓫣𓫤𓫥𓫦𓫧𓫨𓫩𓫪𓫫𓫬𓫭𓫮𓫯𓫰𓫱𓫲𓫳𓫴𓫵𓫶𓫷𓫸𓫹𓫺𓫻𓫼𓫽𓫾𓫿𓬀𓬁𓬂𓬃𓬄𓬅𓬆𓬇𓬈𓬉𓬊𓬋𓬌𓬍𓬎𓬏𓬐𓬑𓬒𓬓𓬔𓬕𓬖𓬗𓬘𓬙𓬚𓬛𓬜𓬝𓬞𓬟𓬠𓬡𓬢𓬣𓬤𓬥𓬦𓬧𓬨𓬩𓬪𓬫𓬬𓬭𓬮𓬯𓬰𓬱𓬲𓬳𓬴𓬵𓬶𓬷𓬸𓬹𓬺𓬻𓬼𓬽𓬾𓬿𓭀𓭁𓭂𓭃𓭄𓭅𓭆𓭇𓭈𓭉𓭊𓭋𓭌𓭍𓭎𓭏𓭐𓭑𓭒𓭓𓭔𓭕𓭖𓭗𓭘𓭙𓭚𓭛𓭜𓭝𓭞𓭟𓭠𓭡𓭢𓭣𓭤𓭥𓭦𓭧𓭨𓭩𓭪𓭫𓭬𓭭𓭮𓭯𓭰𓭱𓭲𓭳𓭴𓭵𓭶𓭷𓭸𓭹𓭺𓭻𓭼𓭽𓭾𓭿𓮀𓮁𓮂𓮃𓮄𓮅𓮆𓮇𓮈𓮉𓮊𓮋𓮌𓮍𓮎𓮏𓮐𓮑𓮒𓮓𓮔𓮕𓮖𓮗𓮘𓮙𓮚𓮛𓮜𓮝𓮞𓮟𓮠𓮡𓮢𓮣𓮤𓮥𓮦𓮧𓮨𓮩𓮪𓮫𓮬𓮭𓮮𓮯𓮰𓮱𓮲𓮳𓮴𓮵𓮶𓮷𓮸𓮹𓮺𓮻𓮼𓮽𓮾𓮿𓯀𓯁𓯂𓯃𓯄𓯅𓯆𓯇𓯈𓯉𓯊𓯋𓯌𓯍𓯎𓯏𓯐𓯑𓯒𓯓𓯔𓯕𓯖𓯗𓯘𓯙𓯚𓯛𓯜𓯝𓯞𓯟𓯠𓯡𓯢𓯣𓯤𓯥𓯦𓯧𓯨𓯩𓯪𓯫𓯬𓯭𓯮𓯯𓯰𓯱𓯲𓯳𓯴𓯵𓯶𓯷𓯸𓯹𓯺𓯻𓯼𓯽𓯾𓯿𓰀𓰁𓰂𓰃𓰄𓰅𓰆𓰇𓰈𓰉𓰊𓰋𓰌𓰍𓰎𓰏𓰐𓰑𓰒𓰓𓰔𓰕𓰖𓰗𓰘𓰙𓰚𓰛𓰜𓰝𓰞𓰟𓰠𓰡𓰢𓰣𓰤𓰥𓰦𓰧𓰨𓰩𓰪𓰫𓰬𓰭𓰮𓰯𓰰𓰱𓰲𓰳𓰴𓰵𓰶𓰷𓰸𓰹𓰺𓰻𓰼𓰽𓰾𓰿𓱀𓱁𓱂𓱃𓱄𓱅𓱆𓱇𓱈𓱉𓱊𓱋𓱌𓱍𓱎𓱏𓱐𓱑𓱒𓱓𓱔𓱕𓱖𓱗𓱘𓱙𓱚𓱛𓱜𓱝𓱞𓱟𓱠𓱡𓱢𓱣𓱤𓱥𓱦𓱧𓱨𓱩𓱪𓱫𓱬𓱭𓱮𓱯𓱰𓱱𓱲𓱳𓱴𓱵𓱶𓱷𓱸𓱹𓱺𓱻𓱼𓱽𓱾𓱿𓲀𓲁𓲂𓲃𓲄𓲅𓲆𓲇𓲈𓲉𓲊𓲋𓲌𓲍𓲎𓲏𓲐𓲑𓲒𓲓𓲔𓲕𓲖𓲗𓲘𓲙𓲚𓲛𓲜𓲝𓲞𓲟𓲠𓲡𓲢𓲣𓲤𓲥𓲦𓲧𓲨𓲩𓲪𓲫𓲬𓲭𓲮𓲯𓲰𓲱𓲲𓲳𓲴𓲵𓲶𓲷𓲸𓲹𓲺𓲻𓲼𓲽𓲾𓲿𓳀𓳁𓳂𓳃𓳄𓳅𓳆𓳇𓳈𓳉𓳊𓳋𓳌𓳍𓳎𓳏𓳐𓳑𓳒𓳓𓳔𓳕𓳖𓳗𓳘𓳙𓳚𓳛𓳜𓳝𓳞𓳟𓳠𓳡𓳢𓳣𓳤𓳥𓳦𓳧𓳨𓳩𓳪𓳫𓳬𓳭𓳮𓳯𓳰𓳱𓳲𓳳𓳴𓳵𓳶𓳷𓳸𓳹𓳺𓳻𓳼𓳽𓳾𓳿𓴀𓴁𓴂𓴃𓴄𓴅𓴆𓴇𓴈𓴉𓴊𓴋𓴌𓴍𓴎𓴏𓴐𓴑𓴒𓴓𓴔𓴕𓴖𓴗𓴘𓴙𓴚𓴛𓴜𓴝𓴞𓴟𓴠𓴡𓴢𓴣𓴤𓴥𓴦𓴧𓴨𓴩𓴪𓴫𓴬𓴭𓴮𓴯𓴰𓴱𓴲 |
|-------|---------------------------|---|

Eg.: LRL 19.10 (𐤀𐤆𐤏𐤋𐤏𐤍𐤏𐤍) = LeLE i.195 = HoSW 145-6.189; Gloss. Gol. 3.4 (AEO I no. 165) (𐤀𐤆𐤏𐤋𐤏𐤍𐤏𐤍) = HoSW 145-6.189; HPBM4 NY r.54 (𐤀𐤆𐤏𐤋𐤏𐤍𐤏𐤍) = HoSW 145-6.189

Cpt.: CrCD 44b; ĆeCED 27; VyDELc 31; WeKH 27

Sem.: see attestations in Period 1 above.

| | | | | | |
|-------|--------------|------------|--------|---------|-------|
| | | 𐤀𐤆𐤏𐤋𐤏𐤍𐤏𐤍 | mAk.hA | | |
| III.8 | back of head | 𐤀𐤆𐤏𐤋𐤏𐤍𐤏𐤍𐤏𐤍 | ↓ | *m'ekhv | 𐤏𐤏𐤏𐤏 |
| | | mkh | mAkḥA | | m'akh |

Eg.: LES 5 1.49 = LeLE i.211; HPBM4 T 2v.9 = LeLE i.211

Cpt.: CrCD 162b; ĆeCED 80; VyDELc 111; WeKH 90

Notes: Coptic: LES 5 1.49 seems to have 𐤀𐤆𐤏𐤋𐤏𐤍^{1.50}<𐤏𐤏>𐤏, but the second 𐤏𐤏 is clearly a dittography induced by the change of line (See also Gardiner's note to the corresponding passage of LES).

| | | | | | |
|-------|------------|------------|--------------|----------|--------------|
| | | 𐤀𐤆𐤏𐤋𐤏𐤍𐤏𐤍𐤏𐤍 | mAk.dU.Ur(ə) | | |
| III.9 | stronghold | 𐤀𐤆𐤏𐤋𐤏𐤍𐤏𐤍𐤏𐤍 | ↓ | *mvkd'ol | 𐤏𐤏𐤏𐤏𐤏𐤏 (B/S) |
| | | mktrt, | mAkduUr(ə) | | məkt'o/o:l |

Eg.: Gloss. Gol. 6.1 (AEO I no. 450) = HoSW 169.224

Cpt.: CrCD 214b; ĆeCED 102; VyDELc 132; WeKH 114

Sem.: see attestations in Period 1 above.

Notes: Hoch spells this word with 𐤏 instead of 𐤏, however in his publication of the text Gardiner (AEO I no. 450) points out that the corresponding hieratic form can stand for both 𐤏 or 𐤏. The parallel Med. Habu 42 (see HoSW 167), where a toponym based on the same Semitic root is spelled 𐤀𐤆𐤏𐤋𐤏𐤍𐤏𐤍, with 𐤏, suggests, I think, that in this case the correct reading is 𐤏, not 𐤏. A reading with 𐤏, however, would not be impossible, and would not be problematic from the point of view of the group writing: simply, the spelling would imply a transcription *mAktUr(ə)* < *mAk.t0.Ur(ə)*, rather than *mAkdUr(ə)* < *mAk.dU.Ur(ə)*.

| | | | | | |
|--------|---------|------|-------|-------|------|
| | | 𐤏𐤏𐤏𐤏 | hA.y0 | | |
| III.10 | husband | hy | ↓ | *h'ey | 𐤏𐤏 |
| | | | hAy | | h'aj |

Eg.: P.Boulaq IV r16.15, r19.15

Cpt.: CrCD 636b; ĆeCED 269; VyDELc 290; WeKH 357

Notes: As in the attestations in Period 2, although the classifiers may vary (𐤏, 𐤏, 𐤏), the phonetic part of the word is consistently written 𐤏𐤏𐤏𐤏.

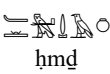
| | | | | | |
|--------|---------|--|------------|----------------------------|------------------|
| III.11 | vinegar |  hmd | hU.m0.d(A) | *h'i:/u:mvd(v) | Ⲫⲏⲙⲕ |
| | | | ↓ | *h'i/umdv < Sem. *ḥumšv | Ⲫⲏⲕ h'e(:)mdǵ |
| | | | hUmǵ(A) | | |

Eg.: Gloss. Gol. 7.7 (AEO I no. 572) = LeLE i.315 = HoSW 228.316

Cpt.: CrCD 682b; CrCD 285; VyDELC 303; WeKH 375

Sem.: see attestations in Period 2 above.

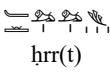
| | | | | | |
|--------|--------|---|----------|--------------|---------|
| III.12 | flower |  hrr(t) | hU.rU.Ur | | Ⲫⲣⲏⲣⲉ |
| | | | ↓ | *ḥvr'i:/u:rv | hr'e:rə |
| | | | hUrUr | | |

Eg.: P.Boulaq IV r5.3

Cpt.: CrCD 704a; ČeCED 294; VyDELC 310; WeKH 388

| | | | | | |
|--------|--------------------------------------|--|-------------|----------------|------------|
| III.13 | commerce, associate, companion |  hbr | hA.bA.(y)r0 | *ḥvb'i:/u:r | Ⲫⲃⲏⲡ |
| | | | ↓ | < Sem. *ḥab'er | ḥvb'i:/u:r |
| | | | hAbAr | | |

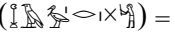
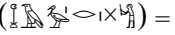
Eg.: HPBM4 L 6v.16 () = LeLE i.354 = HoSW 240.333; LES 5 1.x+24 ()

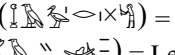
, 2.1 () = LeLE i.354 = HoSW 240.333

Cpt.: CrCD 553a; ČeCED 237; VyDELC 257; WeKH 304

Sem.: *ḥaber – cf. Heb. ḥāber “associate”

| | | | | | |
|--------|--------------------------|---|-------|-----------------|------|
| III.14 | road, street, quarter |  hr | h0.Ur | *h'i:/u:rv | Ⲫⲣ |
| | | | ↓ | < Sem. *ḥur(r)v | h'ir |
| | | | hUr | | |

Eg.: P.Berlin 3053 16.2 = HoSW 247.343

Cpt.: CrCD 696b; ČeCED 291; VyDELC 307; WeKH 384

Sem.: see attestations in Period 1 above.

Notes: The papyrus is dated to the 22nd Dynasty or later (see Trismegistos no. 57094 for references)

| | | | | | |
|--------|-----------------------------|--|-----------------------------------|-------------------------|-------|
| III.15 | veils, thin cloth, purse |  hrd | h ^y 0.U ^r d | | Ⲫⲣⲟⲡ |
| | | | ↓ | *h ₂ 'ord(v) | š'ort |
| | | | h ₂ U ^r d | | |

Eg.: LES 5 2.40 = LeLE i.373 = HoSW 252.353





Cpt.: CrCD 588b; ČeCED 252; VyDELC 270; WeKH 326

| | | | | | |
|--------|----------------|---|----------|-------|-------------|
| III.20 | (palm of) hand |  | k0.Up | *k'op | ⲥⲟⲡ k'op |
| | | | ↓ kUp | | |

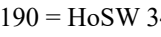
Eg.:  HPBM 4 T 2v.22 = LeLE ii.172 = HoSW 317-8.457
 Cpt.: CrCD 824b; ĆeCED 334; VyDELc 344; WeKH 462
 Sem.: see attestations in Period 2 above.
 Notes: see attestations in Period 2 above.

| | | | | | |
|--------|------------------------|---|--------------|---------|---------------|
| III.21 | violence, injustice |  | gA/U.n0.sA | *g'onsv | ⲥⲟⲛⲘ k'ons |
| | | | ↓ gA/UnsA | | |

Eg.: P.Push. 127 3.6 () = LeLE ii.190 = HoSW 349.512; HPBM4 L 6v.47 () = LeLE ii.190 = HoSW 349.512
 Cpt.: CrCD 822a; ĆeCED 332; VyDELc 342; WeKH 459
 Sem.: no precise parallel can be identified, but Hoch think it may be related with Sem. *√ngś*, cf. Heb. *√ngś* “to press”, “to drive”, “to oppress”; Eth. *nagša* “to reign”, “to wield power”.

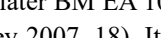
Notes: spelling of P.Push 127 is notoriously bad Caminos 1977, 6, 7n1, so it has to be taken with caution. Moreover, the second sign of the word is partially in a lacuna, and it is therefore impossible to ascertain if it was a  or a . Similarly, the sign  of HPBM4 L 6v.47 may stay for both  or . Overall, therefore, the Egyptian attestations of this word are not conclusive, but it is possible that they fit within the model presented in this study, and therefore are worth being mentioned here. It is also worth noticing that a form  is attested in the later BM EA 10474 8.20, 13.11, 18.17 (Teachings of Amenemope – 26th dyn.; see Laisney 2007, 18). It has however been observed that that papyrus was probably written in an Egyptian dialect ancestor of or related with Coptic Akhmimic (in particular because of the presence of superfluous suffixes .ty added to some verbs, which likely correspond to the verbal suffixes -te so characteristic of Akhmimic Coptic – see Laisney 2007, 18). This is an crucial observation, because in Akhmimic Coptic Egyptian /a/ > ʌ, rather than o, and in fact in Akhmimic the form of this word is ⲥʌⲛⲘ, with ʌ, not ⲥⲟⲛⲘ as in other dialects (see CrCD 822a).

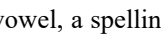
Since ʌ is a *non-back* vowel, a spelling without -w, such as , not only would not be surprising, but it would even been expected in a text written in such a dialect. In fact, this form could indeed be an additional confirmation of the Akhmimic nature of the Egyptian dialect of BM EA 10474.

| | | | | | |
|--------|---------|---|-----------|-------|---------------|
| III.22 | sparrow |  | tA.tA | *t'et | ⲭⲁⲭ dʒ'adʒ |
| | | | ↓ tAtA | | |

Eg.: P.Push. 127 5.1 = LeLE ii.237

Cpt.: CrCD 798b; ĀCED 323; VyDELIC 333; WeKH 441

| | | | | | |
|--------|----------------------------------|--|------------------------|--------------------------------|------------------|
| III.23 | shrine, naos, inner sanctuary |  dbr | dA.bA.r0 ↓ dAbAr | *dvb'i:/u:r < Sem. *dab'i:r | TABIP täb'i:r |
|--------|----------------------------------|--|------------------------|--------------------------------|------------------|

Eg.: Univ.Board v2 (AEO I p.66) = HoSW 376.561

Cpt.: CrCD 400b; ĀCED 183; VyDELIC 211; WeKH 223

Sem.: *dabi:r – cf. Heb. *dabīr* “inner sanctuary”

Appendix B

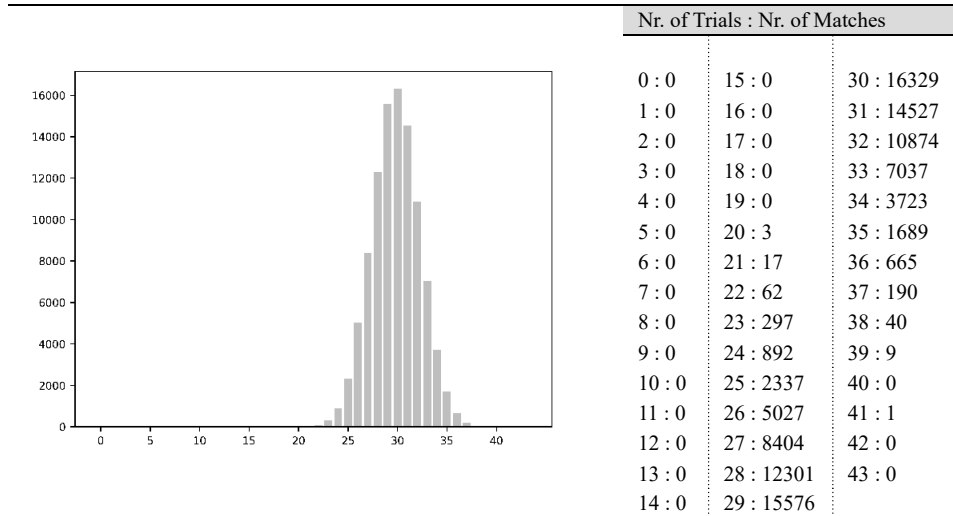

App. B Fig. 1: probabilities of random matches for all disyllabic words.

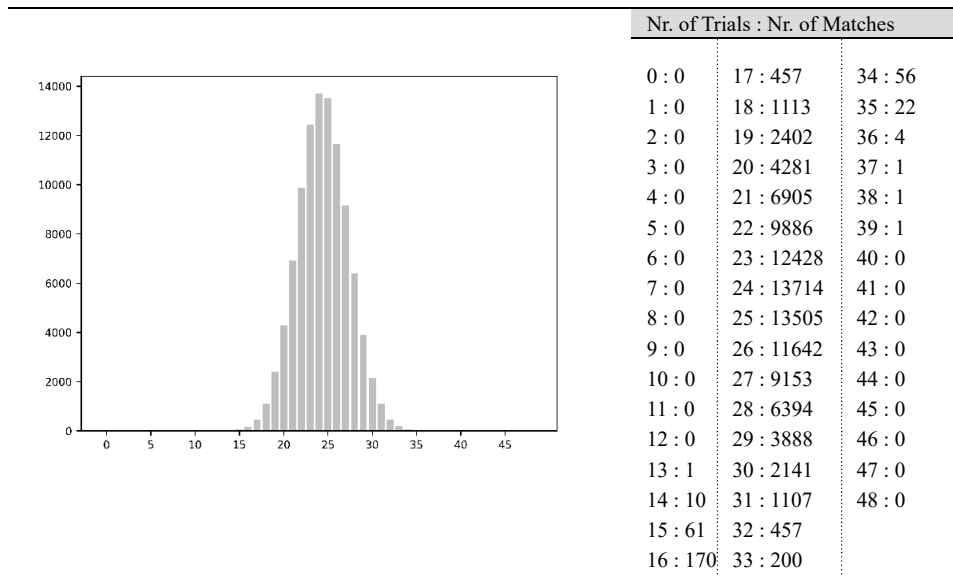

App. B Fig. 2: probabilities of random matches for all trisyllabic words.

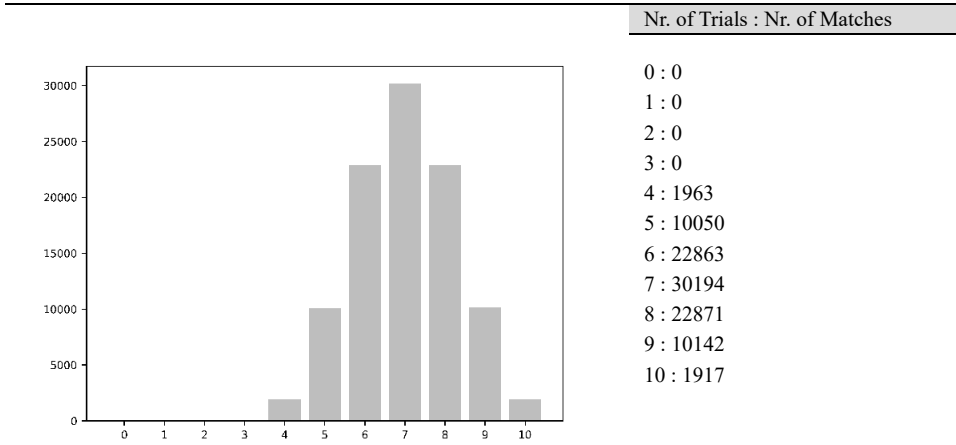

App. B Fig. 3: probabilities of random matches for disyllabic words in Period 1.

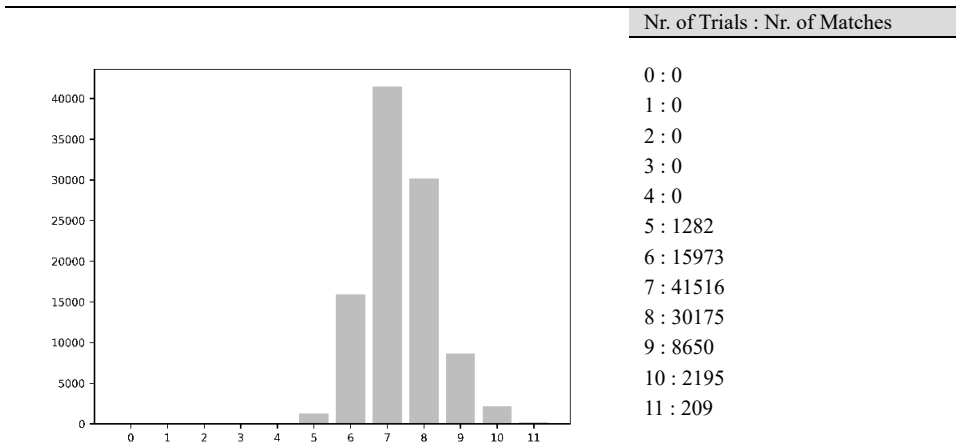

App. B Fig. 4: probabilities of random matches for trisyllabic words in Period 1.

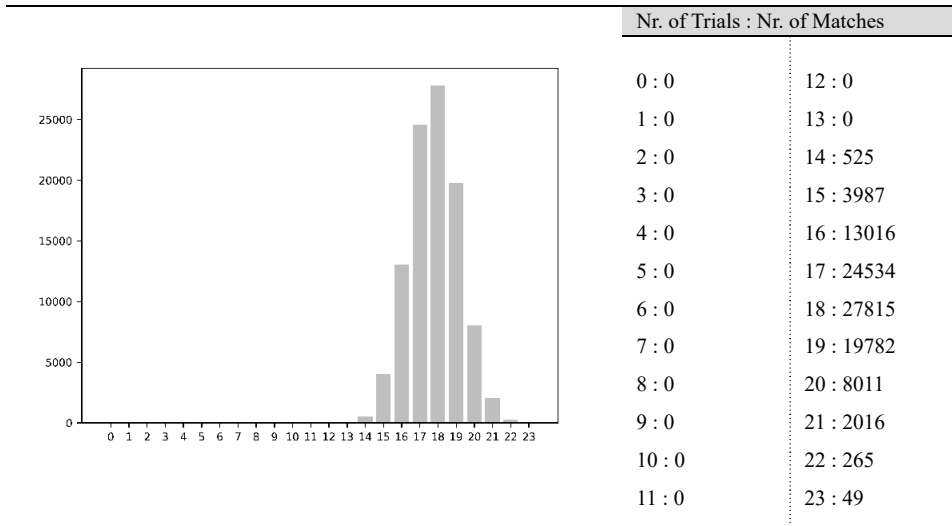

App. B Fig. 5: probabilities of random matches for disyllabic words in Period 2.

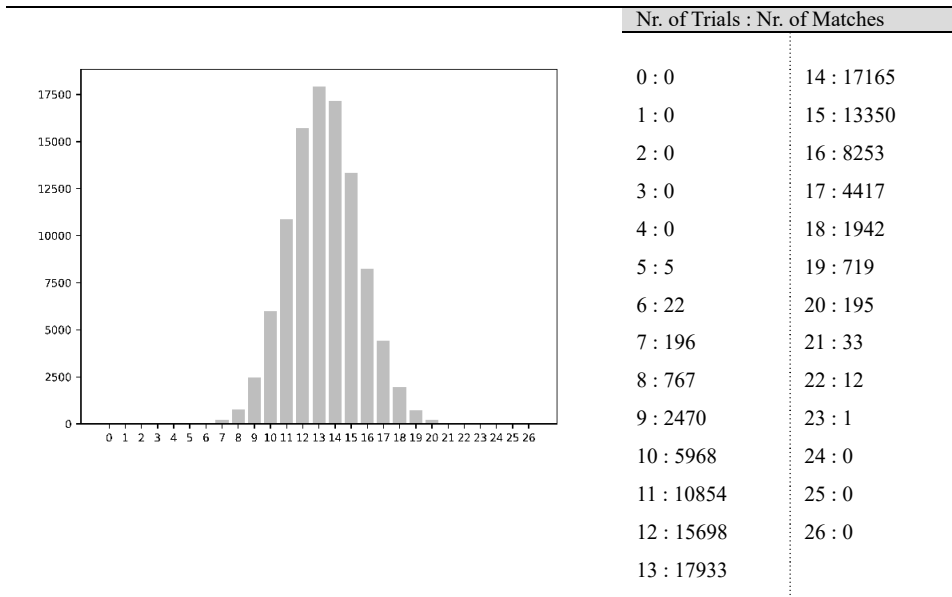

App. B Fig. 6: probabilities of random matches for trisyllabic words in Period 2.

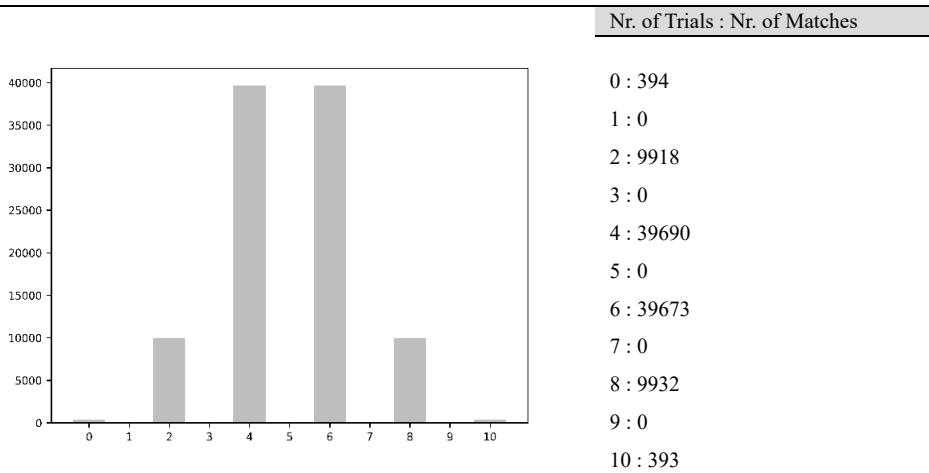

App. B Fig. 7: probabilities of random matches for disyllabic words in Period 3.

Note: the apparently curious distribution of probability is due to the fact that only 10 disyllabic words are attested in Period 3, 5 of which can be reconstructed with a *non-back* vowel, and 5 with a *back* one. This means that if one valid match for a word of vocalic class (*back* or *non-back*) is obtained, then there will always be at least another valid match for a word belonging to the other vocalic class. This means that only an even number of valid matches can be obtained.











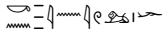
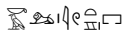
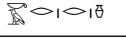

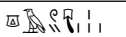

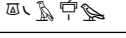
Index of Egyptian words mentioned in the text

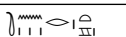
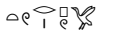
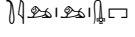

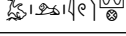

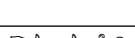
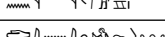
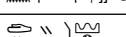

| Word | Transliteration | Translation | Page | Appendix A |
|----------|-----------------|------------------------------------|--------------------------------------|---------------------|
| j | | | | |
| | jyr | stag, ram | 41 | III.1 |
| | jwnw-mnd | Armant | 67 | — |
| | jp | a purple dye-plant, madder | 35 | II.1 |
| | jnb | wall | 91 | — |
| | jrm | a Nubian toponym | 78 | — |
| | jrm' | a toponym | 78 | — |
| | jswt | long plank | 23 | — |
| | jsbt | seat, throne | 5n5 | — |
| | jsdd | Ashdod | 67 | — |
| | jkrt | Ugarit | 48 | — |
| | jkn | a jar | 28, 34 | I.1 |
| | jqd' | maker, builder | 74, 91, 92, 93 | — |
| y | | | | |
| | ym | sea | 28, 31, 34, 41, 47, 51, 95, 96 | I.2; II.2; III.2 |
| | ydf | skilled, knowing, knowledgeable | 68 | — |
| ʕ | | | | |
| | ʕ' | arm, hand | 74, 83 | — |
| | ʕmd | stand firm, hold one's ground | 68, 69 | — |
| | ʕnr | pebble | 24, 26, 38, 40, 56 | II.3; III.3 |
| | ʕnr | stones, rocks, pebbles | 20, 37, 48 | II.4 |
| | ʕršn | lentil | 35, 40, 53, 61 | II.5; III.4 |
| | ʕgrt | wagon, chart | 34 | II.6 |
| | ʕd(d)' | boy | 88 | — |

| w | | | | |
|---|--------------|-----------------------------|---------------------------|-------------------|
| | wr | young bird which cannot fly | 35 | II.7 |
| b | | | | |
| | bŷyt₁ | branch of date-palm | 32 | I.3 |
| | bʳ | ball of eyes | 38, 47, 61 | II.8 |
| | bry | a fish | 31, 34, 41, 48, 51 | I.4; II.9; III.5 |
| | bs | pail, bucket | 32, 35, 53 | I.5; II.11 |
| | bs | God Bes | | II.10 |
| | bš | some fruit, malt | 36, 40, 54 | II.12; III.6 |
| | btʳ < bdt | emmer | 23 | — |
| p | | | | |
| | pr-m(β)ʳ | a toponym | 84 | — |
| | pr | bean | 38, 44 | II.13 |
| | prḥ+w = pUrḥ | to blossom | 49n48 | — |
| | pḏt | archers | 91 | — |
| r | | | | |
| | rb(y) | lioness, she-bear | 37 | II.21 |
| | rʳʳ | a constellation (the Boar?) | 23 | — |
| m | | | | |
| | m(β)ʳ | lion | 74, 84 | — |
| | mjnʳ | herdsman | 74, 85, 86 | — |
| | mnd | God Montu | 67 | — |
| | mrʳ | groom, squire | 76, 77 | — |
| | mrynt | a vessel | 11n13 | — |
| | mrḥ | spear, javelin | 3, 26, 33, 38, 44, 54, 61 | I.6; II.14 |
| | mrkbt | chariot | 2, 28, 34, 39, 42 | I.7; II.15; III.7 |
| | mḥr | basket, box | 22, 38, 50 | II.16 |
| | mḥr | 6th month | 22, 23, 38 | II.17 |
| | mḥmḥwt₁ | flowers (purslane) | 22, 31 | I.8 |
| | mssbt₁ | metal tool | 37 | II.18 |
| | mšddt₁ | comb | 3, 29, 37 | II.19 |

| | | | | |
|----------|-------------|-----------------------------------|--------------------------------------|------------------------|
| | mkr' | merchant(s) | 77 | |
| | mkh | back of head | 40 | III.8 |
| | mktr | stronghold | 29, 31, 34, 42, 52 | I.9; II.20; III.9 |
| | md' < md3w | Medja (troops) | 79 | — |
| n | | | | |
| | nb' | goldsmith | 89 | — |
| | n(t)' | time, return of the year | 74, 86, 87 | — |
| | nt' < nd(j) | flour | 23 | — |
| | nds | little (vessels?) | 91 | — |
| h | | | | |
| | hy | husband | 32, 36, 40, 56, 61 | I.10; II.22; III.10 |
| | hp | law(s) | 33, 38, 56, 61 | I.11; II.23 |
| | hm | fare | 38, 65 | II.24 |
| | hn | hin vessel | 91 | — |
| | hn' | sweetmeats | 73, 81 | — |
| h | | | | |
| | hms' < hmst | to sit | 89, 90 | — |
| | hmd | vinegar | 38, 42, 46, 55 | II.25; III.11 |
| | hrr(t) | flower | 33, 38, 42, 55 | I.12; II.26; III.12 |
| | hrrw(t) | beetle, worm | 33, 49 | I.13 |
| h | | | | |
| | hbr | commerce, associate, companion | 22, 41, 45 | III.13 |
| | hbs | lamp | 22, 39, 48, 49 | II.27 |
| | hpr | to happen | 15, 16 | — |
| | hr | Syrian | 22, 33, 39, 44, 47, 49, 56, 61 | I.15; II.30 |
| | hr | road, street, quarter | 22, 33, 39, 42, 45, 49, 54, 55 | I.14; II.29; III.14 |

| | | | | |
|----------|----------------|--------------------------|----------------------------|--|
| | hṛd | veils, thin cloth, purse | 22, 26, 29, 42 | III.15 |
| | hṛ | tooth, fang | 22, 35 | II.28 |
| | ht | forecourt | 22, 36 | II.31 |
| | htm | fortress, enclosure | 17n23 | — |
| | htn | lettuce, garlic | 22, 36, 45 | II.32 |
| h | | | | |
| | hry-ḥ | subordinate | 83 | — |
| s | | | | |
| | sḥrt | wool, hair | 31, 61 | I.16 |
| | srpt | lotus | 2, 3, 31, 42, 49, 51 | I.17; III.16 |
| | sk(t) | ass's foal | 39 | II.33 |
| | sk' | an officer | 80 | — |
| | st-ḥms' < ḥmst | living room | 89 | — |
| š | | | | |
| | šbd(t) | staffs, rods | 20, 21, 32, 35, 37, 42, 52 | I.18; II.34a; II.34b; II.34c; II.34d; III.17 |
| | šm | father/mother in law | 32 | I.19 |
| | šnft | scale of fish | 27, 32 | I.20 |
| | šḥq | dust | 33, 39, 54, 55 | I.21; II.35 |
| | škrḥ | basket | 36 | II.36 |
| q | | | | |
| | qr' | stormcloud, storm | 74, 90 | — |
| | qrḥ | shield | 32, 43 | I.22 |
| | qrr | stormcloud, storm | 74 | — |
| | qrr | burnt-offering | 36, 41, 53 | II.38; III.18 |
| | qrmt | ashes, cinders, embers | 36, 46 | II.37 |
| | qrt | precious stone | 36 | II.39 |
| | qd | gypsum | 80 | — |
| | qd' | plasterer | 80, 81 | — |
| | qdt | back of hand | 41 | III.19 |

| k | | | | |
|---|-----------|-------------------------------|-------------------|---------------|
|  | kp | (palm of) hand | 28, 40, 42, 47 | II.40; III.20 |
|  | knr | musical instrument (kinnor) | 73 | — |
|  | kr' | prison (?) | 77 | — |
|  | krr | vessel for unguent | 32 | I.23 |
|  | krkr | couch, bed | 32, 35, 51 | I.24; II.41 |
|  | kt | some herb or flower | 100n77 | — |
| g | | | | |
|  | gw | steed | 23 | — |
|  | gwn | hair-cloth, sacking, sack | 35 | II.42 |
|  | gns | violence, injustice | 42 | III.21 |
|  | gsr | finger-ring | 37 | II.43 |
| t | | | | |
|  | t'r | heap, hillock | 15, 36, 43 | II.44 |
|  | trp | goose | 5n4 | — |
|  | trr | oven | 3, 39, 46, 48, 61 | II.45 |
|  | t-sb | God Teshub | 15, 20 | — |
| t | | | | |
|  | tpr | scribe | 68 | — |
|  | tr' | Sile | 71, 72, 78 | — |
|  | trp | goose | 5n4 | — |
|  | ts' < tsy | commander | 74, 91, 92, 93 | — |
|  | tt | sparrow | 39, 40, 48n47, 56 | II.46; III.22 |
| d | | | | |
|  | dbr | shrine, naos, inner sanctuary | 41, 45 | III.23 |
|  | dn' | tired land | 73, 82 | — |
|  | dn' | Danu | 73, 82 | — |
|  | dr | Dor | 69 | — |
|  | dd | amorous, lustful, lascivious | 69 | — |

| | | | | |
|---|---------------------------------|-----------------------|------------|-------------|
|  | dd | Dod, Dud | 69 | — |
| d | | | | |
|  | d' | some part of animals? | 81 | — |
|  | d' < dw | mountain | 73, 87 | — |
|  | d ⁿ r | self-bent rods | 36, 55 | II.47 |
|  | d ⁿ ryt ₁ | scorpion | 33, 39 | I.25; II.48 |
|  | dnh | arm (of oar) | 33 | I.26 |
|  | dhrt | jar, bowl | 39, 44, 49 | II.49 |

Index of groups appearing in the corpus, including variants (Appendix A)

| Group | Transliteration | Words in Appendix A containing the group |
|----------------------|-----------------|--|
| pre-consonant | | |
| | -rC | I.4; I.6; I.7; I.17; I.22; II.3; II.4; II.5; II.6; II.7; II.9; II.13; II.14; II.15; II.16; II.20; II.35 (misspelling?); II.37; II.41; II.47; II.49; III.1; III.3; III.4; III.7; III.13; III.15; III.16; III.23; see §4.3 |
| | -nC | I.2; I.25; II.3; II.4; II.8; II.28; II.44; II.47; II.48; III.3; see §4.3 |
| j | | |
| | jA | I.1 |
| | jA | II.13; II.48 (misspelling?); III.1 |
| | jA | II.1 |
| | 'U / U' | See §12.2 |
| y | | |
| | yA | I.2; I.3; I.4; I.10; I.25; II.2; II.9; II.13; II.21; II.22; II.48; III.10; III.17 |
| | yU / Uy | III.1; III.2; III.5 |
| ʕ | | |
| | ʕA | I.3; I.16; I.22; II.3; II.4; II.5; II.36; III.3; III.4 |
| | ʕA | II.6 |
| | ʕU / Uʕ | II.3 |
| w | | |
| | wA | I.8 |
| | wA | II.7; II.42 |
| b | | |
| | bA | I.18; II.34a; II.34b; II.34d; III.17 |
| | bA | I.4; I.5; II.9; II.10; II.11; II.12; III.5; III.13 |
| | bA | I.3; II.12; III.6; III.13; III.23 |
| | bU / Ub | I.7; II.8; II.15; II.18; II.21; II.27; II.34c; III.7 |
| p | | |
| | pA | I.11 |
| | pA | I.17; II.1 |
| | pU / Up | I.11; II.13; II.23; II.40; III.16; III.20 |

| | | |
|----------|---------|---|
| f | | |
| | fA | I.20 |
| m | | |
| | mA | I.19 |
| | mA | I.2; I.6; I.7; I.8; II.2; II.14; II.15; II.16; II.17; II.18; II.19; II.25; II.37; III.2; III.7; III.11 |
| | mU / Um | II.24 |
| | mAk | I.9; II.20; III.8; III.9 |
| n | | |
| | nA | I.20 |
| | nA | I.1; I.26; II.5; II.32; II.42; III.4; III.21 |
| | nU | See §12.2 |
| | nA (?) | III.21 |
| r | | |
| | rA | II.21 |
| | rA | I.9; I.16; I.22; I.23; I.24; II.3; II.4; II.6; II.8; II.28; II.36; II.38; II.39; II.41; II.44; II.47; II.48; III.13; III.18 |
| | rU / Ur | I.12; I.13; I.14; I.15; I.25; II.3; II.4; II.16; II.17; II.26; II.29; II.30; II.43; II.45; II.48; III.5; III.7; III.9; III.12; III.14; III.15 |
| | rU / Ur | I.13 |
| h | | |
| | hA | I.11 |
| | hA | I.10; II.22; II.23; II.24; III.10 |
| | hU / Uh | I.11 |
| ḥ | | |
| | ḥA | I.13 |
| | ḥA | III.8 |
| | ḥU / Uḥ | I.6; I.12; I.21; I.26; II.14; II.25; II.26; II.35; II.49; III.11; III.12 |
| ḥ | | |
| | ḥA | II.28; III.13 |
| | ḥA | I.8; I.14; I.15; II.17; II.27; II.29; II.30; II.31; III.13; III.14 |
| | ḥ2A | II.16; II.17; II.28; II.32; III.15 |
| s | | |

| | | |
|--------|----------------|--|
| 𐎧 | sA | III.16 |
| 𐎦 | sA | I.5; I.16; [I.17]; II.10; II.11; II.18; II.27; II.33; II.43; III.21 |
| 𐎦𐎥 | sU / Us | II.18 |
| 𐎧 | | |
| 𐎧 / 𐎧𐎡 | šA | I.18; I.19; I.20; I.21; II.5; II.12; II.19; II.34a; II.34b; II.34c; II.34d; II.35; II.36; III.4; III.6; III.17 |
| q | | |
| 𐎧𐎡 | qA | I.21; I.22; II.35; II.37; II.38; II.39; III.18; III.19 |
| k | | |
| 𐎧 | kA | I.7; I.23; II.15; II.36; II.40; II.41; III.7; III.20 |
| 𐎧 / 𐎧 | kU | I.1; I.24 |
| 𐎧 | kU | II.33 |
| g | | |
| 𐎧𐎡 | gA | II.6; II.42; II.43; III.9 |
| 𐎧 | gA ? gU / Ug ? | III.21 |
| t | | |
| 𐎧 | tA | I.9; II.44 |
| 𐎧 | tA | I.7; I.16; I.17; II.6; II.15; II.20; II.31; II.34c; II.37; II.39; II.45; II.49; III.7; III.16 |
| 𐎧𐎡 | tA | II.44 |
| 𐎧 | tA | II.45 |
| t̄ | | |
| 𐎧 | t̄A | II.32; II.46; III.22 |
| 𐎧 | t̄U / Ut̄ | II.46 |
| d | | |
| 𐎧 | dA | I.18; II.34a; II.34d; III.23; III.15 |
| 𐎧 | dU / Ud | II.19; II.34c; III.15; III.17; see §11 |
| 𐎧 | dU / Ud | II.34b |
| d̄ | | |
| 𐎧 | d̄A | II.25 |
| 𐎧 | d̄A | I.25; I.26; II.47; II.48; II.49; III.11; III.19 |

Lingua Aegyptia – Studia Monographica

Recent Publications and Backlist

ISSN: 0946-8641

*Éléments de la terminologie du temps
en égyptien ancien*

Gaëlle Chantrain

This book has a double scope: first, bringing a contribution to the knowledge and understanding of the time conceptions in Ancient Egypt through a lexical study and, second, contributing to the definition of a methodological frame for lexical semantics in Ancient Egyptian.

In the introduction, the reader will first find a state of the art from the point of view of time-related studies in Egyptology, lexical semantics studies, and classifiers studies. The next introductory sections deal with the links between time, space and motion, with the complexity of time conceptions in Ancient Egypt, and with the impact of this plural vision on the lexicon.

The first part of the core study aims at establishing a proposition of canvas for the semasiology of nouns. It also presents the semasiological analysis of eight lexemes belonging to the UNBOUNDED TIME domain: *3.t* (moment), *wmw.t* (hour), *mw* (moment), *tr* (time), *h3w* (epoch), *rk* (epoch), *ḥꜥw* (lifetime) and *hnty* (period).

The second part is dedicated to the onomasiology of the UNBOUNDED TIME domain, as well as some of its connections with some contiguous domains like SPACE.

Lingua Aegyptia –
Studia Monographica 21
Hamburg 2020, paperback,
xxxiv+344 pages
(illustrations)
French text
ISSN: 0946-8641
ISBN: 978-3-943955-21-7

€ 59 (subscribers' price: € 49)
(incl. 7% German VAT, excl. shipping)

Send your order to
orders@widmaier-verlag.de
or visit www.widmaier-verlag.de

North American customers may also
contact the official distributor ISD
(www.isdistribution.com)

CONTENTS

| | |
|--|--|
| 0.1 État de la question | II.5 <i>h3w</i> |
| 0.2 Objectifs de la présente étude | II.6 <i>rk</i> |
| Partie I : Notions théoriques | II.7 <i>ḥꜥw</i> |
| I.1 Définitions | II.8 <i>hnty</i> |
| I.2 Temps, espace et mouvement | II.9 Récapitulatif des sémèmes identifiés. |
| I.3 Le temps en Égypte ancienne : une conception plurielle | Partie III : Onomasiologie |
| I.4 Corpus | III.1 Définition des significations-types |
| I.5 Méthodologie | III.2 Oppositions structurelles au sein du réseau sémantique |
| Partie II : Sémasiologie | III.3 Organisation du sens |
| II.0 Introduction aux analyses de sémasiologie | IV Conclusions |
| II.1 <i>3.t</i> | Liste des abréviations employées |
| II.2 <i>wmw.t</i> | Bibliographie |
| II.3 <i>mw</i> | Index des passages cités |
| II.4 <i>tr</i> | |

Lingua Aegyptia – Studia Monographica

ISSN: 0946-8641

- 1 Frank Kammerzell, *Panther, Löwe und Sprachentwicklung im Neolithikum*.
1994 (hardcover, 100 pages), out of print
- 2 Gerald Moers (ed.), *Definitely: Egyptian Literature: Proceedings of the symposion "Ancient Egyptian literature: history and forms"*, Los Angeles, March 24–26, 1995.
1999 (hardcover, X+142 pages), out of print
- 3 Dörte Borchers, Frank Kammerzell & Stefan Weninger (eds.), *Hieroglyphen – Alphabete – Schriftreformen: Studien zu Multiliteralismus, Schriftwechsel und Orthographieneuregelungen*.
2001 (hardcover, VI+270 pages), €49, now € 30
- 4 Stephan Jäger, *Altägyptische Berufstypologien*.
2004 (hardcover, X+340+xlvi+XCIV pages), €79, now € 45
- 5 José M. Galán, *Four Journeys in Ancient Egyptian Literature*.
2005 (hardcover, V+186 pages), out of print
- 6 Anthony Spalinger, *Five Views on Egypt*.
2006 (hardcover, VIII+176 pages), out of print (PDF online)
- 7 H.J. Polotsky, *Scripta Posteriora on Egyptian and Coptic*,
edited by Verena M. Lepper & Leo Depuydt.
2007 (hardcover, VI+230 pages), €49, now € 35
- 8 Petra Andrassy, Julia Budka & Frank Kammerzell (eds.), *Non-Textual Marking Systems, Writing and Pseudo Script from Prehistory to Modern Times*.
2009 (hardcover, VIII+312 pages), out of print (PDF online)
- 9 Eitan Grossman, Stéphane Polis & Jean Winand (eds.),
Lexical Semantics in Ancient Egyptian.
2012 (hardcover, vi+490 pages), € 69 (subscribers' price: € 59)
ISBN: 978-3-943955-09-5
- 10 R.B. Parkinson,
The Tale of the Eloquent Peasant: A Reader's Commentary.
2012 (hardcover, xii+384 pages), € 59 (subscribers' price: € 49)
ISBN: 978-3-943955-10-1
- 11 Gerald Moers, Kai Widmaier, Antonia Giewekemeyer, Arndt Lümers & Ralf Ernst (eds.),
Dating Egyptian Literary Texts.
"Dating Egyptian Literary Texts" Göttingen, 9–12 June 2010, Volume 1
2013 (hardcover, xiv+653 pages), € 95 (subscribers' price: € 79)
ISBN: 978-3-943955-11-8

- 12 Andréas Stauder,
Linguistic Dating of Middle Egyptian Literary Texts.
 “Dating Egyptian Literary Texts” Göttingen, 9–12 June 2010, Volume 2
 2013 (hardcover, xx+568 pages), € 85 (subscribers’ price: € 69)
 ISBN: 978-3-943955-12-5
- 13 Marc Brose,
Grammatik der dokumentarischen Texte des Mittleren Reiches.
 2014 (cloth, xx+553 pages), € 85 (subscribers’ price: € 69)
 ISBN: 978-3-943955-13-2
- 14 Andréas Stauder,
The Earlier Egyptian Passive. Voice and Perspective.
 2014 (cloth, xviii+448 pages), € 69 (subscribers’ price: € 59)
 ISBN: 978-3-943955-14-9
- 15 Eitan Grossman, Stéphane Polis, Andréas Stauder & Jean Winand (eds.),
On Forms and Functions: Studies in Ancient Egyptian Grammar.
 2014 (cloth, vi+366 pages), € 59 (subscribers’ price: € 49)
 ISBN: 978-3-943955-15-6
- 16 Julia Budka, Frank Kammerzell & Sławomir Rzepka (eds.),
Non-Textual Marking Systems in Ancient Egypt (and Elsewhere).
 2015 (cloth, x+322 pages), € 59 (subscribers’ price: € 49)
 ISBN: 978-3-943955-16-3
- 17 Eitan Grossman, Peter Dils, Tonio Sebastian Richter & Wolfgang Schenkel (eds.),
*Greek Influence on Egyptian-Coptic: Contact-Induced Change in an Ancient African
 Language.* DDGLC Working Papers 1
 2017 (cloth, viii+534 pages), € 89 (subscribers’ price: € 69)
 ISBN: 978-3-943955-17-0
- 18 Kristina Hutter,
*Das sdm=f-Paradigma im Mittl ägyptischen: Eine Vergleichsstudie verschiedener
 Grammatiken.*
 2017 (paperback, x+289 pages, incl. 47 tables), € 49 (subscribers’ price: € 39)
 ISBN: 978-3-943955-18-7
- 18 Gaëlle Chantrain & Jean Winand (eds.),
Time and Space at Issue in Ancient Egypt.
 2018 (paperback, viii+242 p.), € 55 (subscribers’ price: € 39)
 ISBN: 978-3-943955-19-4

All prices include German VAT (7%).

For orders, standing orders and further information:

www.widmaier-verlag.de
orders@widmaier-verlag.de

North American customers may also contact the official distributor ISD
 (for issues since volume 9):

www.isdistribution.com