

DEUTSCHES ELEKTRONEN-SYNCHROTRON DESY

DESY 76/50
September 1976



Observation of Associated K_S^0 -Electron Production in e^+e^- Annihilation

by

PLUTO-Collaboration

H. Burmeister, U. Greife, H. G. Döhr, K. Derikum, R. Devenish, J. D. Fox,
G. Franke, G. Hügge, Ch. Kerke, G. Korbitz, Th. Kahl, G. Kries, M. Küster,
S. Kwon, R. Schmitz, H. V. Ranga Swamy, U. Grimm, H. Jahl, P. Motzner,
G. G. Winter and W. Zimmermann
Deutsches Elektronen-Synchrotron DESY, Hamburg

V. Blobel, H. Jensing, B. Koppitz, E. Lohrmann
II. Institut für Experimentalphysik der Universität Hamburg

A. Bäcker, J. Bürger, C. Grupen, M. Rost
Gesamthochschule Siegen

H. Meyer, K. Wacker
Gesamthochschule Wuppertal

2 HAMBURG 52 · NOTKESTIEG 1

To be sure that your preprints are promptly included in the
HIGH ENERGY PHYSICS INDEX ,
send them to the following address (if possible by air mail) :

DESY
Bibliothek
2 Hamburg 52
Notkestieg 1
Germany

OBSERVATION OF ASSOCIATED K_S^0 -ELECTRON PRODUCTION IN e^+e^- ANNIHILATION

PLUTO-Collaboration

J. Burmester, L. Criegee, H. C. Dehne, K. Derikum, R. Devenish, J. D. Fox,
G. Franke, G. Flügge, Ch. Gerke, G. Horlitz, Th. Kahl, G. Knies, M. Rößler,
S. Wolff, R. Schmitz, T. N. Ranga Swamy⁺, U. Timm, H. Wahl⁺⁺, P. Waloschek,
G. G. Winter, W. Zimmermann

Deutsches Elektronen-Synchrotron DESY, Hamburg

V. Blobel, H. Jensing, B. Koppitz, E. Lohrmann

II. Institut für Experimentalphysik der Universität Hamburg

A. Bäcker, J. Bürger, C. Grupen, M. Rost
Gesamthochschule Siegen

H. Meyer, K. Wacker
Gesamthochschule Wuppertal

ABSTRACT:

We have observed K_S^0 production in e^+e^- annihilation between 3.6 and 4.4 GeV CMS energy. In the 4.0-4.1 GeV range K_S^0 mesons occur correlated with prompt electrons, indicating the formation and weak decay of charmed particles. Within the sensitivity of the experiment, no K_S^0 -electron correlation is seen at 3.6 and around 4.4 GeV.

⁺ now at Tata Institute, Bombay, India

⁺⁺ on leave from CERN, Geneva, Switzerland

In a search for semileptonic decays of charmed particles¹⁾ we have scanned e^+e^- annihilation events for specific decay products, in particular K_S^0 mesons and electrons. The measurements were made with the magnetic detector PLUTO at the e^+e^- -storage ring DORIS. Fig.1 shows a cross section of the detector. It has 14 cylindrical proportional wire chambers. The superconducting coil produces a 2 T magnetic field parallel to the beam axis. The usable magnetic volume is 1.4 m diameter x 1.05 m length. The detector contains two cylindrical lead converters, whose radii and thicknesses are 37.5 cm, 0.44 R.L. and 59.4 cm, 1.7 R.L. respectively. Wire chambers behind these converters allow the identification of electrons and photons. The detector is triggered by a logic combination of signals from the proportional wire chambers. This is done in two steps of hardware logic in which track elements are recognized both before the lead converters and behind them. Events are accepted if they satisfy one of the following conditions: (i) at least two tracks before the lead, with their azimuth angles not belonging to two adjacent 45° sectors, (ii) at least three track elements after one of the lead converters, (iii) two track elements after the second lead converter, if they are coplanar within $\pm 13.5^\circ$. The momentum cut-off for tracks recognized by the trigger is 240 MeV/c. The solid angle for track recognition and for the trigger is 86% of 4π . Further details have been described in other publications.³⁾ The luminosity is monitored by small angle (130 mrad) e^+e^- scattering. Data were taken at the CMS energies 3.6, 4.0-4.3, and around 4.4 GeV with integrated luminosities of 270, 840, and 770 nb^{-1} respectively.²⁾

In order to obtain a sample enriched with K_S^0 mesons we selected events which satisfy the following criteria: (i) Two tracks of opposite charge have a minimum distance (geometrical average) of 5 mm from the beam-beam interaction point, (ii) the reconstructed flight path of the parent particle meets the interaction point within certain bounds, (iii) there is at least one additional track.

The invariant two-particle mass of all events satisfying these criteria is shown in Figs.2a-2c. A clear signal from the decay $K_S^0 \rightarrow \pi^+\pi^-$ is seen at all three energies. Because of the short decay length of the K_S^0 there is a considerable background of normal hadronic events which accidentally meet the above criteria due to the finite resolution of the track reconstruction. The K_S^0 detection efficiency in the $\pi^+\pi^-$ decay mode as determined by Monte Carlo calculations rises slowly with momentum, and averages 20% for the observed events. The numbers of K_S^0 events indicate that the cross section for K_S^0 production increases with

CMS energy between 3.6 and 4.4 GeV.

The K_S^0 event sample was then investigated for associated electrons. Electrons were identified by counting wire signals in the two proportional chambers following the thick (1.7 R.L.) lead converter of the detector. To be considered an electron candidate a track must (i) come from the interaction point and hit the converter ($|\cos\theta| \leq .55$) and (ii) have a momentum greater than 300 MeV/c. A candidate is counted as an electron, if it produces more than 10 wire signals inside a certain fiducial volume centered around the interaction of the track with the chambers, otherwise it is considered a hadron. If a second track produces signals inside the fiducial volume, the electron candidate is rejected. The efficiency for electrons to produce more than 10 wire signals was measured with the help of electrons from converted photons. It depends slightly on electron momentum, and averages 50% for electron momenta between 300 MeV/c and 1 GeV/c. The probability that a hadron simulates the signature of an electron was measured using multihadron decays of the J/ψ (3.1), and found to be not larger than 3%.

The result of this search is given by the number of identified electrons divided by the number of hadron tracks inside the electron acceptance ((i)-(ii) above). Fig.2e shows this e/hadron ratio as a function of the invariant mass of the associated two pion system for the energy region 4.0-4.3 GeV. There is an enhancement at the K^0 mass, indicating a strong K_S^0 -electron correlation, over a rather uniform background outside.

Such a background can be produced by the following sources:

(i) hadrons interacting in the lead converter, (ii) accidental overlap between a hadron track and a photon shower, (iii) electrons coming from very asymmetric Dalitz pairs or e^+e^- pairs originating in the beam pipe, (iv) photons producing Compton electrons, and (v) radiative processes leading to a J/ψ (3.1) $\pi^+\pi^-$ final state with the subsequent decay J/ψ (3.1) $\rightarrow e^+e^-$. Type (v) events were eliminated by visual inspection. The contribution of all other background sources was checked by measuring the electron/hadron ratio in a random sample of multihadron events (≥ 3 tracks). For events taken between 4.0 and 4.3 GeV we obtain the ratio $3.7 \pm 0.6\%$, indicated by the shaded area in Figs.2d-2f. Within errors this value is consistent with the ratio outside the K^0 mass band at all three energies. We have checked the possibility that the $K_S^0 e$ events are simulated by a correlated $K_S^0 \gamma (K_S^0 \pi^0)$ production via background mechanism

(iii) by searching for photons converted into fully detectable pairs. The contribution is negligible, < 0.7 events at 90% C.L. The e^+e^- ratio at the K^0 peak is consistent with one.

In contrast to the energy region 4.0-4.3 GeV, the measurements at 3.6 and around 4.4 GeV show no significant K_S^0 -electron correlation (Figs.2d, 2f). Fig.3 shows the energy dependence of the visible cross section for $K_S^0 e$ production (with decay $\rightarrow \pi^+\pi^-$), calculated by using all events from the mass bin $0.46 < m_{\pi\pi} < 0.54$ GeV/c². The cross section peaks markedly around $\sqrt{s} = 4.05$ GeV. Subtracting background and accounting for acceptance, branching ratio, and unobserved K_L^0 mesons, we estimate the inclusive cross section at the peak as

$$\sigma(e^+e^- \rightarrow e^\pm K^0 + \text{anything}) = 3 \text{ nb.}$$

Systematic uncertainties of this estimate may well amount to a factor of two. We observe a multiplicity of 2.5 extra charged particles associated with the $K_S^0 e$ events. The raw electron spectrum contains mainly small momenta (< 700 MeV/c), in qualitative agreement with other semiinclusive electron measurements.⁴⁾

In conclusion, we have observed a signal of correlated electrons and K_S^0 mesons at CMS energies above 4.0 GeV. We consider this strong evidence for the weak decay of a particle of a mass between 1.8 and 2.0 GeV, assuming associated production. The simultaneous occurrence of a strange particle in the decay is highly suggestive of the new quantum number charm.¹⁾ Similar conclusions have been drawn from the observation of an exotic $K\pi\pi$ state⁵⁾ and of prompt electrons⁴⁾ in e^+e^- collisions. $K_S^0 e$ events have also been observed in ν bubble chamber experiments.^{6,7)} The energy dependence of the cross section argues against the possibility that the $K_S^0 e$ events originate from the decays of heavy leptons.⁸⁾ In addition, the observed charged multiplicity is inconsistent with the low value expected for heavy lepton decays.⁹⁾

ACKNOWLEDGEMENTS

The competent operation of the storage ring by Dr. D. Degele and his group is gratefully acknowledged. We are indebted to H. Ahrens, R. Cyriacks, B. Eichhorn, K. Finke, H. Kock, W. Kuffner, A. Marxen, W. Mehrgardt, H. Schultz, and A. Stüben for their excellent work in the construction and maintenance of the detector. We thank Dr. H. G. Fischer of CERN for his help and advice during the early checkout period. We also thank the members of the cryogenic groups for their very efficient service.

REFERENCES

- 1) S. L. Glashow, J. Iliopoulos, and L. Maiani; Phys. Rev. D2, (1970) 1285
M. K. Gaillard, B. W. Lee, and J. L. Rosner; Rev. Mod. Phys. 47 (1975) 277
- 2) A preliminary version of these results has been communicated at the Tbilisi Conference 1976
- 3) L. Criegee et al., Proc. 1973 Int. Conf. on Instrumentation for High Energy Physics, 707 (1973)
E. Lohrmann, Journal de Physique, 37, Coll. C-2, (1976) 15
- 4) W. Braunschweig et al., DESY 76/37, to be publ. in Phys. Letters
- 5) I. Peruzzi et al., Phys. Rev. Lett. 37 (1976) 569
G. Goldhaber et al., Phys. Rev. Lett. 37 (1976) 255
- 6) J. von Krogh et al., Phys. Rev. Lett. 36 (1976) 710
- 7) J. Blietschav et al., Phys. Lett. 60B (1976) 207
H. Deden et al., Phys. Lett. 58B (1975) 361
- 8) M. L. Perl et al., Phys. Rev. Lett. 35 (1975) 1489
- 9) Y.-S. Tsai; Phys. Rev. D4 (1971) 2821.

FIGURE CAPTIONS

- 1) Detector PLUTO viewed along the beam.
- 2) Upper histograms: Invariant mass plots of selected $\pi\text{-}\pi$ pairs for three different CMS energies with hand-drawn background curves. Lower histograms: e/hadron ratio associated with the $\pi\text{-}\pi$ pairs plotted above. Shaded area: e/hadron ratio of a random sample of multiprong events.
- 3) Visible cross section for associated $K_S^0 e$ production versus CMS energy. Background is included.

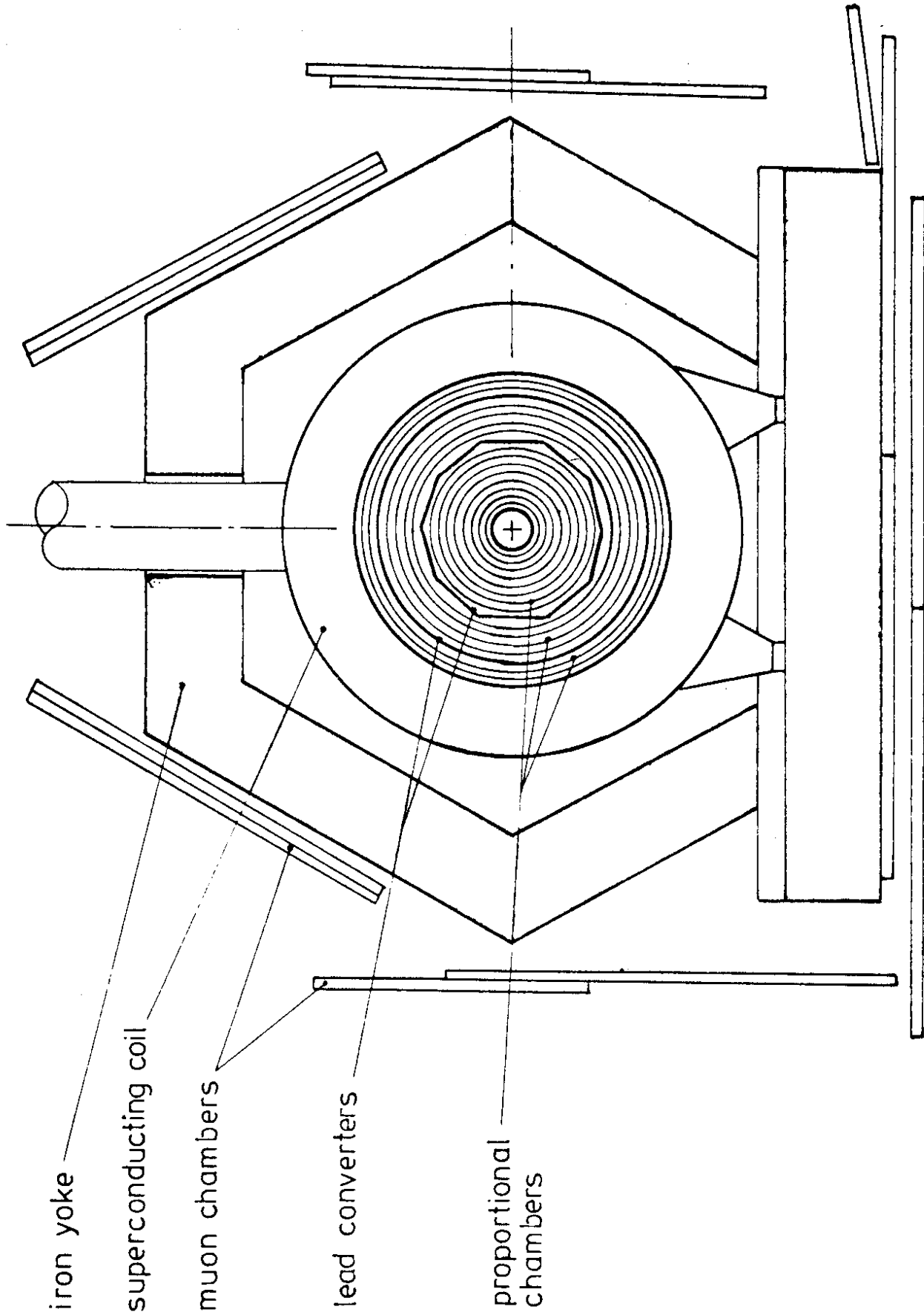

Fig. 1

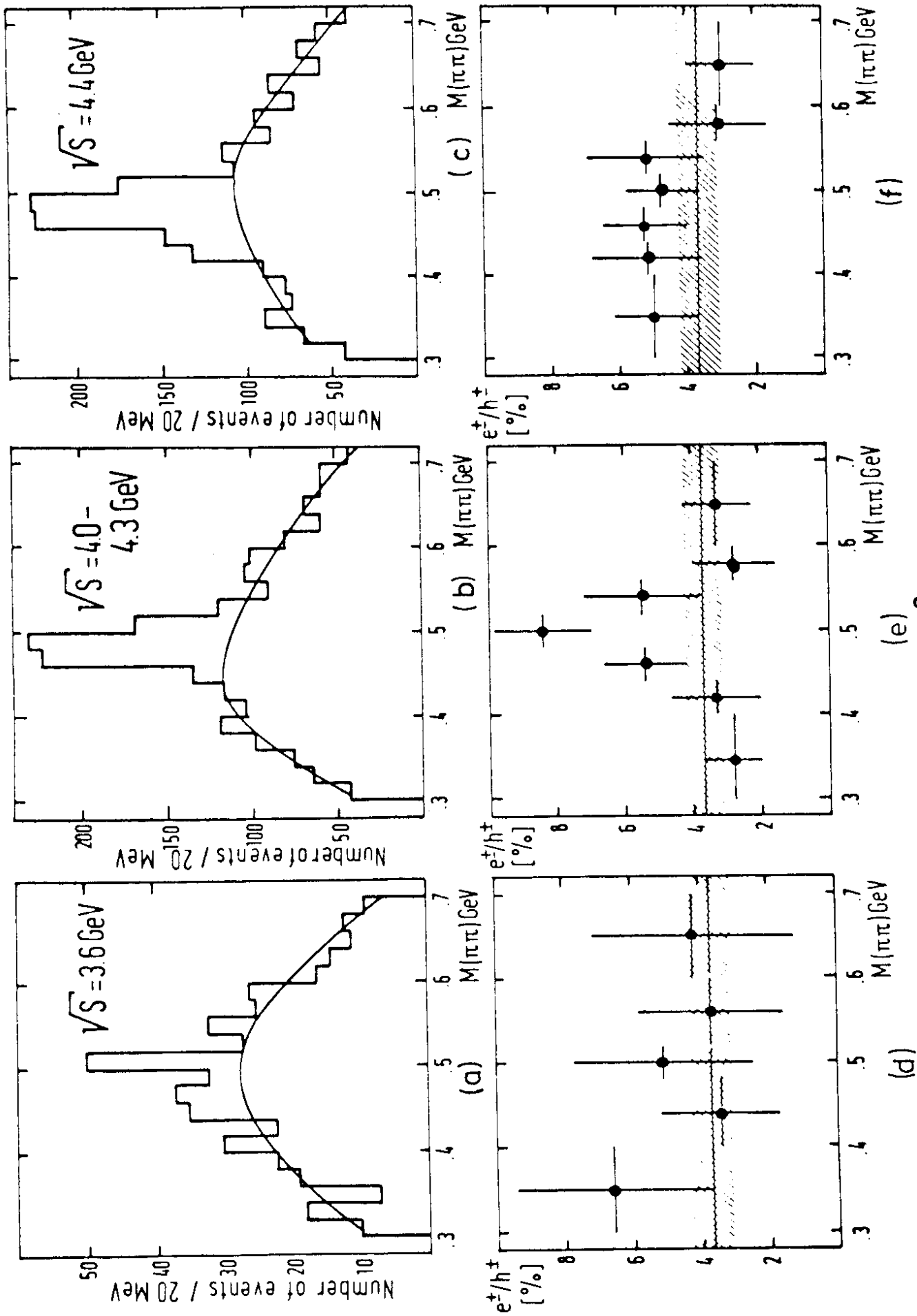

Fig. 2

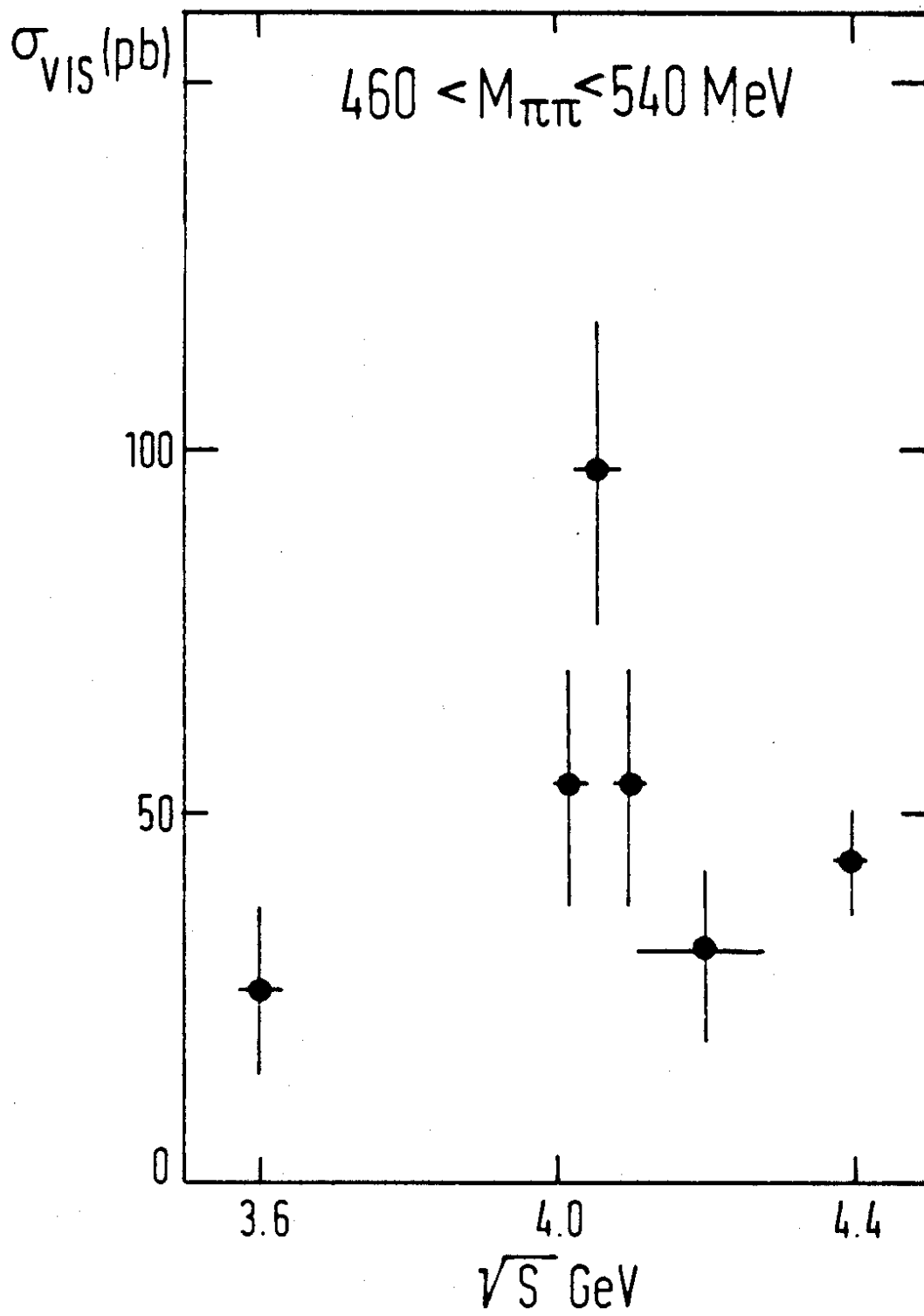

Fig. 3