



# **Fisheries Centre Research Reports**

---

*2002 Volume 10 Number 2*

## **The Use of Ecosystem Models to Investigate Multispecies Management Strategies for Capture Fisheries**

ISSN 1198-6727

The Use of Ecosystem Models to Investigate  
Multispecies Management Strategies  
for Capture Fisheries

*Fisheries Centre Research Reports*  
2002 Volume 10 Number 2

*edited by*

*Tony Pitcher and Kevern Cochrane*

*156 pages © published by*

*The Fisheries Centre, University of British  
Columbia*

*2204 Main Mall  
Vancouver, B.C., Canada  
2002*

*ISSN 1198-6727*

# THE USE OF ECOSYSTEM MODELS TO INVESTIGATE MULTISPECIES MANAGEMENT STRATEGIES FOR CAPTURE FISHERIES

Edited by

Tony Pitcher and Kevern Cochrane

2002

*Fisheries Centre Research Reports 10(2), 156pp*

## CONTENTS

	Page
<b>Directors Foreword</b> <i>Ecosim and the Land of Cockayne</i> .....	3
<b>Executive Summary</b> .....	4
<b>Introduction</b>	
The Use of Ecosystem Models to Investigate Ecosystem-Based Management Strategies for Capture Fisheries: Introduction <i>Kevern Cochrane</i> .....	5
Searching for Optimum Fishing Strategies for Fishery Development, Recovery and Sustainability <i>Carl J. Walters, V. Christensen and Daniel Pauly</i> .....	11
<b>Contributed Papers</b>	
Simulating Fisheries Management Strategies in the Strait of Georgia Ecosystem using Ecopath and Ecosim <i>Steven J. D. Martell, Alasdair I. Beattie, Carl J. Walters, Tarun Nayar and Robyn Briese</i> .....	16
The Use of Ecosystem-based Modelling to Investigate Multi-species Management Strategies for Capture Fisheries in the Bali Strait, Indonesia <i>Eny Anggraini Buchary, Jackie Alder, Subhat Nurhakim and Tonny Wagey</i> .....	24
The Eastern Bering Sea <i>Kerim Aydin</i> .....	33
A Preliminary North-East Atlantic Marine Ecosystem Model: the Faroe Islands and ICES Area Vb <i>Dirk Zeller and Katia Freire</i> .....	39
Policy Simulation of Fisheries in the Hong Kong Marine Ecosystem <i>Wai-Lung Cheung, Reg Watson and Tony Pitcher</i> .....	46
Exploration of Management and Conservation Strategies for the Multispecies Fisheries of Lake Malawi using an Ecosystem Modelling Approach <i>Edward Nsiku</i> .....	54
The Use of Ecosim to Investigate Multispecies Harvesting Strategies for Capture Fisheries of the Newfoundland-Labrador Shelf <i>Marcelo Vasconcellos, Johanna Heymans and Alida Bundy</i> .....	68
Simulating Management Options for the North Sea in the 1880s <i>Steven Mackinson</i> .....	73
Ecosim Case Study: Port Phillip Bay, Australia <i>Beth Fulton and Tony Smith</i> .....	83

Simulating Extreme Fishing Policies in Prince William Sound, Alaska: a preliminary evaluation of an ecosystem-based policy analysis tool <i>Thomas A. Okey</i> .....	94
Exploring Alternative Management Policies: A Preliminary Ecological Approach for the San Matias Gulf Fishery, Argentina <i>Villarino María Fernanda, Mario L. Lasta and Marcelo Pájaro</i> .....	109
Exploring Multispecies Harvesting Strategies on the Eastern Scotian Shelf with Ecosim <i>Alida Bundy and Sylvie Guénette</i> .....	112
The Use of Ecosystem Models to Investigate Multispecies Management Strategies for Capture Fisheries: Report on Southern Benguela Simulations <i>Lynne Shannon</i> .....	118
Impact of Harvesting Strategies on Fisheries and Community Structure on the Continental Shelf of the Campeche Sound, Southern Gulf of Mexico <i>Francisco Arreguín-Sánchez</i> .....	127
Evaluating Harvesting Strategies for Fisheries of the Ecosystem of the Central Gulf of California <i>Francisco Arreguín-Sánchez and Luis E. Calderón-Aguilera</i> .....	135
Testing Responses of a Tropical Shelf Ecosystem to Fisheries Management Strategies: a Small-scale Fishery from the Colombian Caribbean Sea <i>Luis Orlando Duarte and Camilo B. García</i> .....	142
Exploratory analysis of possible management strategies in Lake Victoria fisheries (Kenyan sector) using the recent Ecosim software <i>Jacques Moreau and Maria Concepcion Villanueva</i> .....	150
<b>Participants in the Workshop</b> .....	155



*This report is co-published as an FAO Fisheries Report*



*A Research Report from  
The UBC Fisheries Centre and the Food and Agriculture Organisation of the United Nations*

*156 pages © Fisheries Centre, University of British Columbia, 2002*

# Director's Foreword

## Ecosim in the Land of Cockayne

There is a famous Breughal engraving, 'Big Fish Eat Little Fish', that illustrates a marine food web by showing how the stomach of each size of fish contains fish of the smaller size class below. I use it to dramatise trophic relationships and, many years ago, it made a neat cover for my textbook (Pitcher and Hart 1982). One student later said that the book cover taught him all he knew. Another Breughal painting is reproduced opposite in hopes it will be equally instructive.

Like the Breughal engraving, Ecopath models take all trophic relationships within an aquatic ecosystem into account, and the approach will be familiar to many readers of Fisheries Centre Research Reports, being the subject of 5 previous issues from 1996 (see below). Ecopath, the dynamic version of Ecopath (Walters *et al.* 1997, 2000) has recently been endowed with routines that not only simulate the consequences of changes in fisheries for all elements in the ecosystem, but can also search for fishing rates that will maximize ecological, social or economic goals. The first report of this important advance made by Carl Walters is presented here.

This new facility has interested FAO because it could lead to a way of managing multispecies fisheries that takes into consideration all elements of the ecosystem, not just those that are subjected to fishing. Hence, the Fisheries Centre and FAO decided to hold a workshop to explore the potential of the new software, and the papers in this report are the result.

Back to that Breughal. The 'Land of Cockayne' is a derisive medieval comment on those who imagine themselves in a paradise where food and luxuries are so easily obtainable that life is comprised of little more than a happy indolence. Or boast that they are in such a place. As Breughal's painting shows (above), Cockayne is evidently such a fool's paradise. The term 'Cockayne' probably derives from 'cake' (OED), and there are similar terms in medieval French. It gave rise to 'Cockneys', inhabitants of London noted for boasting of the miraculous nature of their city, and a similar idea



The Land of Cockayne, by Pieter Breughal the Elder, 1567. As well as illustrating a Fool's Paradise (note the egg on legs and the walking roast pig), the painting also shows how some of the workshop participants felt after a week of simulations.

*Oil on panel, 52 x 78 cm, Alte Pinakothek, Munich.*

also became the 'Big Rock Candy Mountain' of US hobo lore.

What's the moral here? Well - it is all too easy to be seduced by these elegant simulations. The 'Land of Cockayne' is intended to provide a plangent warning that we should continually check simulation results with the real world. And not be tempted to boast that Ecosim optima place us in a far better world. It is a reality check.

The Fisheries Centre Research Reports series publishes results of research work carried out, or workshops held, at the UBC Fisheries Centre. The series focusses on multidisciplinary problems in fisheries management, and aims to provide a synoptic overview of the foundations, themes and prospects of current research.

Fisheries Centre Research Reports are distributed to appropriate workshop participants or project partners, and are recorded in the Aquatic Sciences and Fisheries Abstracts. A full list appears on the Fisheries Centre's Web site, [www.fisheries.ubc.ca](http://www.fisheries.ubc.ca). Copies are available on request for a modest cost-recovery charge.

**Tony J. Pitcher**

*Professor of Fisheries  
Director, UBC Fisheries Centre*

## Literature cited

- Pitcher, T.J. and P.J.B. Hart (1982) *Fisheries Ecology*. Chapman and Hall, London. 414 pp
- Walters, C., Christensen, V., and Pauly, D. (1997) Structuring dynamic models of exploited ecosystems from trophic mass-balance assessments. *Reviews in Fish Biology and Fisheries* 7(2): 139-172.
- Walters, C., Pauly, D., Christensen, V., and Kitchell, J. F. (2000) Representing density dependent consequences of life history strategies in aquatic ecosystems: EcoSim II. *Ecosystems* 3(1): 70-83.
- Mass-Balance Models of North-eastern Pacific Ecosystems. *Fisheries Centre Research Reports 1996, Vol.4 (1)*, 131 pp.
- Use of Ecopath with Ecosim to Evaluate Strategies for Sustainable Exploitation of Multi-Species Resources. *Fisheries Centre Research Reports 1998, Vol.6 (2)*, 49 pp
- A Trophic Mass-Balance Model of Alaska's Prince William Sound Ecosystem for the Post-Spill Period 1994-1996. *Fisheries Centre Research Reports 1999, Vol.6 (4)*, 143 pp
- Ecosystem Change and the Decline of Marine Mammals in the Eastern Bering Sea. *Fisheries Centre Research Reports 1999, Vol.7 (1)*, 106 pp.
- A Trophic Mass-Balance Model of Alaska's Prince William Sound Ecosystem for the Post-Spill Period 1994-1996, 2nd Edition. *Fisheries Centre Research Reports 1999, Vol.7 (4)*, 137 pp.
- 

## Executive Summary

This report comprises the edited proceedings of workshop held at the Fisheries Centre, University of British Columbia in July 2000, jointly sponsored by FAO, Rome and the government of Japan.

This is the first published account of new Ecosim policy search software that aims to find fishing rates that maximize objective functions for economic, ecological, employment or mixed goals. Two papers set out the numerical basis for the software and the procedure that was adopted for the workshop case studies.

The report contains 18 case study papers exploring the use of the ecosim policy software. Papers examine fisheries and their ecosystems in the Strait of Georgia (BC), the Bali Strait (Indonesia), the North Sea, The Faroe Islands, Hong Kong, Lake Malawi, Newfoundland, Port Philip Bay (Tasmania), Prince William Sound (Alaska), the San Matias Gulf (Argentina), the Scotian Shelf (Canada), Southern Benguela (South Africa), Campeche Sound (Mexico), Gulf of California (Mexico), the Caribbean (Columbia).

---

## **The Use of Ecosystem Models to Investigate Ecosystem-based Management Strategies for Capture Fisheries: Introduction**

**Kevern L. Cochrane**  
*FAO, Rome*

### **The Rationale: Providing Scientific Information for Management**

In recent years those involved in the utilisation and management of aquatic resources have come to realise that the single-species or -resource approach still prevailing in the vast majority of fisheries in the world is incomplete and inadequate. Faced with mounting evidence of failures in our on-going attempts to use living aquatic resources in a sustainable and responsible way, we have been forced to re-examine the science, the management and the operations applied in fisheries, and all three have been found to be lacking.

One of the most fundamental deficiencies is now widely considered to be the tendency to focus on fishery resources as essentially independent stocks, driven entirely by their inherent population dynamics, as has been the practice during the dramatic expansion in fishing power and catches that characterised fisheries in the 20<sup>th</sup> Century. In response to this realisation, global attention within fisheries is turning towards recognising that biological populations and communities function within and are ultimately regulated by the ecosystems in which they occur. The challenge now is to translate this intellectual acceptance of the need to manage fisheries as integral parts of the ecosystem, into an effective methodology that allows us to make optimal use of our diverse aquatic ecosystems in a responsible and sustainable way.

The principles of ecosystem-based management of fisheries incorporate and extend the conventional principles for sustainable fisheries development. Instead of focusing on a single-species, ecosystem-based fisheries management strives to consider the capacity of the ecosystem as a whole to produce food, revenues, employment and other essential and desirable services for humankind. From that starting point, it is necessary to devise utilisation and management strategies that enable us to optimise that capacity, taking into account variability in the system and uncertainty in our knowledge. Instead of setting only relatively sim-

ple reference points related to single populations, these strategies will also need to refer to limits and targets related to conservation of ecosystem components, structures, processes and interactions. An immediate implication of this is that the complexity of the system we are considering increases and the number of objectives and the conflicts between those objectives increases substantially. This expansion in uncertainty and complexity is not, however, a consequence of adopting ecosystem-based management, it is the result of recognising and attempting to consider the full complexity and uncertainty that have always been there, but that we have previously ignored.

Fishery scientists, managers and interest groups are generally aware of the need to consider this full range of complexity, but there is still prevalent ignorance as to how to implement an effective ecosystem-based management system in practice, and the practical problems raised by this recognition are considerable. Uncertainties and conflicting objectives have severely hindered successful application of efforts to implement single-species management and will be even harder to deal with as ecosystem interactions are recognised and incorporated.

Both the need for and difficulty of ecosystem-based fisheries management were recognised by the 95 States which met in Kyoto, Japan, from 4 to 9 December 1995 on the occasion of the International Conference on the Sustainable Contribution of Fisheries to Food Security. They formulated the Kyoto Declaration which proposed, amongst other important principles, that States should base their fisheries 'policies, strategies and resource management and utilization for sustainable development of the fisheries sector on the following: (i) maintenance of ecological systems; (ii) use of the best scientific evidence available; (iii) improvement in economic and social well-being; and (iv) inter- and intra-generational equity'.

Subsequent to the Kyoto Conference, the Government of Japan provided financial support to FAO for a programme to assist countries in implementing the Kyoto Declaration. One of the projects undertaken under this programme was entitled "Multispecies Fisheries Management" and aimed to investigate methods of providing scientific advice for improved multispecies and ecosystem-based fisheries management. Under this project, a workshop was held at the Fisheries Centre, UBC, in March 1998 to consider the "Use of Ecopath with Ecosim to Evaluate Strategies for Sustainable Exploitation of Multispecies Re-



sources”<sup>1</sup>. The workshop did not come up with formal conclusions and recommendations, but there was widespread agreement that Ecopath with Ecosim (EwE), as a well-developed and generic ecosystem-modelling tool, could play a useful role in providing important information to decision-makers on fisheries policy and strategies from an ecosystem perspective, complementary to that available from conventional single-species assessments.

This second workshop, also supported by the Government of Japan, was designed to follow-on from that preliminary meeting and to look in more detail, using specific case studies, at the type of information, including its limitations, which can be expected from our existing ability to assess and forecast at the scale of ecosystems.

### The Objective of the Workshop

A key requirement for effective management is good information upon which good decisions can be based, and it is a key role for science and scientists to provide the best available information on the state of the resources and their likely response, or responses, to any planned fisheries or management action. The workshop was intended primarily to address this task and, particularly, to examine the nature of the information at the scale of the ecosystem which scientists can provide for ecosystem-based fisheries management.

The objective of the workshop was therefore to use quantitative ecosystem models to investigate the impact of different multispecies harvesting strategies on the community structure and fishery yields of different ecosystem types with a view to identifying preferred harvesting strategies.

The starting point of the workshop was the models we have available. The workshop was open to any interested scientist who had been working on ecosystem modelling, and each participant was asked to bring a working ecosystem model of an exploited aquatic ecosystem, including the impact of the fishery or fisheries on exploited stocks. In practice, all the models brought to the workshop were EwE models. The participants were also asked to bring, as far as possible, supplementary information which could be used to assist in evaluating and developing realistic management objectives and strategies for their particular ecosystem. This supplementary information included, for example, estimates of pristine biomass

of the different stocks or a suitable surrogate of such estimates, background information on the social and economic importance of the fishery, and estimates of bycatch, discards and unreported catch.

These models and information were to be used by each participant:

- to consider different sets of objectives for their ecosystem;
- to use the models to identify the management strategies which would come closest to achieving those objectives; and
- to estimate the ecosystem consequences of each management strategy.

In doing so, the participants were also asked to consider the key sources of uncertainty in their models and the possible implications of these for their results and conclusions.

This approach effectively uses the ecosystem models as operating models (e.g. Hilborn and Walters, 1992; Cochrane *et al.*, 1998). Such an application was one of the primary goals of the developers of Ecosim, who suggested it could be used to “conduct fisheries policy analyses that explicitly account for ecosystem trophic interactions” (Walters *et al.* 1997) and routines have been provided in Ecosim to assist the user in such exploration of fisheries strategies or policies. A full description of these routines can be found in the Help System of EwE.

The first of the routines is the ‘open loop’ policy search which estimates the time-series of relative fleet sizes that would maximize a multi-criterion objective function that includes net economic value, social employment value, and ecological stability criteria. The relative fleet sizes are used to calculate the relative fishing mortality rates by each fleet type on the affected stocks. The user, in this case the participant at the workshop, could therefore specify the relative priority of economic value, social employment value and ecosystem stability, where ecosystem stability can be defined in terms of relative abundance of the different biological groups included in the model. These relative priorities represent the management goals. The open loop search then identifies the strategy, in terms of relative fleet sizes, that comes closest to meeting those goals.

Ecosim also includes ‘closed loop’ policy simulations that allow the user to examine the consequences of a given management strategy, taking into account the dynamics and uncertainties of the stock assessment and regulatory processes.

---

<sup>1</sup> Use of Ecopath with Ecosim to Evaluate Strategies for Sustainable Exploitation of Multispecies Resources. *Fisheries Centre Research Reports* 6 (2). Fisheries Centre, University of British Columbia, Vancouver. 49pp.

In order to do this, it includes routines to simulate the dynamics of the assessment process, i.e. collection of data including errors in the estimates of biomass or fishing rate, and for the implementation of the assessment results through limitation of the annual fishing efforts.

### Developing the Strategies at the Workshop

#### Determining Strategies for Base Case Management Objectives

It is possible to use EwE to explore policy options in a variety of ways but it was decided that the routines included in EwE for this purpose, the 'open loop' search and the 'closed loop' simulations, would be the primary tools used at this workshop.

The open loop routine uses a non-linear search procedure to determine the optimum fishing rates over time across the fleet, according to the objective function specified by the user in the open loop input screen (Table 1).

The closed loop routine uses the fishing pattern identified as optimum for a specified management goal using the open loop, and then runs a series of forward projections using that fishing pattern but maintaining the target fishing rates of the different fleets in accordance with the annual observations, with specified errors, on the status of the stock.

This routine enables the user to estimate the actual performance of the selected management strategy (i.e. the optimum fishing pattern over time estimated by the open loop routine) given the observation error inevitably encountered by the fisheries manager striving to maintain the fishing rates specified by the policy in a real fishery.

The information generated by these routines could be used, in combination with other sources of information including the results of single-species assessments and fore-

casts, to inform the manager on the strategy or strategies that would best achieve the agreed objectives.

#### Strategies Considered

As a common starting point, participants were asked to investigate strategies that would achieve five "base case" management objectives, of which three (b – d below) were derived directly from the options available in the open loop routine. The base case strategies were:

- a) current fishing strategy;
- b) maximum economic value;
- c) maximum employment;
- d) maintaining ecosystem structure; and
- e) the "big compromise": giving equal priority to achieving economic; employment and ecosystem structure performance.

The strategies b), c) and d) were considered to be extremes and unlikely to be seriously considered as realistic options in the ecosystems being stud-

**Table 1.** The inputs required to specify a management goal under the open loop routine. The entries shown are hypothetical and given as examples only. With those given under Table 1a), the objective non-linear search procedure would attempt to determine the fishing rate pattern which maintained ecosystem stability in accordance with the targets and Importance scorings given in Table 1c.

Value Component	Value Weight
Net economic value	0.01
Net social (employment) value	0.01
Ecosystem stability	1

a) Determining broad policy priorities

Gear Type	Jobs/Catch
Purse seine	0.02
Bottom trawl	0.03
Long line	0.1

b) Specifying the relative employment value of the different fisheries indicating which fisheries will be favoured under Net social value

Biomass group	B ideal / B base	Importance
Phytoplankton	1	0.01
Sardine	1.5	1
Hake	2	1

c) The target biomass (B ideal / B base) and relative Importance of the different biomass groups to specify what ecosystem structure is preferred under Ecosystem Stability

ied. However, examining the implications of each was considered to be informative and the extreme boundaries they represented could provide useful starting points from which to consider multi-objective strategies, such as the 'big compromise'. When considering objectives and strategies for informing managers, as opposed to the exploratory trials undertaken at the workshop, the open loop routine of EwE could be used to explore a wide range of more subtle compromises between the basic Value Components of economic value, social value and ecological stability (Table 1a).

#### *Procedure for Identifying Strategies*

The following specifications and procedures were agreed upon to ensure reliability and comparability in results of this investigation.

- All strategies would be tested over a 20 year simulation unless the results indicated that the ecosystem had not stabilised over that period, in which case the simulation period would be extended until stability was achieved.
- With any non-linear search procedure, there is a danger that the procedure will converge on a local minimum, not on the global minimum for the given objective function. Participants were therefore advised to undertake at least 5-6 separate estimations using the "start at random F's" option in the routine and to check the value of the objective function after each to ensure that the procedure has reached a global minimum.
- Sensitivity analyses were undertaken to investigate the effect of the vulnerability settings used in the simulations as output from Ecosim is particularly sensitive to these values. These were to include options with vulnerability set at 0.4 and 0.7 throughout, as well as any matrix of settings assumed or estimated for that specific ecosystem.
- A discount rate of 0.04 would be used as the default value in the open loop searches.

The fishing rates per fleet, catches obtained, economic values obtained, biomass of the key biomass groups and value of the objective function, including for each Value Component (i.e. economic value, social value and ecosystem stability), were noted for each open loop estimation.

Testing the performance of the current fishing strategy in each ecosystem (option a) required running the model over the 20 year simulation

with the fishing rates of each fleet maintained at the rates used in the underlying Ecopath model. Maximising the economic value, employment or maintaining ecosystem structure required specifying a weight of 1 for the appropriate Value Component shown in Table 1 a), and low, non-zero values (e.g. 0.01) for the other two. Under the "big compromise" it was found that the objective function used in the search procedure generated a negatively biased weight for ecosystem stability and therefore, instead of using equal weights for each of the three Value Components under this scenario, it was found necessary to give weights of, for example, 1 to each of Economic value and Social value but a higher weight (typically between 5 and 25) to ecosystem stability in order to achieve an objective function that generated the desired compromise.

The problem is well illustrated in, for example, the chapters by Vasconcellos *et al.* (see Figure 3) and Bundy (see Figures 2 and 3). In both cases the authors demonstrate the affects of changing the weighting given to the ecosystem value component relative to the other value components and discuss the difficulties associated with identifying an appropriate ecosystem weighting. In other cases authors selected a single weighting which generated a solution in which an acceptable level of ecosystem stability was achieved, while in other cases authors simply used a weighting of one. In these last cases, there is a high probability that the ecosystem stability criterion was dominated by the economic and social value components and that the estimated strategy would not, in fact, achieve the desired result.

This workshop helped to demonstrate the problems in the optimisation routine and to point to ways of addressing it. At the time of the finalisation of this report, suitable mathematical solutions are being considered and may be included in the EwE software in due course.

#### *Defining 'Ecosystem Stability'*

In addition to the mathematical problem just described, a fundamental philosophical issue also arose at the workshop. In discussions on appropriate values to use for the input screen reflected in Table 1 c), it became apparent that the term "Ecosystem Stability" did not mean the same to all participants and that what was considered to be the desired state for an ecosystem was highly subjective. In a policy that excluded fishing, it may be reasonable to specify the desired state by giving all biomass groups equal weight, and indicating the desired B(ideal) for each group as being the estimated pristine biomass (i.e. prior to

fishing). However, shutting down all the fisheries is only rarely a preferred management option and fishing is an integral part of most ecosystems. Fishing must inevitably result in a reduction in biomass of the groups caught by the fishing gear and is also likely to lead to perturbations in other groups. The pristine option is therefore excluded as a feasible goal and the user (or manager in a real fishery) has to identify a generally-acceptable desired state for the ecosystem and its component parts in the presence of fishing.

Just what that desired state will be will frequently prove to be controversial, as was found at the workshop. Here, opinions ranged from: uniform reduction to the same (as a proportion of pristine) precautionary sustainable level in all biomass groups (the 'ecosystem as the sum of its parts' view); maintaining the key exploited groups at their most productive levels (the sustainable utilization view); to striving to maintain species of particular conservation interest, such as cetaceans and turtles, at the highest levels relative to their pristine biomass (the conservationist view). This matter was not finally resolved at the workshop and reflects an important source of potential conflict as fisheries move towards ecosystem-based management. At the workshop, participants therefore tended to explore their own preferred options when considering ecosystem stability. This freedom of choice will not be a possible option, however, when different user groups are competing for the same resources in an ecosystem!

#### *Testing the Strategy with Observation Error: the closed loop*

Once the optimum management strategy had been identified for a given set of objectives, it was then tested for performance in simulations of 20 years in the presence of observation error using the closed loop routine. Under this, the strategy was run 100 times with randomly generated observation error in the index of abundance of each biomass group used each year by the 'manager' in order to maintain the fishing rates at those specified in the strategy. These indices could be specified as either estimated catch or biomass, or the directly estimated exploitation rate of the previous year arising from, for example, a tagging programme. The closed loop routine therefore allows the user to estimate the affects of observation and implementation error on the performance of the strategy identified by the open loop search.

At the end of each set of Monte Carlo runs, participants were requested to record the value of the

objective function for each of the three Value Components for comparison with the results obtained in the open loop routine, and also to determine the spread of the biomass trajectories for each biomass group.

#### *The Wise Use of Policy Search Routines*

The results of the workshops clearly illustrated the valuable role of the open and closed loop policy search routines in exploring ecosystem-based management strategies. These routines provide efficient and objective means of identifying strategies that will best achieve clearly specified and precise objectives. However, many of the papers also illustrate the absolute need to interpret the results cautiously, taking full account of the uncertainties in both the underlying model and in the optimisation routine itself.

The impact of the weighting factor for the ecosystem value component has already been discussed. Similarly the need to initiate the open loop routine with different starting values of  $F$  to ensure that the optimisation was converging on a global minimum was stressed at the start of the workshop. The importance of doing this is well illustrated in the chapter by Mackinson. In his study he demonstrated that different starting values of  $F$  generated considerably different estimates of the optimal management strategy and he used these results to identify an initialisation option and procedure that achieved consistent results.

The sensitivity of the model behaviour to the assumed values of the vulnerability settings was also stressed at the outset of the workshop and this is clearly illustrated in several of the chapters, including those by Martell and his co-authors, Bucharly *et al.*, Mackinson and Shannon. Shannon, for example, estimated optimal fishing mortalities for the pelagic fleet in the southern Benguela ecosystem that varied by a factor of approximately 6 in order to achieve the 'compromise' strategy, depending on whether the vulnerability factor was set at 0.4 or 0.7 across the ecosystem. Mackinson suggested that there was no clear pattern in the relationship between flow control and the estimated resilience of a species or species group to fishing and he advised caution in interpretation, suggesting that 'once a particular policy has been chosen, the response to changes in the assumptions of flow control should be thoroughly examined'. The implications of this are that the different policies, or strategies, being considered need to be examined in an iterative manner, comparing their performance under a range of sensitivity tests. The final strategy to be selected must be the one that performs best under

the range of feasible parameter values and assumptions, and that is robust to the major uncertainties.

The overall conclusions for anyone considering using the EwE policy search routine to explore possible management strategies seriously is that it is a powerful and sophisticated tool, and therefore, as with all comparable models, one that needs to be used carefully and with common sense, not as a simple recipe book. The user must be conversant with the principles of non-linear optimisation and must follow the practices and guidelines that apply to such statistical tests. Without cautious, thoughtful and active use of the software, the probability of dangerously misleading results and conclusions is far greater than that of obtaining sensible and meaningful information.

## Reporting

The results of the investigations described above are discussed in this Report under the chapters prepared by the participants on the ecosystem they were working with. In some cases, the authors were able to undertake the basic simulations and sensitivity tests described above and to go beyond, considering other, more site-specific, management objectives. In other cases the participants found they did not have the time to go beyond the common base-case simulations. Given these discrepancies in progress, it was not possible at the workshop to complete the final task that had been planned, which was to examine the results of the simulations for the different ecosystems to see whether any common or emergent properties could be identified across ecosystems. However, some authors are continuing their investigations and it is planned to publish these extended investigations as a book, including an overall comparison and synthesis based on those on-going investigations.

## References

- Cochrane, K. L., Butterworth, D. S., De Oliveira, J. A. A., and Roel, B. A. 1998. Management procedures in a fishery based on highly variable stocks and with conflicting objectives: experiences in the South African pelagic fishery. *Reviews in Fish Biology and Fisheries*, 8: 177-214.
- Hilborn, R., and Walters, C. J. 1992. *Quantitative fisheries stock assessment. Choice, dynamics and uncertainty*. Chapman & Hall, New York. 570 pp.
- Walters, C., V. Christensen and D. Pauly 1997. Structuring dynamic models of exploited ecosystems from trophic mass-balance assessments. *Reviews in Fish Biology and Fisheries* 7: 139-172.
-

## Searching for optimum fishing strategies for fishery development, recovery and sustainability

Carl J. Walters, V. Christensen  
and Daniel Pauly

*Fisheries Centre, UBC*

### Abstract

Policy may be defined as an approach towards reaching a broadly defined goal. In fisheries, policies are often implemented via total allowable catches, TACs, that are recalculated annually, and through regulations that affect fleet and deployment. The task of fisheries scientists should be to advise both on policy formulation and on its implementation. However, so far ecosystem-based policy explorations have rarely been conducted. This can, however, now be addressed by the recent development of a policy exploration routine for the Ecopath with Ecosim approach and software. The paper gives an overview of the background for the policy search, and how it has been implemented. A brief overview of a new routine for examining uncertainty in the management process is also included.

---

### On Policy Exploration using Ecopath with Ecosim (EwE)

A central aim of fisheries management is to regulate fishing mortality rates over time so as to achieve economic, social, legal and ecological sustainability objectives. An important dynamic modeling and assessment objective is to provide insight about how high these mortality rates should be, and how they should be varied over time (at least during development or recovery from past overfishing). We cannot expect models to provide very precise estimates of optimum fishing mortality rates, but we should at least be able to define reasonable and prudent ranges for the rates. The impacts of alternative time patterns of fishing mortalities can be explored using two different approaches in Ecosim:

1. Fishing rates can be 'sketched' over time in the Ecosim simulation interface, and simulated results (catches, economic performance indicators, biomass changes) examined for each sketch. This is using Ecosim in a 'gaming' mode, where the aim is to encourage rapid exploration of options.
2. Formal optimization methods can be used to search for time patterns of fishing rates (actually, relative fishing efforts by fishing fleet/gear types), which would maximize particular performance

measures or 'objective functions' for management.

These approaches can be used in combination, e.g. by doing a formal optimization search then 'reshaping' the fishing rate estimates from this search in order to meet other objectives besides those recognized during the search process.

The first of these approaches is what has up to now been the standard simulation form in Ecosim, and does not require further description here, (see Walters *et al.*, 1997; Christensen *et al.*, 2000; Walters *et al.*, 2000). The newly added formal optimization involves three steps:

1. Define blocks of fleet/year groupings to be included in the search procedure;
2. Define objective function weights for the four optimization objectives:
  - (i) net economic value (total landed value of catch minus total operating cost to take this landed value);
  - (ii) employment (a social indicator, assumed proportional to gross landed value of catch for each fleet with a different jobs/landed value ratio for each fleet);
  - (iii) mandated rebuilding of target species (obtained by setting a threshold biomass for the relevant species relative to their biomass in Ecopath);
  - (iv) ecological 'stability' (measured by assign-ing a weighting factor to each group based on their longevity, and optimizing for the weighted sum).
3. Invoke the search procedure by clicking the search button.

When a search has been completed, the resulting 'optimum' fishing rates by year/fleet block are transferred to the Ecosim 'Temporal Simulation', where the optimized fishing rates will have replaced the baseline (or previously sketched) relative efforts by fleet/gear type.

### Methodology

Invoking the search option causes Ecosim to use a nonlinear optimization procedure known as the Davidson-Fletcher-Powell (DFP) method to iteratively improve an objective function by changing relative fishing rates, where each year/fleet block defines one parameter to be varied by the procedure, (e.g., setting four color code blocks means a 4-parameter nonlinear search). DFP runs the Ecosim model repeatedly while varying these parameters.

The parameter variation scheme used by DFP is known as a 'conjugate-gradient' method, which involves testing alternative parameter values so as to locally approximate the objective function as a

quadratic function of the parameter values, and using this approximation to make parameter update steps. It is one of the more efficient algorithms for complex and highly nonlinear optimization problems like the one of finding a best fishing pattern over time for a nonlinear dynamic model.

Nonlinear optimization methods like DFP can be tricky to use, and can give grossly misleading results. In particular the method can 'hang up on a local maximum', and can give extreme answers due to an inappropriate objective function. To check for false converge to local maxima, an option to use random starting F's should be used in addition to forcing additional iterations using the option to redo the analysis based on the current F's. To test for sensitivity of the results to objective function parameters, searches for a variety of values of the objective function weights and parameters should be accessed.

The objective function can be thought of as a 'multi-criterion objective', represented as a weighted sum of four criterion components or indicators: economic, social, legal, and ecological. Assigning alternative weights to these components is a way to see how they conflict or tradeoff with one another in terms of policy choice. For example:

- (a) placing a high weight on the net economic value component (total fishing profits) typically causes the optimization to favor lower fleet sizes and severe simplification of the simulated ecosystem to maximize production of only those species that are most profitable to harvest;
- (b) placing a high weight on the employment (social) indicator typically results in favoring larger fleet sizes, and again often severe ecological simplification in order to maximize production for the fleet that employs the most people.

External pressure, (e.g. in form of legal decisions) may force policy makers to concentrate on preserving or rebuilding the population of a given species in a given area. In Ecosim, this corresponds to setting a threshold biomass (relative to the biomass in Ecopath) and identifying the fleet structure that will ensure this objective. The implication of this policy tends to be case-specific, and to depend on the trophic role of the group whose biomass is to be rebuilt.

The ecosystem criterion component is inspired by the work of E.P. Odum (1971) in terms of 'maturity,' wherein mature ecosystems are dominated by large, long-lived organisms. This is implemented in Ecosim by identifying the fleet structure that

maximizes the biomass of long-lived organisms, as defined by the inverse of their production/biomass ratios. The optimization of ecosystem 'health' optimization often implies phasing out of all fisheries except those targeting species with low weighting factors.

The search procedure results in what control systems analysts call an 'open loop policy', i.e. a prescription for what to do at different future times without reference to what the system actually ends up doing along the way to those times. It would obviously be crazy to just apply an open loop policy blindly over time, each year committing a fishery to fishing rates calculated at some past time from only the data available as of that time.

In practice, actual management needs to be implemented using 'feedback policies' where harvest goals are adjusted over time as new information becomes available and in response to unpredicted ecological changes due to environmental factors. But this need for feedback in application does not mean that open loop policy calculations are useless: rather, we see the open loop calculations as being done regularly over time as new information becomes available, to keep providing a general blueprint (or directional guidance) for where the system can/should be heading. Also, we can often gain valuable insight about the functional form of better feedback policies, (how to relate harvest rates to changes in abundance as these changes occur) by examining how the open loop fishing rates vary with changes in abundance, especially when the open loop calculations are done with Ecosim 'time forcing' to represent possible changes in environmental conditions and productivity in the future. For an example of this approach to design of policies for dealing with decadal-scale variation in ocean productivity for single species management, see Walters and Parma (1996).

### **Maximizing Risk-averse Log Utility for Economic and Existence Values**

One option in the search procedure for optimum fishing patterns is to search for relative fleet sizes that would maximize a utility function of the form  $w_1 \cdot \log(\text{NPV}) + w_2 \cdot S \cdot \log(B) - w_3 \cdot V$ , where the  $w_i$ 's are utility weights chosen by the user, and the utility components NPV,  $S \cdot \log(B)$ , and V are defined as:

- (1) NPV is net present economic value of harvests, calculated as discounted sum over all fleets and times of catches times prices minus costs of fishing, i.e., the discounted total profit from fishing the ecosystem.

- (2)  $S \cdot \log(B)$  is an existence value index for all components of the ecosystem over time. It is calculated as the discounted sum over times and biomass pools of user-entered structure weights times logs of biomasses, scaled to per-time and per-pool by dividing the sum by the number of simulation years and number of living biomass pools.
- (3)  $V$  is a variance measure for the prediction of  $\log(NPV) + S \cdot \log(B)$ . It is assumed to be proportional to how severely the ecosystem is disturbed away from the Ecopath base state, where disturbance is measured at each time in the simulation by the multidimensional distance of the ecosystem biomass state from the Ecopath base state. This term is negative, implying that increased uncertainty about the predictions for more severe disturbances causes a decrease in the mean of  $\log(NPV)$ . The term represents both aversion to management portfolio choices that have high variance in predicted returns, and the observation that the mean of the log of a random variable ( $NPV \cdot PB$ ) is approximately equal to the log of the mean of that variable minus  $\frac{1}{2}$  the variance of the variable. Large  $w_3$ -values can be used to represent both high uncertainty about predictions that involve large deviations of biomass from the Ecopath base state, and strong risk aversion to policy choices that have high uncertainty.

This utility function combines several basic concepts of utility. First, the log scaling of value components represents the notion of “diminishing returns”, that adding some amount to any value measure is less important when the value measure is already large than it is when the value measure is small. Second, the log scaling also represents the notion of “balance”, that no value component should be ignored entirely (unless it is assigned a zero  $w_i$ ); the overall utility measure approaches minus infinity if either net economic performance ( $NPV$ ) or if any biomass component of the ecosystem (any biomass  $B_i$  in  $S \cdot \log(B)$ ) approaches zero. Third, it represents the notion that our predictions about the future of both economic performance and biodiversity (biomasses) become progressively more uncertain for policies that result in more extreme departures from the Ecopath base state about which we presume to have at least some knowledge.

In the terminology of portfolio selection theory in economics, fishing policies result in a portfolio of value components with “expected total returns on investment” equal to  $NPV + S \cdot B$ . But policies that have higher expected total returns are most often also ones that would push the ecosystem into more extreme states, and hence represent portfolio choices with higher variance in total returns.

For example, maximizing the deterministic prediction of  $NPV$  in Ecosim often involves a ‘farm-

ing policy’, in which fishing is deployed so as to severely simplify the ecosystem to maximize production of one or a few species that appear at present to be the most valuable (price, potential total catch). This may even involve deploying some fleets just to remove predators and competitors for the most valued species, just like deploying pesticides and herbicides to remove “pests” in agricultural systems. But simplifying an ecosystem in such ways can make the behavior of the system deeply unpredictable, by creating opportunities for ecological response (population growth) by a variety of species that are rare in the “normal” ecosystem, and hence are not well researched or understood in terms of their potential impacts on valued species should they become abundant.

Simplifying an ecosystem is hence much like investing in high-risk, high-return stock market options; such investments may make you rich, but they may also bankrupt you. Most people are risk-averse as investors, and seek to “spread risk” by investing in “balanced portfolios” with lower expected returns on investment but much lower probabilities of severe loss.

The prediction variance measure  $V$  is not meant to represent all components of variation or uncertainty about future biomasses and fishery values.  $V$  goes to zero for policies that hold or maintain the ecosystem at the Ecopath base state  $B_0$  for every biomass, for all simulation times. It is obviously not correct to suggest that we would expect no variance in future biomasses (and hence in the harvest components of  $NPV$  as well) if such a policy were implemented. Imagine running a very large number of simulations of future biomass changes under such a policy, while varying all possible uncertain quantities such as the Ecopath base biomasses and biomass accumulation rates, productivities, Ecosim vulnerability parameters, environmental forcing inputs representing oceanographic productivity regimes, future demand and price patterns, and changing vulnerabilities to fishing due to biophysical and technological factors. Even for the baseline policy where Ecosim predicts stable (‘flat line trajectory’) expected or mean biomasses over time, these simulations would likely reveal high variances and complex covariance patterns for most biomasses over time, i.e. we would see wide probability distributions of possible future biomass states for the ecosystem. We should not be arrogant enough to suggest that we can describe all the uncertainties well enough to accurately calculate the variances of such distributions. But note that much of that variance in predictions of future biomasses, (and hence variance in the value components) would be due to sources of uncertainty



and variability that are the same no matter what the policy choice, i.e., would cause about the same amount of variance in predictions for any future harvest policy that we might simulate.

When comparing policy choices using an optimization objective function, there is no point in including extra constant terms that do not change with the policy variables, (e.g., a base variance  $V_0$  in predictions that does not change with fishing rate policy and just represents uncertainty about any prediction that Ecosim might make). Hence the  $V$  distance measure is meant to represent only extra variance or uncertainty in predictions for policy scenarios that would likely drive biomasses far from the Ecopath mean state.

Note that Ecosim does not deliberately advocate or promote any particular risk-averse portfolio approach to public investment in ecosystem harvest and existence values. Rather, it provides the logarithmic utility function option so that users who do have highly risk-averse attitudes about ecosystem values can identify policy options that would better meet their objectives. Users should always construct a series of policy scenarios with varying utility weights  $w_1$ ,  $w_2$ , and  $w_3$  on the log utility components, to see how placing different emphases on these components would alter the predicted best policy choice.

Use of these functions for policy exploration will generally involve some balance between these objectives. Indeed, identifying the weighting factors to be given to each of these objectives may be the most valuable aspect of this Ecosim routine.

Thus, to assist the user in achieving this, the starting values of the objective functions have each been standardized relative to their base values (from Ecopath), making them roughly comparable. The first two of these measures tend to pull towards increasing fishing effort, while the two others tend to pull towards reducing effort. Care should be taken to consider this balance when giving relative weightings to the objectives. Also note that the optimizations should be performed with a range of weighting factors for each objective function, rather than with single values, which may miss a well-balanced solution (see *Cochrane, this volume*).

### Open-loop Policy Simulations

The fishing policy search interface of EwE described above estimates time series of relative fleet sizes that maximize a multi-criterion objective function that includes net economic value, social employment value, mandated rebuilding,

and ecological stability criteria. In Ecosim, the relative fleet sizes are used to calculate relative fishing mortality rates by each fleet type, assuming the mix of fishing rates over biomass groups remains constant for each fleet type, (i.e. reducing a fleet type by some percentage results in the same percentage decrease in the fishing rates that it causes on all the groups that it catches). The fisheries and ecosystem may be simulated with Ecosim using the solution found in the policy search interface: this is termed an 'open loop' simulation.

Note that when density-dependent catchability effects are included in the simulations, reductions in biomass for a group may result in fishing rate remaining high despite reductions in total effort by any/all fleets that harvest it. Despite this caveat, the basic philosophy in the fishing policy search interface is that future management will be based on control of relative fishing efforts by fleet type, rather than on multispecies quota systems. It is in any case not yet clear that there is any way to implement multispecies quotas safely, without either using some arbitrary conservative rule like closing the fleet when it reaches the quota for the first (weakest) species taken, or alternatively allowing wasteful discarding of species once their quotas are reached.

If future multispecies management is indeed implemented by regulation of fleet fishing efforts so as to track time-varying fishing mortality rate targets as closely as possible, then a key practical issue is how to monitor changes in gear efficiency (catchability coefficients) so as to set effort limits each year that account for such changes in efficiency. Such monitoring is particularly important for fisheries that can show strong density-dependence in catchability, such that a unit of fishing effort takes a much higher proportion of some stocks (exerts a higher fishing mortality rate per unit of effort) when stock size(s) is/are small.

There are at least two possible ways to monitor the changes in catchability (gear efficiency) discussed above. Both are based on monitoring fishing mortality rates  $F_t$  over time, and using the relationship  $q_t = F_t/f_t$ , where  $q_t$  is fishing rate per unit effort and  $f_t$  is effort.

The first approach is to do traditional biomass stock assessments each year, and to estimate  $F_t$  as  $F_t = C_t/B_t$ , where  $C_t$  is total catch and  $B_t$  is estimated vulnerable stock biomass. The second approach is to directly monitor the fishing mortality rate, estimating probabilities of harvest using methods such as annual tagging experiments and within-year estimates of relative decrease in fish

abundance during fishing 'seasons'.

### Closed-loop Policy Simulations

Ecosim allows users to perform 'closed loop policy simulations' to evaluate the monitoring alternatives discussed above. The evaluations produce time series of biomasses, and also the objective function value components used in searches for optimum long-term fishing rate plans. 'Closed loop' simulations model not only the ecological dynamics over time, but also the dynamics of the stock assessment and regulatory process. That is, a closed loop simulation includes 'submodels' for the dynamics of assessment (data gathering, random and systematic errors in biomass and fishing rate estimates) and for the implementation of assessment results through limitation of annual fishing efforts.

As part of this routine the EwE 'closed loop policy simulation' model, allows specification of:

1. how many closed loop stochastic simulation trials to do;
2. the type of annual assessment to be used (F=C/B versus F directly from tags);
3. the accuracy of the annual assessment procedures (coefficient of variation of annual biomass or F estimates, by stock); and
4. the value or importance weights for the Fs caused on various species by each fishing fleet.

The value weights are used for each fleet/species combination to calculate a weighted average catchability,  $q_t$ , for each fleet type, recognizing that some species may be more important than others in terms of the effect that they might be allowed to have on effort reduction should  $q$  increase over time. For example, setting a zero gear/species weight tells the closed loop simulation to ignore any increases that might occur in the catchability of that species when calculating changes over time in fishing power for that fleet. Setting a high weight ( $\gg 1$ ) tells the system to watch the species very closely when assessing changes in fishing power or impact for the fleet. Internally, this calculation is done by setting

$$q_{it} = (S_j \cdot w_{ij} \cdot F_{ijt}) / (S_j \cdot w_{ij}) / F_{it}$$

for each fleet  $i$ , where the sum is over species  $j$  and the  $w_{ij}$  represent importance weights for the species-specific fishing rates  $F_{ijt}$  estimated for simulation year  $t$ .

Closed loop policy simulations could obviously include a wide range of complications related to the details of annual stock assessment proce-

dures, survey designs, and methods for direct F estimation. We assume that users will use other assessment modeling tools to examine these details, and so need only enter overall performance information (coefficients of variation in estimates) into the ecosystem-scale analysis.

In concluding, we remark that the simulations tools described here may help to engage fisheries scientists in a discussion of how we are to manage ecosystems, not just fisheries, and what the implications are of the choices made.

### References

- Christensen, V., Walters, C. J., and Pauly, D. 2000. *Ecopath with Ecosim: a User's Guide*, October 2000 Edition. Fisheries Centre, University of British Columbia, Vancouver, Canada and ICLARM, Penang, Malaysia. 130 pp.
- Odum, E. P. 1971. *Fundamentals of Ecology*. W.B. Saunders Co, Philadelphia. 574 pp.
- Walters, C., Christensen, V., and Pauly, D. 1997. Structuring dynamic models of exploited ecosystems from trophic mass-balance assessments. *Reviews in Fish Biology and Fisheries* 7(2): 139-172.
- Walters, C., and Parma, A. M. 1996. Fixed exploitation rate strategies for coping with effects of climate change. *Canadian Journal of Fisheries and Aquatic Sciences* 53(1): 148-158.
- Walters, C., Pauly, D., Christensen, V., and Kitchell, J. F. 2000. Representing density dependent consequences of life history strategies in aquatic ecosystems: EcoSim II. *Ecosystems* 3(1): 70-83.

## Simulating Fisheries Management Strategies in the Strait of Georgia Ecosystem using Ecopath and Ecosim

Steven J. D. Martell, Alasdair I. Beattie,  
Carl J. Walters, Tarun Nayar\* and  
Robyn Briese\*

Fisheries Centre and \*Oceanography Dept, UBC

### Abstract

Historically, the Strait of Georgia supported a wide variety of commercial, sport and native fisheries, many of which are now depleted or declining. Here, we use Ecopath with Ecosim to simulate various management policies and analyze their consequences. We first construct an ecosystem model that represents the dynamics of a simplified Strait of Georgia model and then proceed to ask the question “if we could repeat history, what set of harvest policies, for specific fishing fleets, would best represent an omniscient policy?”. More specifically, if we had perfect information about trophic interactions, primary productivity regimes, and changes in catchability, then what is the ‘best’ approximate policy for optimizing economic, social and ecosystem stability goals? Furthermore, how sensitive are these policies to uncertainties in trophic dynamics?

### Introduction

Historically, the Strait of Georgia (SoG) was a productive ecosystem supporting some of the world’s largest commercial, sports, and First Nations’ fisheries. The Fraser River, the centerpiece of the SoG, is the main source of freshwater for many anadromous residents of the SoG, including salmon, eulachon, and tomcod. The SoG is connected to the Pacific Ocean via the Strait of Juan de Fuca and Haro Straits in the South, and the Johnstone Strait in the North. The SoG is an eclectic mix of oceanographic features such as: a large estuarine environment, strong tidal currents, connections to many fjord environments, and a large fetch that allows for wind mixing. In recent years, many of the once bountiful commercial fisheries have been closed due to depressed stocks, and the sports fishery has been severely restricted. In the last decade, scientists have been searching for explanations for the decline of many stocks, but much of this effort has been focused on explaining variation observed in single species stock assessment programs. The only attempt, thus far, at compiling all of the evidence for changes in the SoG ecosystem is a report entitled “Back to the Future: Reconstructing the Strait of

Georgia Ecosystem” (Pauly *et al.* 1998). We use this report as a foundation for examining the dynamic changes that have occurred in the SoG over the last 50 years.

The SoG ecosystem has been heavily exploited for the last 90 years and development in commercial fisheries has shifted the focus from top predators in the ecosystem to more abundant lower trophic level species (Wallace 1998). This phenomenon is known as ‘fishing down food webs’ (Pauly *et al.* 1998, Pauly *et al.* 2000). Salmon fisheries were by far the most important fishery in the early years of fishing development, and by 1897, British Columbia was canning more than 1 million cases of salmon a year (Lichatowich 1999). Both chinook and coho salmon have been heavily exploited in the SoG by the commercial net and troll fisheries, and by sports fisheries (DFO 1999a, DFO 1999b). With almost all SoG coho stock jeopardised, in 1998 a coast-wide closure for all fisheries was implemented for coho, with the exception of a sports fishery for hatchery fish at the mouth of the Capilano River.

As fishing technologies improved, herring fisheries and ground fish fisheries grew rapidly in the 20<sup>th</sup> century, with precipitous results. By the early 1960s, herring stocks were being harvested at unsustainable rates and the fishery collapsed in 1967 (Stocker 1993). Since this time, however, herring stocks have recovered to near historically high levels (Schweigert *et al.* 1998). Prior to 1970, herring were mainly fished for use in the production of fishmeal, but after the collapse of the fishery a more valuable roe fishery was developed. Groundfish, such as lingcod and several rockfish species, were also heavily exploited back in the 1900s, and with the introduction of trawl fisheries to the SoG in 1943, exploitation rates rose dramatically (Cass *et al.* 1990, Martell 1999). Invertebrate fisheries have also existed in the SoG for the last 100 years, however, up until the 1950s the fisheries were mainly focused on dungeness crabs and manilla clams (an exotic species). Since the 1950s, there have been developments in shrimp fisheries, geoduck clams, sea urchin, sea cucumbers and octopus fisheries (Ketchen 1983).

With the exception of the collapse in the herring fisheries and now coho fisheries, stock assessment reports have attributed observed declines in abundance to factors other than overfishing. In fact, more attention has been spent on trying to explain environmental processes that may have led to a reduction in marine survival rates in salmon, trends in changes of fish production (Beamish and Bouillon 1995), or changes in food availability associated with changes in physical

**Table 1.** Ecopath basic input parameters and estimated parameters (light shading - *italics*) for the Strait of Georgia in 1950. Trophic levels are estimated from the diet matrix information (Table 2) and the vulnerability parameters are used in Ecosim and were estimated through a fitting procedure in Ecosim.

Group	Trophic level	Biomass (t/km <sup>2</sup> )	P/B (/year)	C/B (/year)	Ecotrp. Effic.	Fishery Land.	Vuln.
Transient Orcas	5.4	0.003	0.02	7.4	0	0	0.3
Dolphins (Res. Orca)	4.1	0.04	0.02	7.3	0.555	0	0.3
Seals Sealions	4.4	0.4	0.16	8.1	0.96	0.04	0.3
Halibut	4.1	0.004	0.44	1.7	0.735	0.001	0.3
Lingcod	4.2	5.591	0.39	1.2	0.168	0.273	0.357
Dogfish Shark	3.7	6.5	0.1	2.5	0.033	0	0.3
Ad. Hake	3.4	7.737	0.5	5	0.86	0	0.143
Juv. Hake	3.1	2.321	2.48	9	0.596	0	0.01
Ad. Res. Coho	3.8	0.198	1.3	3.24	0.955	0.12	0.3
Juv. Res. Coho	3.3	0.838	2.4	7.3	0.475	0	0.4435
Ad. Res. Chinook	3.8	0.33	1.4	5.475	0.951	0.296	0.3
Juv. Res. Chinook	3.3	1.231	2.4	7.3	0.651	0	0
Demersal Fishes	3.5	12.6	0.52	2.5	0.994	0	0.3
Sea Birds	3.2	0.02	0.1	91.7	0.949	0	0.3
Small Pelagics	3.2	2.852	2	18	0.95	0	0.3
Eulachon	3.1	2.114	2	18	0.95	0	0.3
Ad. Herring	3.2	16	0.67	6.3	0.917	7.22	0.3
Juv. Herring	3	3.58	1.172	11.06	0.725	0	0.01
Jellyfish	3	15	3	12	0.211	0	0.3
Predatory Inverts	2.7	9.1	1.65	8.8	0.549	0	0.3
Shellfish	2.1	220.5	0.5	5.6	0.776	0	0.3
Grazing Inverts	2.1	400	3.5	23	0.55	0	0.3
Carn. Zooplankton	2.4	12.94	12	40	0.95	0	0.3
Herb. Zooplankton	2	24.68	25	183.3	0.95	0	0.3
Kelp/Sea Grass	1	20.3	4.43	-	0.158	0	-
Phytoplankton	1	65.2	200	-	0.6	0	-
Detritus	1	1	-	-	0.712	0	-

properties (Robinson 1999). At this time, the occurrence of a 'regime' shift, or long term changes in primary productivity in the Pacific Ocean (Beamish *et al.* 1999), is postulated as the major factor leading to abundance declines in the SoG.

An obvious, but often unresolved, issue is the role of trophic interactions in suppressing recruitment or indirectly changing natural mortality rates (generally assumed to be constant). Among fisheries scientists and academia, there is a growing consensus that we can no longer forge ahead and exploit a resource without considering trophic interactions at an ecosystem scale (Walters *et al.* 1997). The majority of data available, however, are usually restricted to species of commercial importance. In the SoG alone for example, there are more than 250 different species of fish, but fisheries statistics are collected for less than 50 species coast wide (vertebrate and invertebrate combined). Moreover, we have even less knowledge about the specific interactions among members in an ecosystem, a problem we are now forced to face.

The objective of this paper is to first construct an ecosystem model that represents the dynamics of a simplified Strait of Georgia model and then proceed to ask the question "if we could repeat his-

tory, what set of harvest policies, for specific fishing fleets, would best represent an omniscient policy?". More specifically, if we had perfect information about trophic interactions, primary productivity regimes, and changes in catchability, then what is the 'best' approximate policy for optimizing economic, social and ecosystem stability goals? Furthermore, how sensitive are these policies to uncertainties in trophic dynamics?

### Strait of Georgia Ecopath Model

This study builds on the model created for the Back to the Future project (Pauly *et al.* 1998). We started with the present day model and made various changes both to better accommodate our assessment, and reflect recent developments in the software. The major change made was to split up Herring, Chinook, Coho and Hake into juvenile and adult groups. In addition, our Ecopath model is parameterized for the 1950's and in most cases, an increase in biomass was required. One of the latest features of Ecosim allows for fitting specific groups to time series data, and to take advantage of this latest feature we explicitly represent coho, chinook, lingcod, herring, and hake as individual groups. The parameters used for the Ecopath model are represented in Table 1, and the corresponding diet matrix information is in Table 2. Except for the groups specified above, we have adopted the parameters from the Back to the Future project (Dalsgaard *et al.* 1998).

Recent evaluation of herring tagging studies has demonstrated that a large fraction of the Strait of Georgia herring population undergoes annual migrations (Hay *et al.* 1999). For this reason we use 39.7% of the adult herrings diet as imported (Table 2). Similarly, eulachon stocks from the Fraser River system also leave the SoG and we assume that 40% of their diet is imported (Doug Hay, Pers. Comm.).



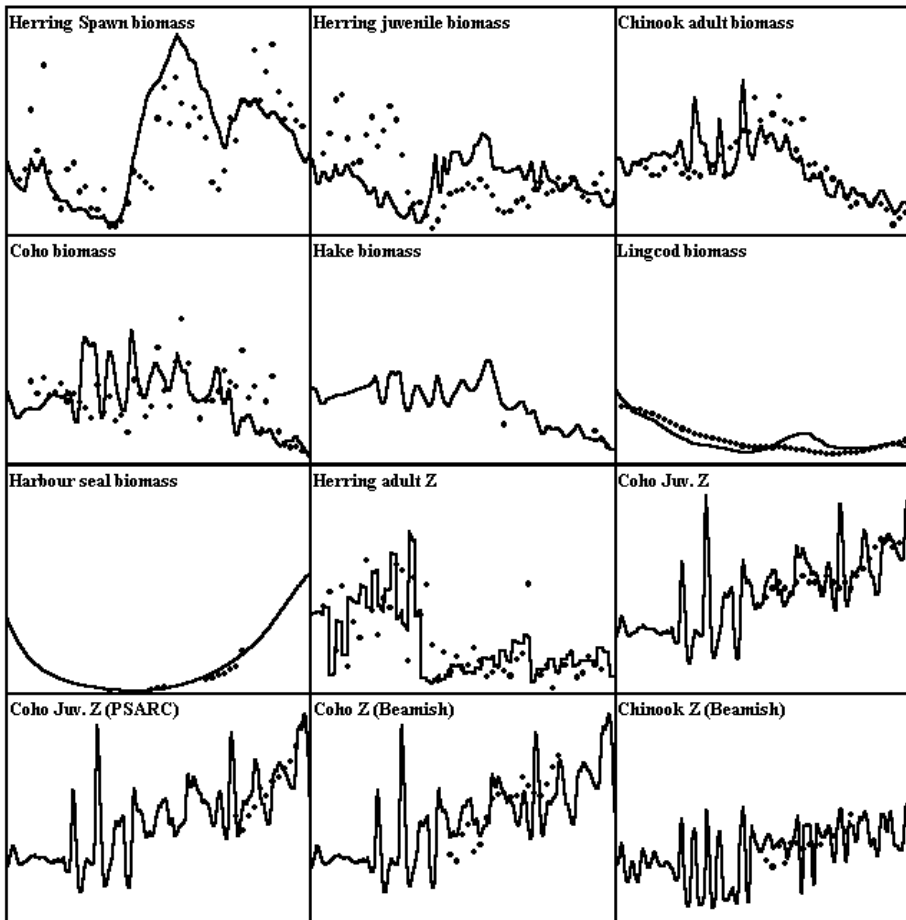

**Figure 1.** Results of fitting Ecosim to time series data for the Strait of Georgia, from 1950 to 1999.

Biomass estimates for herring come from VPA reconstructions (Schweigert *et al.* 1998), and we allow Ecopath to solve for eulachon biomass assuming an EE of 0.95 (see Table 1).

**Fisheries in the Strait of Georgia**

For this analysis, we have defined six different fishing fleets: groundfish, salmon, herring, harbour seal, hake and krill. The ground fish fleet targets lingcod and halibut as well as a small component of the demersal fish group, mostly rockfish and flounder species. The salmon fleet is both commercial and recreational; here we ignore the highly migratory species such as sockeye and pink salmon. The herring fishery is a combination of the commercial gillnet and seine fishery. Up until 1970, the Department of Fisheries and Oceans offered a bounty on harbor seals. There are no published reports on the exploitation rates for harbor seals; however, we have witnessed a substantial increase in abundance since the first population estimate in 1973. We choose a fixed fishing rate of 0.3 from 1950 to 1970 for the harbor seal fishery. The Pacific Hake fishery did not

commence until 1975 in the Strait of Georgia, and the most recent fishery development is the krill (euphausiid) fishery that started in 1997. Krill are members of the carnivorous zooplankton group.

**Fitting Ecosim to Time Series Data**

For Hake, Lingcod, Herring, Coho, Chinook and Harbor Seals, we fit the Ecosim model treating each data series as a relative abundance index. The Ecosim interface allows the user to specify the search routine to adjust vulnerabilities, and/or generate a time series of anomalies. This time series is then applied as a ‘forcing function’ – that is, Ecosim is forced to try to match with these when predicting the next equilibria – to one or more groups. In this assessment, we allow the search routine to generate a time series of primary production anomalies.

such a time series of anomalies can be considered analogous to a recruitment anomaly time series in a single species stock assessment. The result of the fitting procedure is the generation of a primary production regime, and we use this regime in our analysis of optimal fishing policies. For comparison, our analysis incorporates some of the environmental uncertainty that in reality fisheries managers are faced with.

Fitting the salmon data required an additional forcing input on the salmon egg production to emulate the hatchery release programs that started in 1970. This function tripled juvenile salmon production by the early 1980s, and leveled off from 1980 to present day. The present analysis does not investigate how hatchery inputs from the Puget Sound area may have influenced overall survival rates for juvenile salmon. Nevertheless, the increase juvenile salmon production from hatchery inputs leads to a predicted decline in juvenile survival rates for both species of salmon (Figure 1). Prior to 1970, much of the herring dynamics is driven by high exploitation rates

during the days of the reduction fishery. Following the closure of the fishery, herring populations in the SoG grew rapidly. By 1950, lingcod was probably already over-fished, and their continued decline up until 1990 can be attributed to the remaining handline vessels and sports fisheries that operate in the SoG. In 1990 the commercial lingcod fishery was closed, and size and bag limits were imposed on the sports fishery. It is possible that the rapidly growing seal population is, in part, responsible for the failure of lingcod to recover.

### Searching for Optimal Fishing Policies

In the EwE software, we used the fishing policy search routine to examine alternative fishing policies for the six fisheries (Table 3). The harbor seal culling program, which has been abandoned since

**Table 3.** Social employment weights by fishery type.

Fishery sector	Jobs/catch
Ground fish fisheries	2
Salmon fisheries	20
Herring fisheries	10
Seal-culling	1
Hake fisheries	5
Euphausiid fisheries	5

1970, was left in place as an option for predator control programs in the future. Where applicable, sports fisheries (mostly salmon and rockfish) were included into fishing rates calculated for commercial fisheries. The fishing policy optimization routine uses a Fletcher-Powell non-linear search routine to search for optimal fishing rates for each fishery, while maximizing an objective function that incorporates economics, social and ecosystem stability. Each component in the objective function is arbitrarily weighted for importance. For the economic objective we used a 4% discount rate. The social employment weights for each fisher are shown in Table 3. To assign values to each component in the ecosystem, we use 1/PB ratio as the weight (now the default setting in Ecosim) for the ecosystem stability criterion.

We examine five different fishing policies. First we maximize the objective function for economics, social, ecological stability, and ‘the big trade-off’ – all three weighted equally. Finally we compare the results of these four scenarios to the ‘status quo’ situation. Status quo refers to the fishing rates defined in the 1950 Ecopath base model. In our assessment of optimal fishing policies, we evaluate economic, social and ecosystem stability objective functions in terms of percent of the status quo (or baseline fishing rates used in Ecopath).

### Results of Optimal Fishing Policy Search

The objective function values, expressed as percentages of the status quo values, achieved from the optimal fishing search routine are summarized in Figure 2.

Maximizing economic value led to a growth in all fisheries, except the herring fishery that was reduced by 40% (note that this is the most valuable single species west coast fishery). This analysis, however, assumes equal value for all species landed; therefore, the search routine is simply maximizing the total catch of all species. Furthermore, during the 1950’s fishing mortality rates on herring were relatively high ( $F \sim 0.41$ ), and are not sustainable at this rate. When maximizing both social and economic objective functions independently, there was a decrease in ecosystem stability. In contrast, when maximizing ecosystem stability there is a decline in economic and social values.

Maximizing ecosystem stability leads to a large increase in the groups that have slow turnover

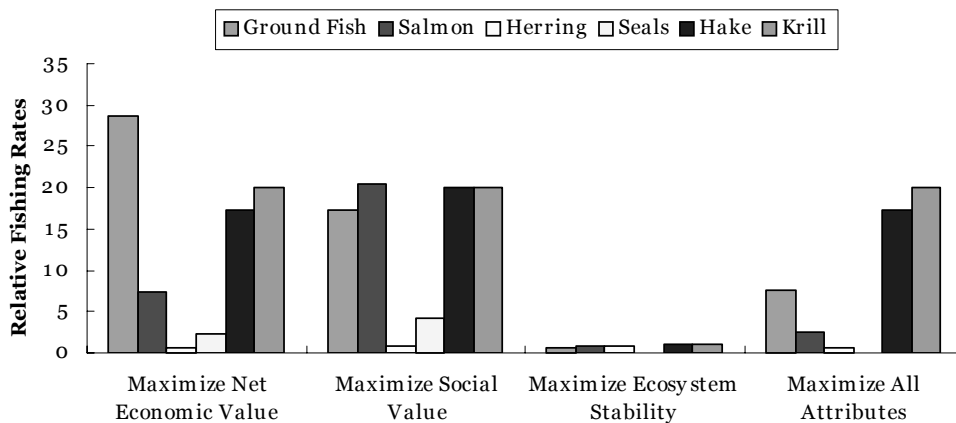

**Figure 2.** Open loop results of the Fishing Policy Optimization routine in Ecosim from 1950 to 2000 with environmental variability incorporated. Objective function values are reported as a percent of the status quo objective function values.

rates (killer whales and birds); however, when we maximize all objective functions the overall value increases over the status quo situation. In fact, there are no differences in ecosystem stability values between the ecosystem stability maximization and maximizing all attributes (Figure 2), yet substantial

improvements in economic and social values are gained from the latter scenario. This difference occurs because when maximizing the ecosystem stability objective, the optimization routine essentially shuts down all fisheries (Figure 3), resulting in economic and social losses, while attaining large gains in the slow turnover species. In contrast, when maximizing all values, economic and social gains are made up through large increases in krill, hake and ground fish fisheries (Figure 3).

### Implementing Optimal Fishing Policies

Implementing the optimal fishing policies above was carried out using a closed loop simulation routine, where uncertainties in stock size estimation and improvements in capture rates due to density dependent catchability and/or improvements in fishing technology are incorporated. In the closed loop simulations we use a coefficient of variation of 50% for biomass estimates, allow catchability to increase at a maximum rate of 10% per year, and use the mean objective function values from 50 model runs. The results of the closed loop simulations are presented in Table 4, where the percentages represent the fraction of the values obtained from the open loop simulations shown in Figure 1. For example, if we were to implement the fishing policy suggested by maximizing all attributes, then we would expect, on average, to achieve 93% of the overall value shown in Figure 1. In other words, due to uncertainty in estimating stock size and changes in catchability, we can expect to lose 7% of the overall value in comparison to having perfect information.

The values obtained in Table 4 are likely unreasonably high. In general we would expect more than 25% of a loss

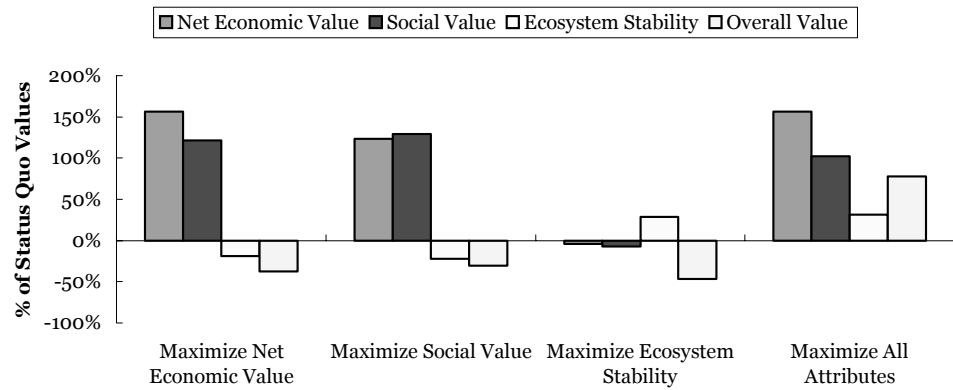

**Figure 3.** Optimized fishing rates for each objective function. Values are relative to the Ecopath base fishing rates.

in anyone of these values due to uncertainty in stock size and changes in catchability. However, in our analysis, the shellfish and carnivorous zooplankton groups dominate the biomass in the model and also have either no long-term fisheries or no fisheries associated with them. These two groups alone, even with relatively small importance weights, dominate the ecosystem stability index. It is unclear, at this moment, as to why the economic objective function values increase over the open loop values.

### Sensitivity of Fishing Policies to Vulnerabilities

We carried out a simple sensitivity analysis to see how sensitive optimized fishing policies are to uncertainties in estimating the vulnerability parameters. In our analysis we used the optimized fishing policy that maximizes all objective functions, then re-ran the model using a range of vulnerabilities from 0.2 to 0.6. Note here that after changing the vulnerabilities we did not re-optimize the fishing fleets because we are interested in how robust the fishing policy is to uncertainty in the vulnerability parameters.

Figure 4 shows the relative values of the open loop objective functions over a range of vulnerabilities. Increasing the vulnerability parameters increases all objective function values. The gen-

**Table 4.** Results of implementing various fishing policies given uncertainty in estimating stock size and changes in catchability. Percentages represent fraction of the values obtained in the open loop simulation (Figure 1).

	Maximize net economic value	Maximize social value	Maximize ecosystem stability	Maximize all attributes
Net economic value	111%	132%	104%	104%
Social value	74%	76%	78%	75%
Ecosystem stability	100%	100%	100%	100%
Overall value	110%	77%	100%	93%



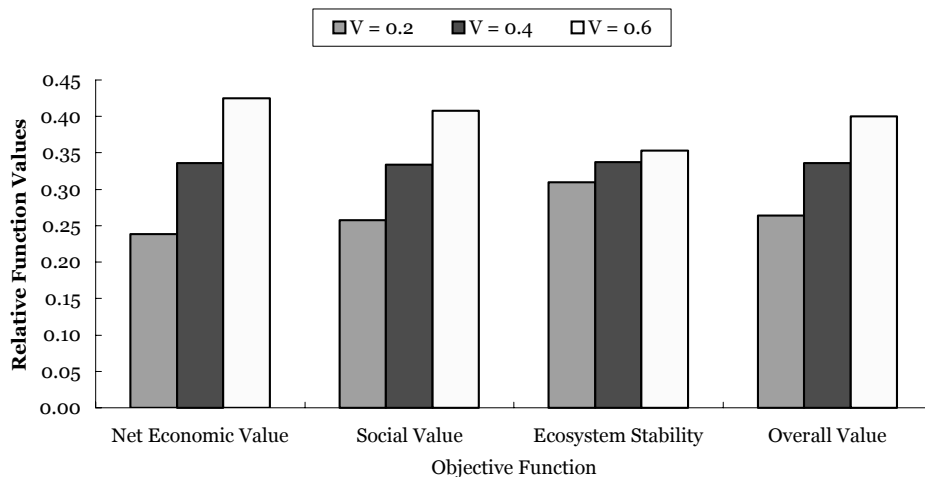

**Figure 4.** Sensitivity of objective function values to the vulnerability parameters in Ecosim. The objective function values have been scaled for comparison.

eral response of increasing vulnerabilities results in decreased productivity and less resilient to over-fishing; therefore from a fishing policy perspective, it is best to hedge by assuming higher vulnerabilities. Using lower vulnerabilities assumes more of a donor-control system, therefore higher trophic level organisms are more sensitive to changes that occur in the bottom of the food chain, which calls for extreme caution in harvesting low to mid-trophic level species.

## Discussion

In our analysis of alternative fisheries management strategies for the Georgia Strait we have incorporated environmental, trophic interactions and anthropogenic effects that we believe best represent the history of the Strait of Georgia ecosystem. In our attempt to recreate the dynamics of the SoG ecosystem, we were able to generate a time series of primary production anomalies that greatly improve the fit to observed data. Although we provide no statistical measure of model fits, the environmental time series pattern generally agrees with other environmental correlates that suggest a regime shift (Beamish *et al.* 1999). Furthermore, fitting Ecosim to relative abundance data in the Strait of Georgia, is one of the first examples of ‘ground-truthing’ Ecosim to real data. In the context of workshop objectives, our analysis differs because we incorporate the effect of environmental variability, and thus our results do not examine before and after type scenarios. Here we evaluate the performance of each fishing policy using the objective function from the open and closed loop routines.

Fishing policies that maximize social or economic values generally increase fishing rates on four of the six fisheries, including the salmon fisheries,

despite having high initial fishing rates in the 1950’s. The salmon fishery is a special case, however, because of large inputs of hatchery fish starting in the 1970’s. In searching for an optimal fishing policy, the search routine foresees the improvements in salmon egg production (this is how we simulated the effects of hatcheries), and increases fishing rates. The hatchery input has also affected juvenile survival rate for salmon. As the

time series data in Figure 1 demonstrate, there has been an increase in juvenile mortality rates about the same time hatcheries came on line. In conjunction, primary production is thought to be declining around this time period (Beamish *et al.* 1997, Beamish *et al.* 1999), ultimately leading to a reduced carrying capacity for juvenile salmon. It is clear in our analysis that both hatchery inputs and a reduction in primary productivity have had a significant impact on salmon populations in the SoG. In general, however, it is of no surprise that most of the fisheries defined here are to increase under the optimal policy. Because of relatively low base fishing rates defined in Ecopath and a downward trend in primary productivity, the optimal response should be to increase fishing pressure and catch the fish before they die of starvation.

Ecosim predictions are highly sensitive to the set of vulnerability parameters, which measure the rate of exchange between behavioral states of vulnerable to invulnerable. High vulnerabilities imply a ‘top-down’ control that often leads to predator-prey cycles, and these groups are very sensitive to over-fishing. As mentioned earlier, a conservative fishing policy will hedge by using vulnerabilities erred on the high side. At this time, Ecosim offers several methods for bounding vulnerability parameters, and fitting Ecosim models to real data looks promising. However, just as in single species stock assessment programs, ‘probing’ experiments (e.g., deliberate over-fishing) are required to provide adequate contrast in the data. Without such contrast, the ability to estimate vulnerability parameters is severely confounded.

It is clear from many failures in single-species stock assessment and management programs that

we can no longer forge ahead blindly, ignoring trophic interactions and environmental influence on ecosystem dynamics. In our analysis of the Strait of Georgia, it is evident that both salmon hatchery production and changes in primary production have had a significant impact on salmon stocks. Seal culling programs were largely ineffective in salmon conservation, and have also threatened other species that we place high values on (e.g. transient, i.e. marine mammal-eating, killer whales). In his keynote address at the 1996 Alaska Sea Grant Fisheries Stock Assessment Models Symposium, Keith Sainsbury called for a new paradigm in resource assessments (Sainsbury 1998), specifically for methods that assimilate large and diverse sets of data. Ecopath with Eco-sim is such a tool.

## References

- Beamish, R. J., C. Mahnken, and C. M. Neville 1997. Hatchery and wild production of Pacific Salmon in relation to large-scale, natural shifts in the productivity of the marine environment. *ICES Journal of Marine Sci.* 54: 1200-1215.
- Beamish, R. J., D. J. Noakes, G. A. McFarlane, L. Klyashtorin, V. V. Ivanov, and V. Kurashov 1999. The regime concept and natural trends in the production of Pacific Salmon. *Can. J. Fish. Aquat. Sci.* 56: 516-526.
- Beamish, R. J., G. A. McFarlane, and R. E. Thomson 1999. Recent declines in the recreational catch of coho salmon (*Oncorhynchus kisutch*) in the Strait of Georgia are related to climate. *Can. J. Fish. Aquat. Sci.* 56: 505-515.
- Cass, A. J., R. J. Beamish, *et al.* (1990). Lingcod (*Opiodon elongatus*). *Can Spec. Pub. Fish. Aquat. Sci.* 40 p.
- DFO 1999a. Fraser River Chinook Salmon. DFO. Science Stock Status Report D6-11 (1999).
- DFO 1999b. Coho Salmon in the Coastal Waters of the Georgia Basin. DFO Science Stock Status Report D6-07 (1999).
- Hay D. E., P. B. McCarter, and K. Daniel 1999. Pacific herring tagging from 1936-1992: A re-evaluation of homing based on additional data. Canadian Stock Assessment Secretariat Research Document 99/176.
- Lichatowich, J. 1999. Salmon without Rivers. Island Press, Washington D.C., 317 pp.
- Martell, S. J. D. 1999. Reconstructing Lingcod Biomass in Georgia Strait and the Effect of Marine Reserves on Lingcod Populations in Howe Sound. M.Sc. Thesis, University of British Columbia. 89p.
- Myers, R. A., K. G. Bowen, and N. J. Barrowman 1999. Maximum reproductive rate of fish at low population sizes. *Can. J. Fish. Aquat. Sci.* 56: 2404-2419.
- Pauly D., Pitcher, T., Priekshot, D., and Hearne, J. (eds) Back to the Future: Reconstructing the Strait of Georgia Ecosystem. Fisheries Centre Research Reports 6(5): 99 pp.
- Pauly, D., V. Christensen, J. Dalsgaard, R. Froese and F. Torres, Jr. 1998. Fishing down marine food webs. *Science* 279: 860-863.
- Pauly, D., V. Christensen, R. Froese, and M. L. Palomares 2000. Fishing Down Aquatic Food Webs. *American Scientist*, 88: 46-51.
- Sainsbury, K. 1998. Living marine resource assessment for the 21<sup>st</sup> Century: What will be needed and how will it be provided? *In Fisheries Stock Assessment Models*, Ed. F. Funk, T. J. Quinn II, J. Heifetz, J. N. Ianelli, J. E. Powers, J. F. Schweigert, P. J. Sullivan, and C.I. Zhang, Alaska Sea Grant College Program Report No. AK-SK-98-01, University of Alaska Fairbanks.
- Schweigert, J. F., C. Fort, and R. Tanasichuk 1998. Stock assessments for British Columbia Herring in 1997 and forecasts for potential catch in 1998. *Can. Tech. Rep. Fish. Aquat. Sci.* 2217: 64 p.
- Stocker, M. 1993. Recent management of the B.C. herring fishery, p. 267-293. *In*. L. S. Parsons and W. H. Lear (Eds.) *Perspectives on Canadian Marine Resource Management*. *Can. Bull. Fish. Aquat. Sci.* 226.
- Wallace, S. S. 1998. Changes in Human Exploitation of Marine Resources in British Columbia (Pre-Contact to Present Day). Pages 58-64 in: Pauly D., Pitcher, T., Priekshot, D., and Hearne J. (eds) *Back to the Future: Reconstructing the Strait of Georgia Ecosystem*. Fisheries Centre Research Reports 6(5): 99 pp.
- Walters, C. J., V. Christensen, and D. Pauly 1997. Structuring dynamic models of exploited ecosystems from trophic mass-balance assessments. *Reviews in Fish Biology and Fisheries*. 7: 139-172.
- Walters, C. J., D. Pauly, V. Christensen, and J. F. Kitchell 2000. Representing density dependent consequences of life history strategies in aquatic ecosystems: Ecosim II. *Ecosystems* 3: 70-83.
- Walters, C. J., D. Pauly, V. Christensen, and J. F. Kitchell 2000. Representing density dependent consequences of life history strategies in aquatic ecosystems: Ecosim II. *Ecosystems* 3: 70-83.

# The Use of Ecosystem-based Modelling to Investigate Multi-species Management Strategies for Capture Fisheries in the Bali Strait, Indonesia

Eny Angraini Buchary<sup>1</sup>, Jackie Alder<sup>2</sup>, Subhat Nurhakim<sup>3</sup> and Tonny Wagey<sup>4</sup>

<sup>1</sup> Fisheries Centre, UBC

<sup>2</sup> Edith Cowan University, Western Australia

<sup>3</sup> Research Institute for Marine Fisheries, Jakarta, Indonesia

<sup>4</sup> Dept. of Earth & Ocean Sciences, UBC

## Abstract

An Ecopath model of the lemuru (*Sardinella lemuru*) fishery located in the Bali Straits (Indonesia) was constructed to test the usefulness of the model in testing a range of management strategies for this dominant fishery using Ecosim simulations. Four management scenarios: maximizing the net economic benefits; maximizing ecosystem stability; maximizing social (employment) values; and a compromise of the above three strategies were used with three different vulnerability values. The results from the model provided were plausible within the information provided for the exploitation levels recorded for the fishery. The policy advice for the four management strategies was to reduce the catch which coincides with the conclusions of recent single species investigations. The model proved to have a useful role in managing the lemuru fishery, the policy advice, however, could be improved substantially by incorporating the SOI (Southern Oscillation Index), improving the information on prices and landings, and expanding the ecological and biological knowledge base for primary producers, non-commercial species as well as for marine mammals, invertebrates and seabirds.

## Introduction

The Bali Strait is located between the islands of Java and Bali (Figure 1) with the Bali Sea to the north and the Indian Ocean to the south. It is funnel shaped with the southern opening approximately 55 km wide and the northern opening 2.5 km wide. The Strait is bounded on the west by a narrow shelf (adjacent to East Java province) and a wider shelf on the east (adjacent to Bali province). The Strait is deepest in the southern end. Depths range between 50 m in the north and 1,400 m in the south. Indian Ocean water tends to dominate the water mass in the Bali Strait. During the southeast monsoon upwelling occurs with the peak effect in July and August (FAO/NGCP 1999; Merta *et al.*, 2000).

The lemuru (*Sardinella lemuru*) fishery is the dominant fishery in the Strait. Other small pelagic species such as sardine species (*Sardinella* spp.), round scads (*Decapterus* spp.), bonito (*Sarda* sp.), mackerel (*Rastrelliger* spp.) and tunas (*Auxis* spp., *Euthynnus affinis*) are either caught as by-catch or targeted. The dominant gear used is the purse seine, some fishers use Danish seine and there is a small line fishery for demersal fish. A new line fishery targeting hairtail (*Trichiurus* spp.) is developing in the Bali Strait.

Commercial fishing in the Bali Strait is restricted to fishers based in Muncar (East Java) and Kedonganan (Bali). Fishing generally occurs in the northwest monsoon (September to January). The lack of a harbour in Kedonganan and rough seas from late November to March also prevents purse-seiners from operating during these times.

Like most small pelagic fisheries, the Lemuru fishery is highly variable, which is reflected by its landing between 1995 and 1998 (Table 1). The stock assessment of the Lemuru fishery is considered to be highly variable due to the schooling behaviour of the fish, the impact of ENSO (El Niño and Southern Oscillation) and the upwelling that occurs in the southeast monsoon. Therefore, validity of the single species methods used in previous assessments of the Lemuru fishery, which indicated that the fishery may be overfished, is questioned (FAO/NGCP 1999). Nevertheless, concern was raised over the current effort levels that may drive the fishery to extinction by overfishing and reduction of spawning biomass to very low levels should a more severe environmental condition occur in the Strait (Ghofar *et al.*, 2000).

A multi-species stock assessment of the fisher-

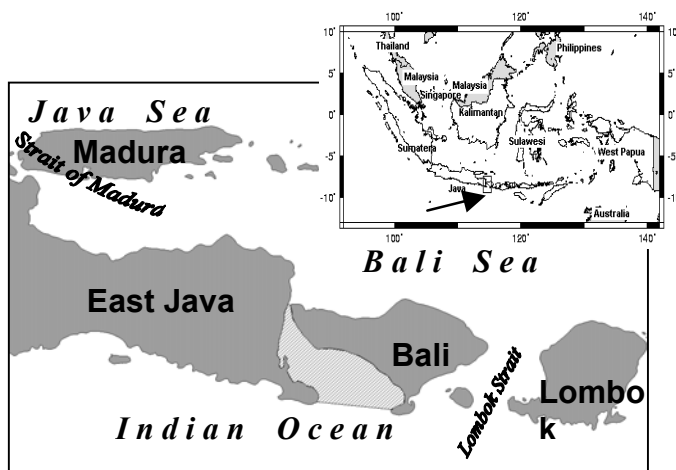

Figure 1. Location of the study area (shaded area).

**Table 1.** Annual landings (tons) of the Bali Strait fisheries, 1995-1998 (Source: DGF Annual Statistics, 1995 to 1998).

Species Landed	1995	1996	1997	1998
Scads	2,796	1,051	460	1,422
Mackerel	303	567	104	596
Eastern Little Tuna	5,963	9,191	1,653	5,004
Lemuru	9,335	9,770	45,994	76,796

ies in the Bali Strait is lacking. There is also limited ecosystem research on the Bali Strait. Previous research mainly focused on the Lemuru as a single-species fishery, with environmental variability given limited attention. Ghofar *et al.* (2000) recently fitted the SOI (Southern Oscillation Index) into the surplus production model of the Lemuru fishery in Bali Strait. Despite the good fit, they suggested the application of models such as ECOPATH, ECOSIM and ECOSPACE that could incorporate such environmental parameters, to be used to assist in the management of this fishery.

This report presents a preliminary multi-species fisheries model of the Bali Strait ecosystem. Model construction was conducted using the latest development of the ECOPATH with ECOSIM ver. 4.0 Beta (July 19<sup>th</sup>, 2000 release) computer program, for the FAO/UBC Fisheries Centre Workshop on the Use of Ecosystem Models to Investigate Multispecies Management Strategies for Capture Fisheries. Although environmental parameters such as the SOI could not be obtained prior to and during the workshop, it is the intention of the authors to refine the model once such parameters are obtained. This report emphasizes the usefulness of ECOPATH with ECOSIM software to explore multi-species management strategies within an ecosystem context. This report therefore focuses on the response of the ecosystem and the fisheries to various management strategies.

## The Bali Strait Ecosystem-based Model

Using a GIS (Geographic Information System) method, the modelled area of the Bali Strait was estimated to be 3,125.98 km<sup>2</sup> (Figure 1). The model developed in this report is based on information from the 1990s.

Model components, in general, were allocated into functional groups based on their similarity in their size, growth, mortality rates and diet (Christensen and Pauly 1992). Important small pelagic fish species in the fisheries, notably Lemuru and Scads, were allocated individually, and the analysis will focus on these fisheries. Other pelagic fish species were divided into 'other small pelagics' and 'medium pelagics'. The designation of 'small' is based on the average or maximum body length of less than 30 cm, while 'medium' is based on the average or maximum body length of between 30 to 50 cm. In the case of Bali Strait, which is dominated by small pelagics, large fish species were not defined as a functional group. Little is known about the demersal fish in the Strait and they were allocated to a single group.

Pelagic fish species were identified from the FAO/NGCP Report (1999). Demersal fish species were adopted from medium demersal fish group of the Java Sea (Buchary 1999). Invertebrate species were identified based on the knowledge of one of the authors, Dr. Subhat Nurhakim (RIMF, July 16, 2000), and from comparing various existing upwelling models (Christensen and Pauly 1993). Consequently, four functional groups were allocated, i.e., zooplankton, macrozoobenthos, benthic infauna, and cephalopods. Seabird species were identified from Whitten *et al.* (1996, Table 7.3, p.383). Whales are known to migrate from Indian Ocean to the Pacific Ocean through passages in Lesser Sunda Islands (IUCN 1991; Jefferson *et al.*, 1993; Rice 1989).

**Table 2.** Input and output (in brackets) parameters of the preliminary Ecopath model of the Bali Strait, Indonesia, in the 1990s. Footnotes for this table are provided as Annex 1 at the end of this paper.

No.	Group	TL	B (t/km <sup>2</sup> )	P/B (year <sup>-1</sup> )	Q/B (year <sup>-1</sup> )	EE	P/Q	Imm. (t/km <sup>2</sup> /yr)	Emm. (t/km <sup>2</sup> /yr)
1	Phytoplankton	1.0	300.00 <sup>i</sup>	30.00 <sup>n</sup>	-	(0.16)	-	0.00	0.00
2	Zooplankton	2.0	(8.79)	38.00 <sup>o</sup>	180.00 <sup>x</sup>	0.50 <sup>aj</sup>	(0.21)	0.00	0.00
3	Macrozoobenthos	2.2	(2.69)	3.20 <sup>p</sup>	13.50 <sup>y</sup>	0.80 <sup>ak</sup>	(0.24)	0.00	0.00
4	Bent. Infauna	2.4	(0.09)	9.00 <sup>q</sup>	30.00 <sup>z</sup>	0.90 <sup>al</sup>	(0.30)	0.00	0.00
5	Cephalopods	3.0	(1.55)	4.71 <sup>r</sup>	16.00 <sup>aa</sup>	0.90 <sup>am</sup>	(0.29)	0.00	0.00
6	Other Sm. Pel. <sup>a</sup>	2.9	(1.59)	(4.50)	18.00 <sup>ab</sup>	0.70 <sup>an</sup>	0.25 <sup>ar</sup>	0.00	0.00
7	Scads <sup>b</sup>	3.1	3.29 <sup>j</sup>	3.50 <sup>s</sup>	11.88 <sup>ac</sup>	0.07 <sup>ac</sup>	(0.30)	0.00	0.00
8	Lemuru <sup>c</sup>	2.8	(9.12)	4.00 <sup>t</sup>	14.00 <sup>ad</sup>	0.95 <sup>ao</sup>	(0.29)	0.00	0.00
9	Med. Pelagics <sup>d</sup>	3.7	(1.84)	(1.91)	9.56 <sup>ae</sup>	0.50 <sup>ap</sup>	0.20 <sup>as</sup>	0.00	0.00
10	Demersal fish <sup>e</sup>	3.5	(0.026)	(1.83)	9.14 <sup>af</sup>	0.80 <sup>aq</sup>	0.20 <sup>as</sup>	0.00	0.00
11	Seabirds <sup>f</sup>	4.0	0.025 <sup>k</sup>	0.05 <sup>u</sup>	67.67 <sup>ag</sup>	(0.09)	(0.001)	0.00	0.00
12	Res. Dolphins <sup>g</sup>	3.9	0.005 <sup>l</sup>	0.045 <sup>v</sup>	12.64 <sup>ah</sup>	(0.53)	(0.0036)	0.00	0.00
13	Trans. Whales <sup>h</sup>	3.8	0.1507 <sup>l</sup>	0.0225 <sup>w</sup>	5.73 <sup>ai</sup>	(0.20)	(0.0039)	0.1507 <sup>at</sup>	0.151265 <sup>at</sup>
14	Detritus	1.0	10.50 <sup>m</sup>	-	-	(0.02)	-	-	-

**Table 3.** Diet composition matrix for all functional groups in the preliminary Bali Strait Ecopath model of the 1990s.

No	Prey/Predator	2 <sup>a</sup>	3 <sup>a</sup>	4 <sup>a</sup>	5 <sup>b</sup>	6 <sup>c</sup>	7 <sup>c</sup>	8 <sup>c</sup>	9 <sup>c</sup>	10 <sup>c</sup>	11 <sup>d</sup>	12 <sup>e</sup>	13 <sup>e</sup>
1	Phytoplankton	0.9	0.3	0.15		0.151	0.233	0.2					
2	Zooplankton		0.2	0.2	0.69	0.776	0.357	0.8	0.2	0.2			0.167
3	Macrozoobenthos		0.01	0.15	0.19				0.075	0.3		0.1	
4	Benthic infauna				0.02	0.007				0.2			
5	Cephalopods				0.02	0.063			0.175	0.13	0.4	0.4	0.533
6	Other small pelagics				0.02	0.003	0.01		0.2	0.05	0.2	0.2	0.077
7	Scads										0.2	0.2	0.057
8	Lemuru				0.01		0.4		0.35	0.051	0.2	0.2	0.167
9	Medium Pelagics									0.048			
10	Demersal fish				0.001						0.02	0.01	
11	Seabirds										0.001		
12	Resident Dolphins										0.001		
13	Transient Whales										0.001		
14	Detritus	0.1	0.49	0.5	0.05								
	Sum	1.00	1.00	1.00	1.00	1.00	1.00		1.00	1.00	1.00	1.00	1.00

<sup>a</sup> Modified from Olivieri *et al.* (1993).

<sup>b</sup> Modified from Buchary (1999).

<sup>c</sup> From FishBase 99 Online (Froese and Pauly 2000). Averaged from each species member to obtain proportional values for each functional group.

<sup>d</sup> Estimated from del Hoyo *et al.* (1992).

<sup>e</sup> Modified from Jefferson *et al.* (1993) and Pauly *et al.* (1998).

Therefore, for the model, marine mammals were split into resident dolphins and transient whales. Species composition of marine mammals for the model were obtained from Tomascik *et al.* (1997, Table 21.23, p.1157).

Little is known about the invertebrate, seabirds and marine mammals groups in the Bali Strait. Therefore, input parameters were obtained mainly from other upwelling systems and other empirical studies, as noted in Table 2. Input parameters for fish groups were mainly sourced from the study area (Table 2). Landing data were obtained from DGF Statistics for the year of 1995 to 1998 (Fauzi, pers. comm.), and input data were estimated as the average of these four years (Table 1). Distribution of landing to fleet categories were based on one of the author’s knowledge of the fisheries, Dr. Subhat Nurhakim (RIFM, July

16, 2000).

Allocations were made as follows: scads (*Decap-terus* spp.) is landed 10% by the handline fishery and 90% by Danish seine fishery, Lemuru (*Sardinella lemuru*) is landed 20% by Danish seine fishery and 80% by purse seine fishery, other small pelagics (represented here by landing of *Rastrel-liger* spp.) and medium pelagics (represented here by landing of *Euthynnus affinis*) are both landed 50% for each Danish seine and purse seine fisheries, respectively.

Diet composition (Table 3) for each fish species was obtained from stomach content analysis col-lated by FishBase 99 Online (Froese and Pauly 2000) and the means were averaged to obtain group diet fractions. As for invertebrates, seabirds and marine mammals, diet compositions were

**Table 4.** Management goals and performance indicators used for searching optimum fishing strategies for the Bali Strait fisheries (TL\* = vulnerabilities adjusted for trophic level).

Management goal	Weights to performance indicators			Vulnerabilities
	Net economic value	Social (em-ployment)	Ecosystem stability	
M1: Maximize net economic value	1.0	0.0001	0.0001	0.2; 0.5; 0.7; TL*
M2: Maximize ecosystem stability	0.0001	0.0001	1.0	0.2; 0.5; 0.7; TL*
M3: Maximize social (employment) value	0.0001	1.0	0.0001	0.2; 0.5; 0.7; TL*
M4: Big Compromise	1.0	1.0	1.0	0.2; 0.5; 0.7; TL*

**Table 5.** Landings (t/km<sup>2</sup>, averaged values of 1995 to 1998 data) of the functional groups caught by three fleet types of the Bali Strait fisheries represented in the model.

Functional Group	Handlines	Danish Seines	Purse Seines	Total
Other small pelagics		0.063	0.063	0.126
Scads	0.046	0.412		0.458
Lemuru		2.43	9.718	12.148
Medium Pelagics		0.872	0.872	1.744
Sum	0.046	3.777	10.653	14.476

**Table 6.** Effort E/S ratio resulting from all management strategies simulated under different trophic control scenarios.

Fishing fleets	Vuln. factor	Base	M1	M2	M3	M4
Purse Seine	v = 0.2	1.52	0.05	0.28	0.02	0.06
	v = 0.5	1.52	0.03	1.52	0.01	0.02
	v = TL*	1.52	0.03	0.28	0.01	0.02
Danish Seine	v = 0.7	1.73	1.73	0.89	0.01	0.02
	v = 0.2	1.11	20.11	1.58	19.17	18.73
	v = 0.5	1.22	11.26	1.22	11.51	11.38
Handline	v = TL*	1.11	11.77	2.79	11.9	11.84
	v = 0.7	0.69	0.69	1.44	8.24	7.94
	v = 0.2	1.11	20.14	0.94	20.14	20.13
	v = 0.5	1.11	20.09	1.11	20.09	20.09
	v = TL*	1.11	20.14	0.92	20.14	20.14
	v = 0.7	20.09	20.09	0.89	20.6	20.6

obtained from existing studies as noted in Table 3. Migration parameters were estimated for transient whales, assuming that they spend approximately two months in the Strait during which they grow at the rate of their production.

The resulting model comprised 14 functional groups (Table 2), which include one primary producers group, four invertebrate groups, five fish groups, two marine mammals groups, one seabirds group, and one detritus group.

*Management Strategies Tested*

Four management strategies were used in the Workshop (Table 4) to search for fishing policy optimization (Christensen *et al.*, 2000). In each of the management strategies different vulnerability values were used, *viz.*, 0.2, 0.5, 0.7. An additional set of vulnerabilities adjusted for the trophic level were used to see how sensitive the model is to strong fluctuations in trophic flow control.

These four management strategies were also compared with the 'Base' which essentially is the current situation where the simulation was run using no particular strategy and that all fishing fleets catch fish using the current fishing rates. Fishing policy search simulations were run for 20 years. Price and cost information were not entered in the model, as the were not available. As noted in Table 1, catch data were obtained only for four pelagic fish functional groups and landed

by three fishing fleets (Table 5).

**Results and Discussion**

*Impact of different management strategies on effort E/S ratio under different trophic control scenarios*

The first management scenario (Maximizing Net Economic Benefit) recommends a substantial decrease in effort for the purse seine fishery (Table 6). However, for the Danish seine and handline fisheries a substantial increase in effort is recommended except at v = 0.7 for the

Danish seine fishery where there is no change in effort (Table 6). The substantial increase in effort recommended by the virtual manager for handline fishery, which targets Scads in this model, depleted Scad biomass after 20 years of simulation (Figure 2). Under this strategy, the system was driven to a situation where trophic interactions caused the Lemuru population to become unstable at v = 0.2 and v = 0.7. Due to the volatility of the Lemuru, piscivorous fish such as scads (who were also heavily fished by increased handlines) and medium pelagic fish (who were caught by Danish seines) became very unstable and even extinct in the case of medium pelagics (except at v = 0.7).

In the absence of the price of landed species and cost of fishing in the model, the recommendation suggested by the virtual manager was to increase relative fishing effort of gear that lands the highest yield. In this case that was the Danish seine fishery (except at v = 0.7), that now primarily catches other small pelagic fish. The interplay of

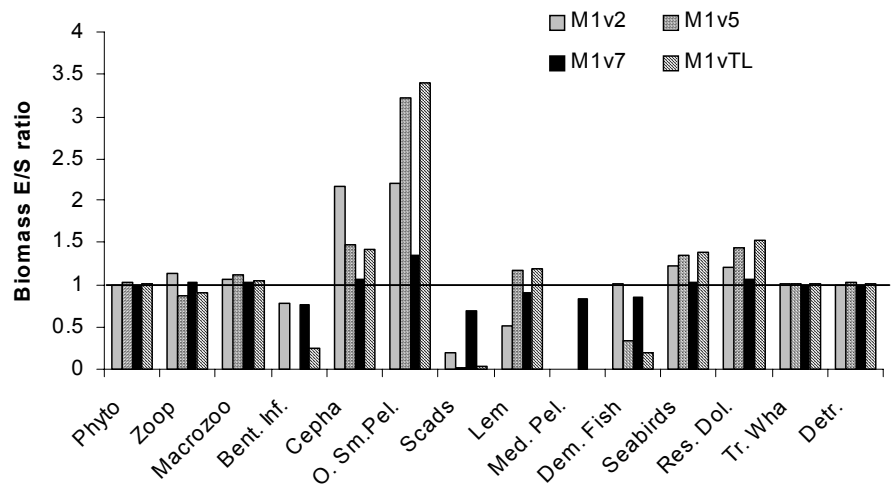

**Figure 2.** Resulting changes in species biomass under management strategy 1 (maximizing net economic benefit), and under different trophic control scenarios.

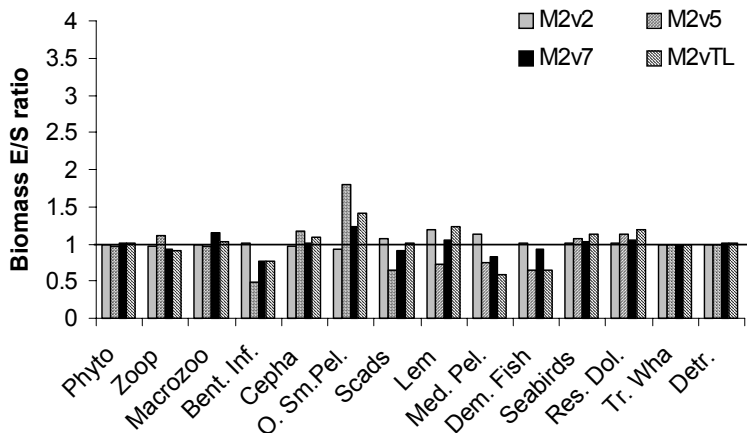

**Figure 3.** Resulting changes in species biomass under management strategy 2 (maximizing ecosystem stability), and under different trophic control scenarios.

trophic dynamics in the system caused other small pelagics' biomass to increase substantially after 20 years (Figure 2). An increased effort in the Danish seine fishery would increase the economic development of the area since the fish caught by Danish seines usually fetch a higher price than the fish landed by purse seines (S. Nurhakim, *pers. obs.*). However, this is accomplished by the virtual closing of the purse seine fishery, and this could have significant social consequences since the catch is processed at a local factory that is a source of local employment (FAO/NGCP 1999). Nevertheless, increasing the Danish seine fishery as recommended by the virtual manager could risk the ecosystem since increasing effort of Danish seines also impacts medium pelagic fish that have a high trophic level, *viz.*, TL = 3.7 (Table 2), and therefore, could reduce the stability of the ecosystem.

In management scenario two, which aims to maximize ecosystem stability, there is a reduction or no change in the recommended effort for the purse seine and an increase or no change in effort for the Danish seine fishery. The recommended effort remains virtually unchanged for the handline fishery except at  $v = 0.7$ , where handline is substantially reduced (Table 6). These recommended efforts across the three fishing gears should provide a reasonable degree of ecosystem stability to the system since there is a more balanced distribution of biomass across the food web (Figure 3). The fishing policy suggested by the virtual manager in management strategy 2 reduces fishing pressure in the system. Therefore, it generated characteristics at the end of the simulation that were similar to those at that at the begin-

ning of the simulation. It is worth noting that this is the only management strategy where  $v = 0.5$  and  $v = 1/TL$  did not generate similar results for effort E/S ratio (Table 6).

Management strategy 3, which aims at maximizing social and employment value, surprisingly generated few differences in recommended effort levels (Figure 4) compared to management scenario one which aims at maximizing net economics value. This may be due to the absence of price and cost input data in the model.

Again a substantial decrease in effort was recommended for the purse seine fishery, and a substantial increase in the handline and Danish seine fisheries. This management strategy focuses on social optimization and since the Danish seine and handline fisheries employ more people per unit weight of landing, then it is logical that effort in these two fisheries increases. In addition, any increase in the Danish seine fishery effort needs to be compensated in the purse seine fishery since the two fisheries overlap in target species and ecosystem impacts.

Despite allocating equal weightings to the performance indicators in management strategy 4 (the big compromise), the virtual manager generated effort recommendations very similar to those recommended for management strategy 3 (maximizing social and employment value). Consequently the impact of this strategy is similar to strategy 3 (Table 6 and Figure 5).

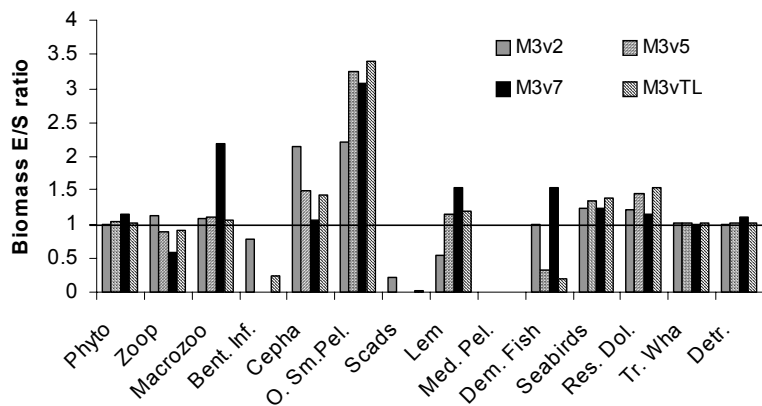

**Figure 4.** Resulting changes in species biomass under management strategy 3 (maximizing social [employment] value), and under different trophic control scenarios.

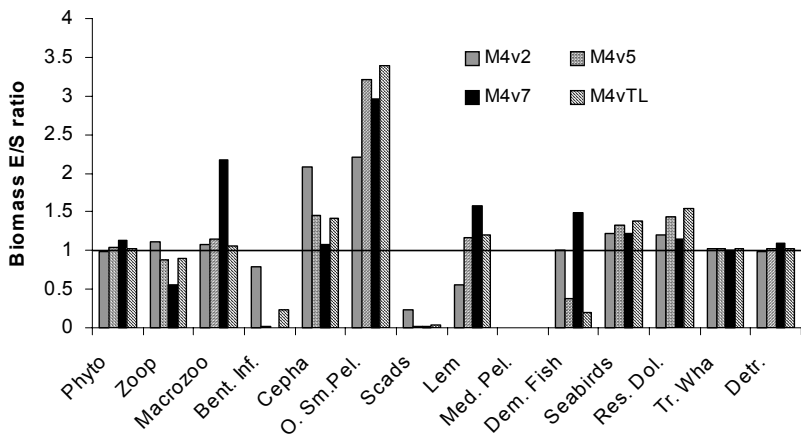

**Figure 5.** Resulting changes in species biomass under management strategy 4 (big compromise), and under different trophic control scenarios.

*Scores of Performance Indicators*

In all trophic control scenarios (except at  $v = 1/TL$  in the closed loop simulation) and under both closed loop and open loop search procedures, the virtual manager suggested M4 strategy (the ‘big compromise’) as the optimal fishing policy since it generated the highest overall values (Tables 7 and 8).

However, when the performance indicators are observed independently of each other - the trend varies according to trophic control scenarios. The overall values also indicate that a management strategy focusing on ecological optimization does not perform well against strategies optimizing for social or economic benefits.

Across the trophic control scenarios and in both closed loop and open loop search procedures, highest scores in ‘net economic values’ were not obtained under M1 strategy (maximizing net economic value) whatsoever. Similarly, the highest scores in ‘ecosystem stability’ were not necessarily obtained under the M2 strategy (maximizing ecosystem stability). However, the highest scores in ‘social (employment) value’ were all achieved under the M3 strategy (maximizing so-

cial/employment value).

The vulnerability parameters had limited impact on the overall performance values. However, when highest scores were taken into account by individual performance indicator, in bottom-up donor control and intermediate control situation, the virtual manager tended to favor the M4 strategy (‘the big compromise’), followed by M3 strategy (maximizing social/employment value). In top-down control and TL-adjusted trophic control, the M3 strategy (maximizing social/employment value) was favoured and followed by the M1 strategy (maximizing

net economic value).

Therefore, in Bali Strait, which is an upwelling ecosystem that may have a “wasp-waist” structure, a search for any management strategy should always consider the variability in trophic flow control to provide a more analytical insight into the system.

**Conclusions**

In summary, for the fisheries where exploitation rates are still low then there is scope for the virtual manager to introduce management regimes and to focus on various sustainability aspects. However, in the purse seine (lemuru) fishery which is highly exploited and has highly variable stocks, the impact of potential management strategies reduced the catches, which is needed to improve ecological, social and economic sustainability of the fishery.

The analysis in this report is not meant to provide realistic fishing policy evaluation for the Bali Strait fisheries, but rather, as an exercise to explore and test the overall responses of the Bali Strait ecosystem model to various multi-species management strategies. A more realistic approach would be to include the SOI (Southern

**Table 8.** Summary of scores for all performance indicators of open loop simulations under all management strategies and different trophic controls.

Performance Indicators	v = 0.2				v = 0.5				v = TL*				v = 0.7			
	M1	M2	M3	M4	M1	M2	M3	M4	M1	M2	M3	M4	M1	M2	M3	M4
Net. Econ. Value	1246.3	512.07	1247.5	1244.9	1444.7	513.16	1448.2	1446.8	1494.0	679.81	1476.0	1496.0	139.06	704.48	1340.99	1337.29
Social. Value	1246.3	512.07	1210.4	1244.9	1444.7	513.16	1404.4	1446.8	1494.0	679.81	1453.0	1495.4	139.06	704.48	2961.12	1337.29
Ecosystem Stability	-57.8	-226.91	-118.09	-54.30	-106.97	-256.1	-132.6	-105.52	-113.93	-199.14	-134.54	-114.08	-73.32	-234.98	-139.28	-118.72
Overall Value	2.17	-0.10	2.93	4.09	2.36	-0.11	3.39	4.59	2.43	-0.09	3.51	4.73	1.91	-0.10	3.13	4.16



**Table 7.** Summary of scores for all performance indicators of closed loop simulations under all management strategies and different trophic controls.

Performance indicators	v = 0.2				v = 0.5				v = TL*				v = 0.7			
	M1	M2	M3	M4	M1	M2	M3	M4	M1	M2	M3	M4	M1	M2	M3	M4
Net. Econ. Value	769.97	366.99	763.66	778.56	791.9	357	789.92	801.48	792.12	457.21	1058.1	800.82	734.64	474.97	769.22	761.89
Social Value	769.97	366.99	7276.17	778.56	791.9	357	7457.6	801.48	792.12	457.21	10288.	800.82	734.64	474.97	7543.8	761.89
Ecosystem Stability	-45.32	-227.54	-99.69	-43.46	-89.52	-254	-110.57	-86.86	-96.76	-200.9	-115.78	-96.99	-85.61	-240.99	-120.41	-100.37
Overall Value	1.3	-0.10	1.76	2.52	1.18	-0.11	1.80	2.43	1.15	-0.09	2.49	2.39	1.08	-0.11	1.82	2.25

Oscillation Index), temporal pattern of primary productivity, economic data, social indicators, better landing data and better biological and ecological information of demersal fish, invertebrates, marine mammals and seabirds.

### Acknowledgements

We would like to thank Dr A. Fauzi for providing us with the landing data of the Bali Strait fisheries and some biological data of the ecosystem, and Dr. R. Watson for estimating the areal extent of the study area and for his help in producing Figure 1. Subhat Nurhakim takes this opportunity to thank FAO for extending the invitation and providing the funding to participate in the Workshop.

### References

- Buchary, E.A. 1999. Evaluating the Effect of the 1980 Trawl Ban in the Java Sea, Indonesia: An Ecosystem-based Approach. Department of Resource Management and Environmental Studies. The University of British Columbia. M.Sc. thesis. 134 p.
- Christensen, V. and D. Pauly 1992. A guide to the ECOPATH II software system (version 2.1). ICLARM Software 6, 72 pp.
- Christensen, V. and D. Pauly 1993. Trophic models of aquatic ecosystems. ICLARM Conf. Proc. 26, 390pp.
- Christensen, V., C.J. Walters and D. Pauly 2000. Ecopath with Ecosim: A User's Guide. Univ. of British Columbia, Fisheries Centre, Vancouver, Canada and ICLARM, Penang, Malaysia. 125pp.
- del Hoyo, J., A. Elliot, J. Sargata and N.J. Collar (eds) 1992. Handbook of the Birds of the World. Vol 1 to Vol 5. International Council for Bird Preservation. Barcelona Lynx Edicions.
- DGF (Directorate General of Fisheries) 1995. Annual Statistics of the Fisheries Landing in Indonesia. Jakarta.
- DGF (Directorate General of Fisheries) 1996. Annual Statistics of the Fisheries Landing in Indonesia. Jakarta.
- DGF (Directorate General of Fisheries) 1997. Annual Statistics of the Fisheries Landing in Indonesia. Jakarta.
- DGF (Directorate General of Fisheries) 1998. Annual Statistics of the Fisheries Landing in Indonesia. Jakarta.
- FAO/NGCP 1999. FISHCODE Management: Report of a Workshop on the Fishery and Management of Bali Sardinella (*Sardinella lemuru*) in Bali Strait. Food and Agriculture Organization of the United Nations, Rome. 30pp. GCP/INT/648/NOR Field Report F-3 (En).
- Froese, R., and D. Pauly 2000. Editors. FishBase. World Wide Web electronic publication. Available at: <http://www.fishbase.org>, 19 September 2000.
- Ghofar, A., C.P. Mathews, I.G.S. Mertha and S. Salim 2000. Incorporating the Southern Oscillation Indices to the Management Model of the Bali Strait Sardinella Fishery. pp. 43-52. In FAO/NGCP (ed.). FISHCODE Management: Papers Presented at the Workshop on the Fishery and Management of Bali Sardinella (*Sardinella lemuru*) in Bali Strait. Food and Agriculture Organization of the United Nations, Rome. 76p. GCP/INT/648/NOR Field Report F-3-Suppl. (En).
- Innes, S., D.M. Lavigne, W.M. Earle and K.M. Kovacs 1987. Feeding rates of seals and whales. *J. Anim. Ecol.* 56: 115-130.
- IUCN (International Union for Conservation of Nature) 1991. Dolphins, Porpoises and Whales of the World. The IUCN Red Data Book. Gland, Switzerland. 429 p.
- Jarre, A., P. Muck, and D. Pauly 1991. Two approaches for modelling fish stock interactions in the Peruvian upwelling ecosystem. *ICES Mar. Sci. Symp.* 193: 178-184.
- Jefferson, T.A., S. Leatherwood, and M.A. Webber 1993. Marine mammals of the world. *FAO Species Identification Guide*. 320 pp.
- Koga, F. 1987. The occurrence properties, biomass and production of zooplankton in Osaka Bay, eastern Seto Inland Sea. *Bulletin of the Seikai National Fisheries Research Institute (Bull. Seikai Reg. Fish. Res. Lab./Seisuiken Kenpo)* 64: 47-66. (In Japanese, with English Abstract).
- Lalli, C.M., and T.R. Parsons 1993. Biological oceanography : an introduction. Oxford: Pergamon Press. 301 pp.
- Merta, I.G.S. 1992. Dinamika Populasi Ikan Lemuru, *Sardinella lemuru* Bleeker 1853 (Pisces: Clupeidae) di Perairan Selat Bali dan Alternatif Pengelolaannya. [Population Dynamics of Lemuru, *Sardinella lemuru* Bleeker 1853 (Pisces: Clupeidae) in Bali Strait Waters and its Management Alternatives]. Ph.D. Dissertation. Graduate Study Programme, Bogor Agricultural University, Bogor. 201p. (In Indonesian).
- Merta, I.G.S., K. Widana, Yunizal and R. Basuki 2000. Status of the Lemuru Fishery in Bali Strait: its Development and Prospects. pp. 1-42. In FAO/NGCP (ed.). FISHCODE Management: Papers Presented

at the Workshop on the Fishery and Management of Bali Sardinella (*Sardinella lemuru*) in Bali Strait. Food and Agriculture Organization of the United Nations. Rome. 76p. GCP/INT/648/NOR Field Report F-3-Suppl. (En).

Nilsson, S.G. and I.N. Nilsson 1976. Number, food and consumption, and fish predation by birds in Lake Mockeln, Southern Sweden. *Ornis. Scand.* 7: 61-70.

Olivieri, R.A., A. Cohen and F.P. Chavez 1993. An ecosystem model of Monterey Bay, California. p. 315-322. *In* V. Christensen and D. Pauly (eds.). Trophic models of aquatic ecosystems. ICLARM Conf. Proc. 26.

Pauly, D., A.W. Trites, E. Capuli and V. Christensen 1998. Diet composition and trophic levels of marine mammals. *ICES Journal of Marine Science* 55: 467-481.

Pauly, D., M.L. Soriano-Bartz and M.L.D. Palomares 1993. Improved construction, parameterization and interpretation of steady-state ecosystem models. p. 1-13. *In* V. Christensen and D. Pauly (eds.). Trophic models of aquatic ecosystems. ICLARM Conf. Proc. 26.

Pauly, D., V. Christensen and V.J. Sambilay 1990. Some features of fish food consumption estimates used by ecosystem modellers. *ICES CM* 1990/G:17. 8 p.

Perrin, W.F. and J.W. Gilpatrick, Jr. 1994. Spinner Dolphin *Stenella longirostris* (Gray, 1828). p. 99-128. *In* S.H. Ridgway and S.R. Harrison (eds.). Handbook of Marine Mammals, vol. 5. The First Book of Dolphins. Academic Press, London.

Reilly, S.B. and J. Barlow 1986. Rates of increase in Dolphin population size. *Fishery Bulletin* 84(3): 527-533.

Rice, D.W. 1989. Sperm Whales, *Physeter macrocephalus* Linnaeus, 1758. p. 177-233. *In* S.H. Ridgway and S.R. Harrison (eds.). Handbook of Marine Mammals, Vol. 4. River Dolphins and the Larger Toothed Whales. Academic Press, London.

Tomasick, T., A.J. Mah, A. Nontji and M.K. Moosa 1997. The Ecology of the Indonesian Seas: Part Two. Periplus Editions. *The Ecology of Indonesia Series*. Volume VIII. pp. 643-1388.

Trites, A. and D. Pauly 1998. Estimates of mean body weights for marine mammals from measurements of maximum body lengths. *Can. J. Zool.* 76(5): 886-896.

Trites, A., V. Christensen and D. Pauly 1997. Competition between fisheries and marine mammals for prey and primary production in the Pacific Oceans. *J. Northw. Atl. Fish. Sci.* 22: 173-187.

Whitten, T., R.E. Soeriaatmadja and S.A. Arief 1996. The Ecology of Java and Bali. Periplus Editions. *The Ecology of Indonesia Series*. Volume II. 969 pp. + photo plates.

Widodo, J. 1995. Population Dynamics of Ikan Layang, Scads (*Decapterus* spp.). Pages 125-136 in M. Potier and S. Nurhakim (eds). Biology, Dynamics, Exploitation of the Small Pelagic Fishes in the Java Sea. Report of the BIODYNEX Seminar, Jakarta, March 1994. PELFISH Project, Jakarta. 281 pp.

## Annex: Footnotes to Table 2

- a Slengseng (*Scomber australis*), Sardines (*Sardinella sirm* and *S. fimbriata*), Mackerels (*Rastrelliger* spp.).
- b *Decapterus macrosoma*, *D. akadsi*, *D. russelli*, *D. muroadsi*, *D. kurroides*, *D. lajang*, *D. maruadsi*, and *D. tabl*.
- c *Sardinella lemuru*
- d Bonito (*Sarda orientalis*), Bullet Tuna (*Auxis thazard*), Eastern Little Tuna (*Euthynnus affinis*), and Hairtails (*Trichiurus lepturus* and *T. auriga*).
- e Assumed to be composed of medium demersal fish.
- f *Fregata minor* (Greater Frigatebird), *F. ariel* (Lesser Frigate), *Sula leucogaster* (Brown Booby) and *Phaeton lepturus* (White-tailed tropic bird).
- g *Tursiops* spp. (Bottlenose Dolphin), *Orcaella brevirostris* (Irrawady Dolphin), and *Globicephala macrorhynchus* (Short-finned Pilot-whale).
- h *Physeter catodon* (Sperm Whale) and *Balaenoptera acutorostrata* (Minke Whale).
- i Guesstimated to be 300. This value was estimated using a combination of other upwelling systems' data, notably of Monterey Bay (Olivieri *et al.* 1993) and Peruvian models (Jarre *et al.*, 1991) and the phytoplankton data from the Bali Strait (Ref. Source from Fauzi) and was analysed using conversion factor of Lalli and Parsons (1993, p. 261).
- j Catch ratio between Scads and Lemuru was 0.1284. The MSY-derived estimated biomass of Lemuru was 25.59 t/km<sup>2</sup> (UNDIP 1992 cited in FAO/NGCP 1999). Hence the biomass of Scads was assumed to be 3.2858 t/km<sup>2</sup>.
- k From the biomass of Booby in Peru60 model (Jarre *et al.*, 1991).
- l Estimated using the weight data from Trites & Pauly (1998), and by using population and area 71 data from Trites *et al.* (1997).
- m Estimated using the empirical formula of Pauly *et al.* (1993) when PP = 300 gC/m<sup>2</sup>/year and E = 50 m.
- n Guesstimated to be 30. Again a combination of guessing and analyzing what information we have on the system.
- o As zooplankton in Bali Strait is mainly comprised of Copepods (Ref. Source from Fauzi), P/B for zooplankton (36.1/year) was adopted from the P/B of Copepods in Osaka Bay (Koga 1987). However, it was then changed to 38/year to improve R/B to 70.
- p From the P/B of Macrobenthos in Monterey Bay (Olivieri *et al.*, 1993).
- q From the P/B of Meiobenthos in Monterey Bay (Olivieri *et al.*, 1993).
- r From the P/B of Micronekton in Monterey Bay (Olivieri *et al.*, 1993).
- s Modified from Z of *Decapterus macrosoma* of eastern Java Sea (Widodo 1995).
- t Merta (1992) estimated that M = 1.00/year and F = 3.38/year for Lemuru; resulting a Z or P/B

- of 4.38/year. This P/B is decreased to 4.00/year to balance the model.
- u From the P/B of Booby in the Peruvian upwelling model. See "Peru50", "Peru60" and "Peru70" (Jarre *et al.*, 1991).
- v Using the assumption of Reilly and Barlow (1986) that the P/B of marine mammals is estimated to be half of the  $r_{max}$  (= rate of increase), the P/B of resident dolphins in the Bali Strait is 0.045/year - using the  $r_{max}$  of tropical Spinner Dolphin (*Stenella longirostris*) in Thailand which is 9% (Perrin and Gilpatrick 1994).
- w Assumed to be half of resident dolphins' P/B, i.e., 0.0225/year.
- x Copepods (*Calanus* and *Acartia*) dominates Bali Strait (Ref. Source from Fauzi). These two species are mesozooplankton. Hence, its Q/B was adopted from the Q/B of mesozooplankton in Monterey Bay (140/year) - also an upwelling system (Olivieri *et al.*, 1993). Increased to 180/year to get higher R/B.
- y Adopted from the Q/B (10.00/year) of Macrobenthos in Monterey Bay (Olivieri *et al.*, 1993). Increased to 13.5/year to get the R/B ratio to increase between 7 to 8.
- z From the Q/B of Meiobenthos in Monterey Bay (Olivieri *et al.* 1993).
- aa From the Q/B of Micronekton in Monterey Bay (Olivieri *et al.*, 1993).
- ab Estimated based on the empirical formula of Pauly *et al.* (1990) using  $W_{\infty}$  data from FishBase 99 Online (Froese and Pauly 2000), resulting a Q/B of 14.06/year. Increased to 18.00/year to improve R/B.
- ac Averaged from the Q/Bs of 8 Scad species (see note b). Estimated based on the empirical formula of Pauly *et al.* (1990) using  $W_{\infty}$  data from FishBase 99 Online (Froese and Pauly 2000).
- ad Estimated based on the empirical formula of Pauly *et al.* (1990) using  $W_{\infty}$  data of *S. lemuru* from FishBase 99 Online (Froese and Pauly 2000), resulting in a Q/B of 11.86/year. Increased to 14.00/year to balance the model.
- ae Averaged from the Q/Bs of 5 medium pelagic fish species (see note d). Estimated based on the empirical formula of Pauly *et al.* (1990) using  $W_{\infty}$  data from FishBase 99 Online (Froese and Pauly 2000).
- af From the Q/B of medium demersal fish in the Java Sea (Buchary 1999).
- ag Averaged from the Q/Bs of 4 seabird species (see note f). Estimated using the empirical formula of Nilsson and Nilsson (1976).
- ah Averaged from the Q/Bs of 3 resident dolphin species (see note g). Estimated using the empirical formula of Innes *et al.* (1987).
- ai Averaged from the Q/Bs of 2 transient whale species (see note h). Estimated using the empirical formula of Innes *et al.* (1987).
- aj Assuming a medium mortality, EE was pre-set to 0.5.
- ak From the EE (0.9) of Macrobenthos in Monterey Bay (Olivieri *et al.*, 1993). Changed from 0.9 to 0.8 to increase R/B.
- al From the EE (0.9) of Meiobenthos in Monterey Bay (Olivieri *et al.*, 1993).
- am From the EE (0.9) of Micronekton in Monterey Bay (Olivieri *et al.*, 1993).
- an Assuming a high mortality, EE was preset to 0.7.
- ao Assuming an over-exploitation condition, EE was preset to 0.95.
- ap Assuming a medium mortality, EE was preset to 0.5.
- aq Assuming a high mortality, EE was preset to 0.8.
- ar Given that P/Q ratio should range from 0.05 to 0.3, with smaller and faster-growing organisms and fish having P/Q close to 0.3, the P/Q for this group was arbitrarily entered as 0.25.
- as Arbitrarily entered as 0.2.
- at Biomass of transient whales was estimated to be 0.1507 t/km<sup>2</sup> in the model (see note l). Assuming that they spend approximately two months in the Strait and grow at their production rate (0.0225/year), they would have their biomass increased by 5.65 x 10<sup>-4</sup> t in two months, resulting an emigration biomass of 0.151265 t/km<sup>2</sup>.
-

## The Eastern Bering Sea

**Kerim Aydin**

*School of Aquatic and Fishery Sciences,  
UW, Seattle*

### Abstract

Ecosim policy maximization routines were used to examine fishing policies for a mid-1980s model of the eastern Bering Sea shelf/slope ecosystem containing 38 functional groups and including catch and bycatch. In addition to yield maximization, the simulations explored “ecological” maximization (using the 1/PB index discussed in the workshop as a criterion) and examined mechanisms for increasing pinniped biomass through selective prey manipulation, especially with respect to the endangered Steller Sea Lion (*Eumetopias jubatus*).

Maximizing to the 1/PB criterion resulted in recommendations for complete ecosystem removal of higher trophic level fish species (specifically Pacific cod; *Gadus macrocephalus*). This removal reduced food competition for slower-lived marine mammals. There is no evidence that such a strategy provides ecological benefits, especially in light of the unpredictability that such a drastic manipulation would entail.

Manipulating pinniped food supply to increase their biomass showed that, without the removal of large fish predators such as arrowtooth flounder (*Atheresthes stomias*), pinniped gains would be modest if fishing policies were set at the scale of the entire shelf and not targeted to local pinniped foraging habitat. Pinniped results were sensitive to the initial apportionment of their diet between juvenile walleye pollock (*Theragra chalcogramma*) and ‘other’ pelagic forage species.

---

### Introduction

One fundamental set of questions that faces fisheries researchers coming to grips with ecosystem-level management is: *ecologically* speaking, is there such a thing as a ‘good’ or ‘bad’ ecosystem? If so, can/should management efforts be directed to ‘improving’ an ecosystem in a meaningful way? Or do such efforts merely support ‘charismatic’ species without coming to grips with the ecological characteristics of a system?

The ability to model many marine ecosystems in the same modeling language afforded by Ecopath allows the comparison of system-level indices of ecosystem structure. Indeed, many of the indices included in Ecopath are built around the ecosystem maturity concept as outlined by Odum (1969).

As a result of this workshop, it was suggested that

an increase in system maturity might occur if fishing strategies were changed so as to maximize biomass, weighting the ‘goodness’ of a biomass increase by the inverse of P/B for a box. In other words, a 10% increase in a slow-lived species would count for more than a 10% increase in a fast-lived species.

This scheme has an intuitive appeal as a first attempt at ecological-based management. The 1/(P/B) weighting scheme (1) can be calculated quickly; (2) seems like an ‘objective’ criterion; (3) its ‘objective’ criteria emphasize what we intuitively might consider to be sensitive species in an ecosystem: long-lived and slow-growing animals. However, before such a scheme can be accepted, it must be challenged: does using P/B as a criteria for increasing species biomass represent an *ecological* improvement in the system, or is it a fancy way of codifying our desire for charismatic megafauna? To test this, the results of fishing optimizations of the Eastern Bering Sea Ecopath model were examined in terms of a few key production and respiration indices of ecosystem maturity.

It should be noted that Odum’s indices may not be the best ecological indicator of ecosystem health—especially in systems where a succession of ecosystem states may be part of the ‘natural order’ of the system. However, Odum’s indices are lowered by most major anthropogenic disturbances, so changes in management policies which lead to increases in ecosystem maturity may be a good thing in the absence of other information or values systems.

### The Model

The Ecopath model used for this set of simulations was based on a model of the Eastern Bering Sea (EBS) presented in Trites *et al.* (1999). The model covers an ocean area of approximately 500,000 sq. km, bordered by St. Lawrence Island on the north, Alaska and the Aleutian Islands on the east and south, and the Bering Sea shelf break on the west.

The EBS is a system in which multiple large-scale changes are known to have taken place, including the near complete removal of baleen whales in the 1950s, the collapse of Pacific herring (*Clupea pallasii*) in the late 1960s, the rapid increase in walleye pollock (*Theragra chalcogramma*) in the late 1970s, the collapse of crab fisheries during the same time period, and the decrease in pinnipeds, especially the currently endangered Steller sea lion (*Eumetopias jubatus*), throughout the 70s, 80s, and 90s. It is not clear which of

these latter changes are due to climate and which to anthropogenic effects.

It is hard to pick a relatively 'stable' time period in which to build a base Ecopath model. Data for the current model is from the time period 1980-85, immediately following years of extremely high pollock recruitment in the modeled area. The model used in the workshop simulations has been modified substantially from the model published in Trites *et al.* (1999). Specifically it includes more detailed catch and discard information for key fish species.

The version of the model used for these simulations is preliminary, and is suitable only as a "test" for the Ecopath techniques covered in this workshop. At press time, projections made by this 1980s model by Ecosim do not fit known 1990s biomass trends, and the model is missing key dynamics for important species, especially with regard to pollock and marine mammals, juvenile fish in diet composition, and the uncertainty in pinniped diets. Please contact K. Aydin for information on current EBS Ecopath models.

The complete model contains 38 boxes, broken down into 10 lower trophic-level groups, (phytoplankton, zooplankton, detrital, infaunal and epifaunal groups), 2 generic forage species groups (forage fish and cephalopods), 4 large crustacean (crab and shrimp) groups, 15 "larger" fish groups (representing the main commercial and bycatch species), 6 marine mammal groups, and 1 bird group.

One group, pollock, was split into juvenile and

**Table 1.** Biomass (t/km<sup>2</sup>), total catch (commercial catch + discards, t/km<sup>2</sup>), and exploitation rate divided by natural mortality rate (F/M<sub>2</sub>+M<sub>0</sub>) for fished or bycatch species in EBS model. G# indicates each of eight distinct fishery "gear types" used in Ecosim simulations. \* species are bycatch, divided among the fisheries.

Species group	G#	Bio.	Catch	F/M
Adult pollock	1	27.45	2.08	0.18
Pacific cod	2	2.42	0.15	0.18
Pacific halibut	3	0.14	.0003	0.06
Greenland turbot	4	0.96	.077	0.25
Arrowtooth flounder	4	0.80	.021	0.07
Small flatfish	5	9.18	.326	0.10
Skates	*	0.29	.019	0.19
Sculpins	*	0.56	.017	0.08
Sablefish	6	0.11	.005	0.13
Rockfish	6	0.09	.003	0.09
Grenadiers	*	0.20	.006	0.08
Eelpouts	*	0.64	.006	0.02
Pacific herring	7	0.78	.055	0.08
Cephalopods	*	3.50	.0007	0.00
King crab	8	0.60	.042	0.13
Tanner crab ( <i>C. bairdi</i> )	8	0.60	.019	0.03
Tanner crab ( <i>C. opilio</i> )	8	1.60	.049	0.03

adult groups: no other juvenile groups were included in the model. However, much of the diet data was integrated over the entire age structure of each fish species, resulting in many cross-connections between fish species from mutual predation on juveniles. Pollock themselves are highly cannibalistic: 70% of predation mortality on juvenile pollock is due to cannibalism by adult pollock in the model.

Calculations of mortality rates indicate that, on the scale of the entire modeled area, the EBS experienced relatively low exploitation rates during the early 1980s, as seen by the ratio of fishing to natural mortality F/M, (Table 1). An F/M of 1.0 would indicate a species fished at the 'traditional' MSY for biomass dynamics models. All of the species groups fished in the EBS had exploitation rates below this level.

For the purposes of the model, the fished species were divided into eight groups for the assignment of 'gears' based partially on management and partially on ecological criteria (Table 1). Bycatch was apportioned to various gear types based on a qualitative examination of bycatch data.

## Methods

Simulations were run using the nonlinear search procedure for optimum fishing strategies included with EwE in the September 2000 version of the model. Thirty years was chosen as the simulation run time, and each of the eight "gears" was set to select a single fishing strategy during the entire simulation period. The nonlinear fishing strategy routine offered four "value" components for determining the ecosystem goal function: economic value, social value, mandated rebuilding, and ecosystem structure.

Within the economic and social components, all retained catch was taken to have the same economic and jobs weighting (default), due to lack of data on commercial catch prices. These scenarios are shown as 'economic' and 'social' in the results.

Two distinct "mandated rebuilding" policies were modeled (1) doubling the biomass of the 3 pinniped groups in the model, representing walrus, multiple seal species, and Steller sea lions; and (2) doubling the biomass of the endangered Steller sea lions only. These scenarios are shown as "pinnipeds" and "Stellers" in the results.

The 'ecosystem structure' component was weighted using the new default criteria of the 'goodness' of a unit increase of biomass of a box

**Table 2.** Change in base fishing rate of eight “gear types” (base rate 1.0) found by nonlinear *Solver* algorithm to maximize economic and social criteria for the EBS model.

Gear	Economic	Social
1. Pollock	1.3	1.6
2. Cod	25.0	21.0
3. Halibut	1.3	1.1
4. Flounder & Turbot	1.6	1.3
5. Small flatfish	25.0	28.0
6. Sable & Rockfish	1.4	1.5
7. Herring	22.0	21.0
8. Crabs	3.3	3.5

relative to others being proportional to 1/(P/B). Scenarios related to ecological structure are shown as ‘Ecol’ in the results.

Each of the four criteria components was maximized for in turn by setting the relative weight of one criterion to 1.0 (NOTE: see *Cochrane this volume*) and all others to 0. Some mixed strategies were also attempted as per the suggestion in the workshop.

The scenarios were run under multiple combinations of Ecosim parameters. Foraging Time Adjustment (FtimeAdjust) was set between 0.0 and 0.5 for all adult groups, and left at 0.5 for juvenile pollock, as suggested by Carl Walters. Flow rate (top-down/bottom up forcing) was set either to 0.3 for all groups, or scaled between 0.2 and 0.9 for trophic levels between 2 and 6, with upper trophic levels being more sensitive to ‘top-down’ effects.

To obtain each solution, the solver routine was run for 100-200 iterations, with this process repeated using different starting F-values, both random and selected. This process was repeated until it was felt that all values to which the routines converged had been found.

**Results**

The results of most of the search results are shown for one set of parameters only: ‘scaled’ flow rates (0.2 for lowest trophic levels to 0.9 for highest trophic levels), with FtimeAdjust set to 0.0 for all boxes except juvenile pollock. This was considered, after workshop discussion, to represent the most ‘realistic’ parameter range in the absence of additional information. With the exception of the ‘ecological’ set of criteria as described below, adjustments to flow and Ftime parameters changed the final optimum fishing rates by 5-20%, but did not change the pattern of results (which fisheries went up and which fisheries went down). The results of the economic and social maximization are shown in Table 2.

Since all species were modeled to have identical economic and social value per-unit biomass, the results are the same for both types of maximization. Fishing on all groups increased: on cod, small flatfish, and herring fisheries this increase was dramatic, removing the species from the system. Increases in fishing of pollock, halibut, flounder & turbot, sablefish & rockfish, and crab were more modest.

On the other hand, the rebuilding of pinnipeds resulted from a reduction in several fisheries: pollock, flounder & turbot, sablefish & rockfish, herring and crab (‘pinniped’ scenario, Table 3). This doubled the biomass of walrus and bearded seals and other seals groups after 30 years, and led to a 1% increase in Steller sea lions. At the same time, cod and small flatfish fisheries were increased, eliminating these species.

When only Steller sea lion rebuilding was mandated using the Trites *et al.* (1999) diet matrix for the species as in the original model, cod fishing was reduced and flounder & turbot fishing increased. The ‘Steller1’ maximization increased Steller biomass by a relatively small 13%, walrus and bearded seals by 51% and other seals by 11% over 30 years.

However, research on sea lion diets being summarized by the U.S. National Marine Mammal Laboratory (*in prep.*) shows that Steller sea lion diet in the EBS is composed mostly of pollock, cod, and cephalopods, and not mostly of the unfished ‘other pelagics’ as in the present version of

**Table 3.** Change in base fishing rate of eight “gear types” (base rate 1.0) found by nonlinear solver algorithm to maximize mandated rebuilding criteria for EBS model. “Pinnipeds” refers to a mandated rebuilding of 3 pinniped boxes representing multiple species, while ‘Steller’ refers to a mandated rebuilding of Steller sea lions only: ‘Steller1’ uses Trites *et al.* (1999) diet compositions for Steller sea lions while ‘Steller2’ uses modified diets consisting of greater proportions of commercial fish.

Gear	Pinnipeds	Steller1	Steller2
1. Pollock	0.3	0.2	0.03
2. Cod	23.4	0.5	0.03
3. Halibut	1.1	1.1	1.0
4. Flounder & Turbot	0.4	18.4	30.0
5. Small flatfish	19.2	12.8	30.0
6. Sable & Rockfish	0.5	1.1	4.7
7. Herring	0.1	0.3	0.5
8. Crabs	0.5	0.9	0.5
<i>Pinniped biomass (year 30/year 0) under fishing strategies above (1.0=year 0 biomass)</i>			
Walrus & Bearded Seals	1.50	1.51	1.55
Seals	1.50	1.11	1.07
Steller sea lions	1.01	1.13	1.73

**Table 4.** Change in base fishing rate of eight gear types (base rate 1.0) found by nonlinear solver algorithm to maximize ecological criteria for EBS model. Two solutions were found by the solver: Ecol1 tended to be found in ‘more sensitive’ parameter configurations.

Gear	Ecol1	Ecol2
1. Pollock	0.1	0.3
2. Cod	19.4	0.7
3. Halibut	0.4	0.7
4. Flounder & Turbot	0.2	0.3
5. Small flatfish	19.3	0.8
6. Sable & Rockfish	0.2	0.4
7. Herring	0.2	0.5
8. Crabs	0.7	0.7

the Trites *et al.* (1999) diet matrix.

When the diet of Stellers was changed to reflect a greater proportion of pollock and cod, a second scenario developed (‘Steller2’ in Table 3).

In this case, the almost complete elimination of fisheries for pollock and cod, along with the increase in flatfish fisheries, led to a 73% increase in Steller biomass after 30 years. Under this change of diet, Steller sea lion increases close to 70% under the ‘all pinnipeds’ maximization as well.

‘Ecological’ rebuilding, weighting increases in biomass proportional to  $1/(P/B)$ , converged to two solutions, depending on starting F-values and Ecosim parameters. The first solution, Ecol1, showed a reduction in all fisheries except cod and flatfish: these latter two species were eliminated from the system (Table 4). On the other hand, the second solution (Ecol2 in Table 4) came about through a reduction in all fisheries.

The Ecol1 solution was found by the solver in ‘sensitive’ ecosystems with high vulnerabilities to top-down predation and/or high FtimeAdjust rates. Ecol2 was found in “less sensitive” ecosystems, with vulnerabilities of 0.3 for all species and FTimeAdjust rates set to 0. Some ‘middle sensitive’ parameter values resulted in convergence on both solutions depending on starting F-values. While both solutions might represent local maxima, Ecol1 had a higher maximization function (= better fit) than Ecol2.

Mixed-strategy results (not shown) showed a mix of the above results, falling towards the components given the heaviest weightings.

## Discussion

Cod and small flatfish were both keystone species in this model: their reduction as predators released a wide variety of biomass of other species

into the system. It is not surprising, then, that their elimination featured heavily in many of the scenarios in Tables 2-4.

Cod, in particular, feed on the same trophic level as many marine mammals while having P/B rates similar to fish: their removal allows for the growth of many longer-lived species because of the the increase of their prey. Eliminating small flatfish in year 1 caused so many changes that the system was substantially ‘out of equilibrium’ in year 30 and even year 50.

It is also not surprising that the recovery of pinnipeds arose through the reduction of the fisheries on key prey species and the elimination of key competitors (Table 3). In particular, if Steller sea lions depend more heavily on fished species than indicated in the Trites *et al.* (1999) model, a reduction in pollock and cod fisheries might substantially increase their biomass. More work on pinniped diet is required to resolve this question—in particular, spatial models should be used to address fisheries’ effects on pinniped popula-

**Table 5.** Year 30/Year 0 biomass of species boxes in the EBS model: (1) after following ‘Ecological’ fishing strategy 1 for 30 years, and (2) after turning off fishing for 30 years (‘Fzero’). Six plankton and detrital groups that changed by less than 1% are not shown.

Species	1 ‘Ecological’	2 ‘Fzero’
Baleen whales	1.06	1.00
Toothed whales	1.20	1.01
Sperm whales	1.00	1.02
Walrus & Bearded seals	1.98	0.98
Seals	2.43	0.97
Steller sea lions	1.00	1.01
Pisc. Birds	1.03	0.44
Adult pollock age 2+	1.07	0.91
Juv. pollock age 0-1	1.03	0.92
Pacific cod	0.00	1.55
Pacific halibut	3.23	0.95
Greenland turbot	2.90	2.02
Arrowtooth flounder	1.30	1.12
Small flatfish	0.00	1.27
Skates	0.00	1.74
Sculpins	0.76	0.78
Sablefish	0.51	1.36
Rockfish	1.66	1.65
Grenadiers	0.86	1.04
Eelpouts	2.71	0.24
Pacific herring	1.30	1.23
Salmon	1.03	1.04
Jellyfish	2.72	0.84
Other pelagic fish	0.97	1.01
Cephalopods	1.01	1.02
Tanner crab ( <i>C. bairdi</i> )	3.48	0.39
Tanner crab ( <i>C. opilio</i> )	5.68	0.24
King crab	1.14	1.16
Shrimp	1.98	0.87
Epifauna	0.70	1.12
Infafauna	0.91	1.04
Benthic amphipods	1.10	0.96

**Table 6.** Primary production (PP), total system biomass (B), respiration (R) and three ecosystem indices: Production/Respiration (P/R), Production/ Biomass (P/B), and Biomass/Energy throughput (B/E), shown for: (1) EBS Ecopath base case; (2) Ecological maximization solution 1 at year 30 (Ecol1); (3) After 30 years with zero fishing (all gears turned off in year 0) ('Fzero'). Percentages show changes in the indices from the Ecopath base case.

	Ecopath	Ecol1	Fzero
PP	2000	1997	1987
B	275	276	278
R	1645	1648	1640
P/R	1.216	1.212 (-0.33%)	1.212 (-0.33%)
P/B	7.27	7.24 (-0.41%)	7.15 (-1.65%)
B/E	0.0755	0.0757 (+0.27%)	0.0767 (+1.59%)

tions.

It is extremely interesting that the “ecological” maximization strategy falls into two categories shown in Table 4: the reduction of all fishing (Ecol2) and the channeling of prey into upper marine mammal populations by the elimination of key fish predators, specifically cod and small flatfish (Ecol1). Can one be said to be better than the other ecologically speaking, outside of the given goal function?

To investigate this, a 30-year run, turning off all fishing in year 0 ('Fzero' scenario) was compared to the results of following the Ecol1 strategy in Table 4 for 30 years. Ecol2 is a less-extreme version of the 'turning off fishing' strategy: all results for the Fzero strategy were true to a lesser extent for Ecol2.

The biomass levels after 30 years (end/start) are shown in Table 5. For Ecol1, the biomass of marine mammals (low P/B ratios) has increased, as have pollock, halibut, turbot, flounder, rockfish, eelpouts, jellyfish, and shrimp, herring, and crabs. At the same time, cod, small flatfish, and skates (cod bycatch) were eliminated and sculpins and sablefish reduced.

On the other hand, with the complete elimination of all fishing, many species increased slightly and only eelpouts decreased dramatically. The increase was spread among many “mid-level” fish species including turbot, skates, rockfish, herring, small flatfish, and cod, while pollock and sculpins, among others, decreased. Marine mammals increased, but changed much less than under Ecol1 (Table 5).

So which is the more mature ecosystem, according to Odum’s criteria? Table 6 shows primary production, total system biomass, and respiration for the base Ecopath, Ecol1 and Fzero scenarios. For more mature ecosystems, P/R and P/B should decrease (as it does for both Ecol1 and Fzero) while B/throughput (B/E) should increase (as it does for both Ecol1 and Fzero). So, both Ecol1 and Fzero are more mature ecosystems than the initial Ecopath equilibrium, according to this selection of indices.

However, the increases in maturity arising through shutting off fishing (Fzero) are greater than in Ecol1, for P/B and B/E indices. In this case, the most mature ecosystem is not necessarily the one with the most slow-lived marine mammals.

It is worth noting that, in this model, the increase of the cod fishery led to the elimination of skates through bycatch, which was followed by the increase in marine mammals (Table 5). If skates were not eliminated, they (or jellyfish, or any other ‘undesirable’ species) might easily replace cod in the Eastern Bering Sea instead of marine mammals, as evidenced by the changes which occurred after cod collapsed on the east coast of North America.

This result suggests the danger in choosing a measure of ecosystem stability (such as large numbers of P/B animals) without thorough investigation. While the elimination of cod to increase marine mammal populations does add slightly to system maturity, it is only ‘better’ than turning off fishing in that it coincides with our intuitive, subjective view of healthy ecosystems.

All of the indices of community structure should be examined closely with regard to the Ecosim optimization routines—it would be interesting to be able to optimize directly for some of Odum’s indices within the interface.

From the point of view of ecosystem stability, the existence of two ‘troughs’ of increasing maturity—one with cod and small flatfish eliminated from the system and one with a lower degree of fishing overall—suggests that this optimization routine, based on some type of ecosystem maximization, may be used to look for discrete states arising from possible “regime shifts” or system flips, which may occur if a system jumps from one mature state to another following a perturbation or environmental change.



## References

- Odum, E.P. 1969. The strategy of ecosystem development. *Science* 104: 262-270.
- Trites, A.W., Livingston, P.A., Vasconcellos, M.C., Mackinson, S., Springer, A.M., and Pauly, D. 1999. Ecosystem change and the decline of marine mammals in the Eastern Bering Sea: testing the ecosystem shift and commercial whaling hypotheses. *Fisheries Centre Research Reports*. 7 (1): 98 pp.
-

## A Preliminary North-East Atlantic Marine Ecosystem Model: the Faroe Islands and ICES Area Vb

**Dirk Zeller and Katia Freire**  
Fisheries Centre, UBC

### Abstract

This report documents the construction and input data of the first Ecopath with Ecosim model for the Faroe Islands marine ecosystem in the northeast Atlantic (ICES area Vb), covering the year 1997. The model comprises 19 functional groups, including two marine mammal groups and seabirds. The fisheries component consists of foreign fleets and national fleets, with an emphasis on demersal fisheries. Sustainable fisheries are of fundamental importance to the Faroe economy and culture. This model forms the foundation for future Ecosim and Ecospace simulations of the effect of fishing on the marine ecosystem around the Faroe Islands.

### Introduction

The Faroe Islands (human population ~46,000) are located in the North-East Atlantic between the British Isles and Iceland, and consist of a group of 18 islands covering 1,399 km<sup>2</sup>. While officially part of the Denmark, the Faroe Islands has held a special status since 1948, having been granted local autonomy. The major industries are fishing, sheep farming and cloth manufacturing, with fishing being the major export industry, equaling 44.5% of GDP and over 95% of all exports (<http://encarta.msn.com>). Commercial as well as subsistence fisheries play a significant role in Faroese culture and society (Anon. 1999a).

The waters surrounding the Faroe Islands are dominated by the North-Atlantic drift, which provides temperate waters throughout the year (Anon. 1999a). ICES Area Vb covers 190,200 km<sup>2</sup> and is subdivided into Vb1 (169,800 km<sup>2</sup>) which includes the Faroe Islands, Faroe plateau, Bill Baileys bank and areas of deep, pelagic waters, and Vb2 (20,400 km<sup>2</sup>) which contains the Faroe bank. The fisheries in the Faroe area can be characterized as multi-gear and multi-species (Anon. 1997). In 1994 the Faroe Islands introduced an ITQ-based management system, which was never successful, resulting in substantial increases in discarding and misreporting. Therefore, by mid 1996 a new management system based on individual transferable effort quotas (within same-gear categories only) and seasonally closed areas (spawning periods) was introduced (Anon. 1997, Anon. 1999b). Thus, the focus of the new man-

agement system has shifted from catch to effort (Anon. 1999a).

### Brief review of Faroe and ICES Area Vb fisheries

Cod stocks (*Gadus morhua*) and other demersal species form the most significant component for the Faroese fishing industry (Anon. 1999a). Since the establishment of the Faroese EEZ in 1977, the demersal fishery by foreign nations has decreased (Anon. 1999b) while the local fishing fleet underwent a period of over-investment in the 80s (Anon. 1999a). Cod stocks in Faroese waters were reported to have declined substantially from the mid-80s to mid-90s, due to environmental effects and to overfishing (Anon. 1999a). Fishing mortalities for cod increased considerably in the 80s, but more recently have declined to close to proposed levels (Anon. 1999b). Fishing mortalities for saithe (*Pollachius virens*) increased considerably during the last few decades, primarily due to the introduction of pair-trawlers, but since 1995 have been decreasing steadily. Fishing mortalities on haddock (*Melanogrammus aeglefinus*) have been very low since the 80s, a result of very low stocks and poor recruitment. During the late 90s, however, fishing mortalities increased due to two strong recruitment year classes (Anon. 1999b). With respect to the demersal fisheries, the new effort management system aims for average fishing mortalities 0.45. This corresponds to an average annual catch of approximately 33% of the exploitable biomass (Anon. 1999b).

Blue whiting (*Micromesistius poutassou*), Norwegian spring spawning herring (*Clupea harengus*) and mackerel (*Scomber scombrus*) form the main components of the pelagic fisheries (both foreign and Faroese fleets) in ICES Area Vb. Blue whiting are caught from the Barents Sea to the Strait of Gibraltar, and the stock is considered to have been relatively constant since the early 1980s, though estimates of abundance are imprecise (Anon. 1997). The total 1997 landings of blue whiting in all ICES areas exceeded management advice by nearly 15% (Anon. 1998a). Average fishing mortality has been estimated at 0.325, and a projected increase to 0.4 is beyond the suggested safe level (Anon. 1998a). In Area Vb, blue whiting are caught primarily by Russia and Norway, with only ~4% of the 1997 catch taken by Faroese vessels (ICES STATLANDT).

In contrast, over 90% of the total herring catch in Area Vb was taken by Faroese vessels in 1997. Overall, the fisheries on the Norwegian spring spawning herring stock imposed a fishing mortality of 0.19 in 1997 (Anon. 1999c). Nearly 40% of

**Table 1.** Ecopath parameters used to describe the preliminary 1997 ICES Area Vb (Faroe Islands) marine ecosystem with 20 functional groups. P/B and Q/B are the production/biomass and consumption/biomass ratios, respectively.

Group	Biomass (t km <sup>-2</sup> )	P/B (year <sup>-1</sup> )	Q/B (year <sup>-1</sup> )	Ecotrophic efficiency	Catch (t km <sup>-2</sup> )	Trophic level	Vulnerability parameter
Baleen whales	0.059	0.05	5.059	0.069	-	3.9	0.7
Toothed mammals	0.034	0.05	12.266	0.981	-	4.6	0.9
Seabirds	0.017	0.01	35	0.000	-	3.8	0.7
Cod	0.57	0.653	3.1	0.638	0.20	4.1	0.8
Haddock	0.723	0.346	3.8	0.660	0.09	3.6	0.7
Saithe	0.611	0.443	3.3	0.739	0.12	4.1	0.8
Redfish	2.133	0.35	4.5	0.552	0.04	3.7	0.7
Greenland Halibut	0.109	0.446	3.5	0.950	0.03	3.6	0.7
Other dem.sal fish	1.869	0.45	3	0.950	0.03	3.7	0.7
Other deep water	0.765	0.35	3.1	0.950	0.10	4.1	0.8
Herring	1.903	0.296	4.6	0.949	0.10	3.4	0.6
Blue Whiting	3.557	0.355	9.06	0.950	0.57	3.6	0.7
Mackerel	1.03	0.276	4.4	0.950	0.06	3.7	0.7
Other pelagics	9.641	0.585	4.5	0.947	0.02	3.2	0.6
Benthos	9.259	3.0	10	0.950	0.02	2.5	0.4
Nekton	4.647	0.6	3.5	0.950	-	3.6	0.7
Large Zooplankton	16.193	7.763	40	0.950	-	2.6	0.5
Small Zooplankton	11.526	40	140	0.950	-	2.1	0.3
Phytoplankton	54.36	50	-	0.682	-	1.0	0.1
Detritus	-	-	-	0.027	-	1.0	0.1

the mackerel catches in Area Vb during 1997 were taken by the local fleet. The other major nations catching mackerel in this area were Russia, Denmark, Estonia and the U.K. (ICES STATLANDT). Average fishing mortalities for the complete North-East Atlantic mackerel stock varied from a high of 0.25 in the mid 1980s to a low of 0.19 in 1991, before increasing again to 0.25 in the mid 90s (Anon. 2000). Mackerel are considered to be outside of safe biological limits and ICES advises significant reductions in fishing mortalities (Anon. 1997).

The deep-water fisheries catch consists of species such as Greenland halibut (*Reinhardtius hippoglossoides*), redfish (*Sebastes* spp.), silver smelt (*Argentina* spp.), ling (*Molva molva*) and others. The long life-span and associated low rate of increase of many of these species means that catches can be sustained for a number of years as the stocks are 'mined' before suddenly collapsing (Anon. 1997). The deepwater fisheries in ICES Area Vb were separated into three components for the present modelling attempt: redfish, Greenland halibut and other deep water species. Total landings from ICES Vb for 1997 were over 34,000 tonnes, of which the Faroese fleets took over 97% of the Greenland halibut and redfish catch, and 78% of the other deep water species.

### Ecosystem model

An ecosystem model of the Faroese waters (based on ICES Area Vb) was constructed using the latest test version of Ecopath with Ecosim (4.0 beta, www.ecopath.org). The present model is a prelimi-

nary version, and much of the data used had to be obtained from indirect sources and areas that are close to, but not identical to ICES Area Vb (i.e. non-Faroe area data). The authors, in collaboration with scientists from the Faroe Islands, are in the process of updating the present model to incorporate more suitable, Faroe-area specific data. The parameterized Ecopath input data used are summarized in Table 1, and sources for the group specific information are summarized in Table 2. The emphasis of the subsequent simulations initiated during the FAO sponsored workshop at UBC were to explore the new open and closed loop fisheries policy search routines in Ecosim using three extreme scenarios (economic, social and ecosystem stability) and an initial attempt to simulate a potential compromise scenario.

### Fishing fleet information

Landings for 1997 by species for all fleets in ICES Area Vb were obtained from the ICES STATLANDT database. No information on discards is currently incorporated into the model. All non-Faroese fleets (mainly Iceland, Norway, Russia, United Kingdom, Germany, France, Denmark and Estonia) were pooled into a single "Foreign" category (Table 3). The Faroese fleets were separated by gear according to the ICES NWWG report (Anon. 1999b) and the Faroe Fisheries Laboratory report (Anon. 1998e), with the following changes: 1) addition of a 'Pelagic' gear type accounting for all Faroese catches of pelagic species, 2) pooling of 'Industrial' and 'Others' gear type due to low catches.

**Table 2.** Sources of input parameters for the Faroe Islands Ecopath with Ecosim Model. Dash means parameters estimated by the model.

GROUP	B	P/B	Q/B	EE	Diet
1. <b>Baleen whales:</b> <i>Balaenoptera acutorostrata</i> , <i>B. borealis</i> , <i>B. physalus</i> , <i>Megaptera novaeangliae</i> (www.wildlife.shetland.co.uk)	Trites & Pauly, 1998 Pauly et al. 1998	Iceland, Mendy (1997) V.Christensen pers. com.	Trites & Pauly, 1998 Pauly et al. 1998	—	Trites & Pauly, 1998 Pauly et al. 1998
2. <b>Toothed mammals:</b> seals ( <i>Halichoerus grypus</i> , <i>Phoca vitulina</i> ); dolphins ( <i>Lagenorhynchus acutus</i> , <i>L. albirostris</i> , <i>Phocoena phocoena</i> , <i>Grampus griseus</i> ); whales ( <i>Globicephala melas</i> , <i>Orcinus orca</i> , <i>Physeter catodon</i> ) (www.wildlife.shetland.co.uk)	Trites & Pauly 1997, 1998 Pauly et al. 1998	Iceland, Mendy (1997) V.Christensen pers. com.	Trites & Pauly 1997, 1998 Pauly et al. 1998	—	Trites & Pauly 1997, 1998 Pauly et al. 1998
3. <b>Seabirds</b>	Iceland, Mendy (1997) Anon. 1998c, Anon. 1999e	Iceland, Mendy (1997) Anon. 1998c, Anon. 1999e	Iceland, Mendy (1997) Anon. 1998c, Anon. 1999e	—	Iceland, Mendy (1997)
4. <b>Cod:</b> <i>Gadus morhua</i>	ICES single sp. VPA: Anon. 1998b, Anon. 1999b	ICES single sp. VPA: Anon. 1998b, Anon. 1999b	Iceland, Mendy (1997)	—	Iceland, Mendy (1997): adjusted with data from (Du Buit 1989)
5. <b>Haddock:</b> <i>Melanogrammus aeglefinus</i>	ICES single sp. VPA: Anon. 1998b, Anon. 1999b	ICES single sp. VPA: Anon. 1998b, Anon. 1999b	Iceland, Mendy (1997)	—	Iceland, Mendy (1997): adjusted with data from (Du Buit 1989)
6. <b>Saithe:</b> <i>Pollachius virens</i>	ICES single sp. VPA: Anon. 1998b, Anon. 1999b	ICES single sp. VPA: Anon. 1998b, Anon. 1999b	Iceland, Mendy (1997)	—	Iceland, Mendy (1997): adjusted with data from (Du Buit 1989)
7. <b>Redfish:</b> <i>Sebastes</i> spp.	Iceland, Mendy (1997)	Iceland, Mendy (1997)	Iceland, Mendy (1997)	-----	Iceland, Mendy (1997)
8. <b>Other deep water fishes:</b> angler ( <i>Lophius piscatorius</i> ), black scabbardfish ( <i>Aphanopus carbo</i> ), silver smelt ( <i>Argentina</i> spp.); tusk ( <i>Brosme brosme</i> ), greater forkbeard ( <i>Phycis blennoides</i> ), Roundnose grenadier ( <i>Coryphaenoides rupestris</i> ), roughhead grenadier ( <i>Macrourus berglax</i> ), megrim ( <i>Lepidorhombus whiffiagonis</i> ), orange roughy ( <i>Hoplostethus atlanticus</i> ), blue ling ( <i>Molva dypterygia</i> ), ling ( <i>M. molva</i> ) (V.Christensen pers.com.)	(V. Christensen pers.com.)	(V. Christensen pers.com.)	(V. Christensen pers.com.)	(V. Christensen pers.com.)	Anon. 1998d, Bjelland & Bergstad 1998
9. <b>Greenland Halibut:</b> <i>Reinhardtius hippoglossoides</i>	ICES VPA: Anon. 1999b	ICES VPA: Anon. 1999b	Iceland, Mendy (1997)	V. Christensen pers.com.	Iceland, Mendy (1997): adj. for herring & blue whiting (Michalsen & Nedreass 1998).
10. <b>Other demersal fishes</b>	Iceland, Mendy (1997)	Iceland, Mendy (1997)	Iceland, Mendy (1997)	Iceland, Mendy (1997)	Iceland, Mendy (1997)
11. <b>Herring:</b> <i>Clupea harengus</i>	ICES single sp. VPA for Areas V and XIV: adjusted to Area Vb (Holst et al. 1998, Anon. 1999c).	ICES single sp. VPA for Areas V and XIV: adjusted to Area Vb (Holst et al. 1998, Anon. 1999c).	Iceland, Mendy (1997)	Iceland, Mendy (1997)	Christensen (1995) V. Christensen pers.com.
12. <b>Blue whiting:</b> <i>Micromesistius poutassou</i>	ICES single sp. VPA: Anon. 1999c	ICES single sp. VPA: Anon. 1999c	www.fishbase.com	(V. Christensen pers.com.)	www.fishbase.com
13. <b>Mackerel:</b> <i>Scomber scombrus</i>	Single sp. VPA (western stock): Anon. 2000	Single sp. VPA (western stock): Anon. 2000	www.fishbase.com	(V. Christensen pers.com.)	North Sea (Christensen 1995) Western Atlantic (Studhome et al. 1999)
16. <b>Nekton:</b> cephalopods	Iceland, Mendy (1997)	Iceland, Mendy (1997)	Iceland, Mendy (1997)	Iceland, Mendy (1997)	V. Christensen pers.com.
17. <b>Large zooplankton:</b> large amphipods, copepods (e.g., <i>Calanus finmarchicus</i> ), euphausiids ( <i>Thysanoessa</i> spp.). Dry weight biomass for SW Iceland (Gislason & Astthorsson 1995); DW = 0.26*WW; Opitz (1996); adj. to ICES Area Vb	(V. Christensen pers. com.)	(V. Christensen pers. com.)	(V. Christensen pers. com.)	(V. Christensen pers. com.)	(V. Christensen pers. com.)
18. <b>Small zooplankton</b>	(V. Christensen pers. com.)	(V. Christensen pers. com.)	(V. Christensen pers. com.)	(V. Christensen pers. com.)	(V. Christensen pers. com.)
19. <b>Phytoplankton</b>	P from Loughurst et al. (1995); conv. wet wt Pauly & Christensen (1995).	Iceland, Mendy (1997)	—	—	—

**Table 3.** Fishing fleets and weighing factors used for weighing social employment values in the Ecopath with Ecosim model. Breakdown of Faroese demersal fleet is based on ICES NWWG report (Anon. 1999b).

Fleet/gear type	Scenarios	
	Extreme Jobs /catch	Compromise Jobs/ catch
Foreign	1	1
Open boat	10	2
Longline max 100t	5	2
Longline > 100t	5	2
Single trawl max 400hp	1	2
Single trawl 400-1000hp	1	2
Single trawl > 1000hp	1	2
Pair trawl max 1000hp	1	2
Pair trawl > 1000hp	1	2
Gillnet	5	2
Jigger	5	2
Others	5	2
Pelagic	1	2

ICES catches were allocated to Faroese gear types according to the percentage distributions of landings documented in Anon. (1998e). Fish prices (market price) for each species/group was obtained from Fish Information Service ([www.fis.com](http://www.fis.com)). For Faroese landings, market prices from Faroese markets were used; for foreign fleets, market prices for Danish, Icelandic and Norwegian markets were averaged. All prices are reported in US\$ kg<sup>-1</sup> based on June 2000. For non-single species groups, prices for group members were averaged to derive average group market prices. The assumed discount rate is 4%, and non-market values have not been considered.

Costs (by gear type) are approximated from Anon. (1994) and expressed as a percentage of the total landed value. However, these costs are based on Canadian fisheries and location specific information is required.

### Simulations

Each Ecosim simulation was run for a 30-year period, and repeated for 4 different vulnerability (flow control) settings (0.1, 0.4, 0.7, and variable). Variable vulnerability (vv) values were obtained by linear interpolation based on the trophic level for each group, with the highest trophic level group (toothed mammals 4.6) being set at  $v=0.9$  and phytoplankton (trophic level=1.0) being set at  $v=0.1$  (Table 1). For simplicity of reporting and comparison between scenarios within the framework of this report, we concentrated on results obtained under  $v=0.7$  and variable vulnerability settings. Furthermore, higher vulnerabilities imply lower resilience to overfishing (S. Martell pers. com.), hence assuming higher vulnerabilities applies the precautionary principle for policy decisions.

The weighting for the policy search criteria for each extreme scenario were: economic optimization weighted only for net economic value; ecosystem stability optimization weighted for maximizing mammal and seabird biomass and using the reciprocal of the P/B ratios as importance weights for each group; and social optimization weighted to maximize jobs/catch (approximated by maximizing landings). For the extreme social scenario, highest weighting was given to the open boat sector within the demersal fleet, followed by longliners, jigger, gillnet and others (Table 3). For each extreme scenario, the relevant value component was set to value weight = 1 (e.g., economic), while the other two value components (e.g., ecosystem and social) approximated zero (0.0001).

For the 'compromise' scenario, all three value components were equally weighted. Additionally, social weighing for each fleet (jobs/catch) was equal within the Faroese fleets, and twice the weight given to foreign fleet (Table 3). Furthermore, ecosystem stability weights were set equally for all groups (rather than heavily weighted towards mammals and birds) with an ideal biomass twice Ecopath baseline. The variables we compared among scenarios were changes in total catch, value and biomass over the 30 year simulation period, and, if applicable, we considered changes in individual species/groups and fleet components.

#### *Economic value optimization (extreme)*

Under the conditions of purely maximizing net economic gain from the system, total value over the 30-year period could be increased by 156%, with a concurrent increase in total catch and total biomass of 38% and 11%, respectively (Table 4). This was to be achieved through 6- and 2-fold increase in fishing effort by the pelagic and single-trawl fleets, while other gears were to be shut down (e.g. pair-trawl, gillnet) or to be increased by 20-50% (e.g. long-line, foreign; Table 5).

**Table 4.** Percentage change in catch, value and biomass for the three simulated extreme scenarios under vulnerability conditions for all groups of  $v = 0.7$ , and the single compromise scenario considered (variable vulnerability). For comparison, variable vulnerability results for each extreme scenario are listed in brackets.

Scenario	Catch (%)	Value (%)	Biomass (%)
Economic extreme	38 (3)	156 (39)	11 (1)
Ecosystem stability extreme	-23 (-42)	35 (-3)	10 (6)
Social extreme	60 (8)	183 (85)	15 (1)
Compromise	6	109	2

**Table 5.** Results of open loop fishing policy search routine in Ecosim. Values indicate relative change in fishing effort for each fleet/gear type in relation to Ecopath baseline.

Scenario	Baseline Vulnerabilities	Economic		Ecosystem		Social		C'promise
		0.7	Vv	0.7	Vv	0.7	Vv	Vv
Foreign	1.0	1.5	1.1	4.1	7.2	6.6	6.5	0.1
Open boat	1.0	1.3	19	1.1	1.1	20.1	20	0.5
Longline max 100t	1.0	1.2	0.1	0.4	4.8	0.3	0.3	0.0
Longline > 100t	1.0	1.2	0.1	0.4	4.8	0.3	0.3	0.0
Singletrawl max 400hp	1.0	2.1	2.8	2.5	2.7	0.0	0.0	20
Singletrawl 400-1000hp	1.0	2.1	2.8	2.5	2.7	0.0	0.0	20
Singletrawl > 1000hp	1.0	2.1	2.8	2.5	2.7	0.0	0.0	20
Pairtrawl max 1000hp	1.0	0.0	0.0	2.6	0.8	0.0	0.0	0.0
Pairtrawl > 1000hp	1.0	0.0	0.0	2.6	0.8	0.0	0.0	0.0
Gillnet	1.0	0.1	0.1	0.5	0.7	1.1	21	0.2
Jigger	1.0	0.1	0.1	1.2	1.6	0.1	0.1	0.1
Others	1.0	0.6	0.7	0.6	1.2	0.9	0.9	1.5
Pelagic	1.0	6.1	2.2	0.5	0.3	22.4	32	20

However, under conditions of maximizing economic value alone (with assumed vulnerability of  $v=0.7$ ), the dynamics of the simulations appeared unstable. Several groups were being depleted severely in biomass, including mackerel, herring, blue whiting (all by over 95%), Greenland halibut (~80%), other demersal fish (~70%), haddock (~40%), redfish and toothed mammals (~30%). Three groups (cod, saithe and other pelagics), however, showed a drastic increase in biomass (397%, 209%, 192%). Cod and other pelagics were driving the increase in total value (34%, 256%).

Simulated changes in total catch, value and biomass would be smaller under conditions of variable vulnerabilities (bracketed values in Table 4). Overall, the simulations indicated a more stable system compared to assumed vulnerability of 0.7. Policy recommendations were similar to the above scenario, except that the open boat fleet was to receive an 18-fold increase in effort, while the longline sector was to be essentially eliminated (Table 5). Biomass of mackerel, Greenland halibut and blue whiting were decreased by approximately 80%, 70% and 60%, respectively, while saithe biomass was predicted to increase by ~100%.

*Ecosystem stability optimization (extreme)*

Under the extreme ecosystem scenario (heavily weighted towards mammals and seabirds), toothed mammal, baleen whale and seabird biomass were increased by 60%, 40% and 2%, respectively, while total biomass only increased by 10% (Table 4). Total value increased by 35% with a concurrent drop in total catches by 23%. The fishing policy recommendations were to increase both single- and pair-trawl gears by 150% and 160%, respectively, while the foreign fleet sector was to be boosted by a factor of 4 (Table 5). Other gear types were to be maintained or reduced by

approximately 50%. As a result, saithe and blue whiting were simulated to be commercially extinct (-100%), while cod and other deep water species biomass was expected to drop by 50%.

Under assumed conditions of variable vulnerabilities, total biomass would have increased by only 6%, while both catch and value would have been reduced (Table 4). However, biomass of toothed mammals, baleen whales and seabirds would have increased by 41%, 26% and 14%, respectively. The overall reduction in total catch and value were clearly driven by a 100% biomass loss for blue whiting, cod and haddock, and a 95% reduction in mackerel biomass. Increases of 130% for herring and other pelagics, and 70% for Greenland halibut did not offset the fisheries performance. Policy recommendations included a 7-fold increase of the foreign fleet effort, nearly 5-fold increase in long-line and 3 fold increase in single-trawl activities, as well as a marginal reduction in pair-trawl and gillnet effort (Table 5). Clearly, such a 'reduced' system is, in reality, likely to be less stable at an ecosystem level, even given sole emphasis on whales and seabirds.

*Social value optimization (extreme)*

Under the scenario targeted at maximizing catch (max. social employment target), total catch was indeed increased by 60%, while total value was improved by 183% and total biomass by 15% (Table 4). Severe depletion of several groups did, however, occur. The main pelagic species, mackerel, herring and blue whiting were reduced by 100%, while other demersal fishes and Greenland halibut were reduced by 85% and 50%, respectively. Clearly, the increase in total biomass was due to 400% and 230% increases in cod and saithe biomass. The observed pattern was the result of a policy optimization resulting in 20-fold increases in the open boat and pelagic gear types,

a 6-fold increase in foreign fleet effort, with a concurrent reduction or phasing out of most other gear types (Table 5).

### Compromise optimizations

The overall results for the compromise scenario suggested a 109% increase in total value accompanied by a 6% increase in total catch (Table 4). This was achieved through boosting singletrawl and pelagic fleets by a factor of 20, while essentially removing most of the other gear types (Table 5). At a species (or group) level, this scenario does also lead to the depletion or severe reduction in biomass of several species. Blue whiting, other deep water and Greenland halibut groups are reduced by 90-100%, while redfish, mackerel and herring biomass are expected to drop by 40-50%.

Thus, while the compromise scenario does manage to obtain increases in all three parameters (value, catch and biomass) at the total level, the results would not be acceptable from a multi-species, multi-fleet perspective. Clearly, more appropriate values, particularly for the social employment values, are required, before a better long-term balance between the three value components (economic, social and ecosystem stability) can be attempted.

### Simulation of optimal fishing policy incorporating uncertainties

Using the closed loop policy simulation module in Ecosim, we evaluated the change in performance of each derived fishing policy under conditions of uncertainty in annual stock size estimation (20% coefficient of variation for biomass estimates) and annual catchability increases (max. increase of 10% year<sup>-1</sup>). The percentage values presented in Table 6 represent the performance of the closed loop simulations (10 runs each) relative to the baseline Ecosim fishing policy simulation under conditions of perfect knowledge (*sensu* Martell *et al.* this volume). Thus, values larger than 100% indicate improved performance by the simulated management under uncertainty, and values less than 100% indicate poorer performance compared to conditions of perfect knowledge. For example, under conditions of uncertainty, performance was always poorer for social values (between 33% and 49% poorer, Table 6). Interestingly, these simulations suggested that the performance under conditions of uncertainty was 95% and 171% better for net economic values within the ecosystem and social extreme scenarios, respectively, while performance was 7% poorer when trying to maximize for economic return. Surpris-

**Table 6:** Performance comparison of policy implementation simulation under conditions of uncertainty. Percentage values represent the fraction of the performance compared to the open loop policy benchmark (i.e., without uncertainty, variable vulnerabilities only).

Scenario	Net econ. value (%)	Social value (%)	Ecosystem stability(%)
Economic extreme	93	65	100
Ecosystem stability extreme	195	67	100
Social extreme	271	61	100
'Big Compromise'	144	66	100

ingly, under conditions of uncertainty no improvements in ecosystem stability values could be obtained for either scenario. At this stage in the development of the current Ecopath model we have little confidence in the present results (see conclusions below). Furthermore, we cannot explain why, under conditions of uncertainty, we observed such a dramatic increase in economic performance for the ecosystem stability, social values and compromise scenarios.

### Conclusions

The aim of this exercise was to test the new policy search routines in Ecosim using three extreme scenarios and a potential compromise setting. Given the preliminary nature of the underlying Ecopath model for ICES Area Vb and Faroe Islands, none of the present outcomes should be considered practical or representative. In many of the simulated scenarios, the suggested optimal policies were extreme (e.g., increasing fishing power of one fleet by 20 fold, while completely removing other fleets), generally resulting in biomass responses by the ecosystem model that lead to severe depletion of many groups. This applied even to the attempted compromise scenario. Three conclusions can be drawn from these findings. Firstly, our underlying Ecopath model might not yet be representative of the ecosystem as related to the established fishing patterns in ICES Area Vb. Secondly, considerable fine-tuning of the compromise policy scenario might be required, through more realistic application of social and ecosystem value scores. And thirdly, as the version of the Ecosim routine used during the workshop was a test version, it is likely that some computational problems might still have resided in the program. Updating and corrections of the routine is ongoing (V. Christensen pers. com.).

Currently we are in the process of updating the Ecopath parameters to location specific values, including fisheries fleet data, employment values, as well as time series data. Future steps should include using time series data as forcing functions to derive more realistic vulnerability values for the major groups, as well as being able to account for environmental changes, prior to re-examining realistic policy options for forward projections

(e.g., see Martell *et al.* this volume). Any potential policy scenarios will be attempted in collaboration with scientists from the Faroe Islands, in order to incorporate local considerations and knowledge.

The society and economy of the Faroe Islands is highly dependent on fisheries as the major export earner. Thus, the Faroe society is highly vulnerable to fluctuations in stocks and hence catch, making efficient management strategies a priority (Anon. 1999). This is particularly relevant, as most commercial species are considered fully or over-exploited (Anon. 1997, 1999). This situation has been brought about largely by long-term overfishing in most areas of the north-east Atlantic, although environmental factors may have played a significant role in a few stocks (Anon. 1997). At the same time, this high dependence on what is essentially a mono-economy, should result in over-cautious management scenarios being increasingly proposed. We consider that, once location specific data and time series information have been incorporated into the present Ecopath with Ecosim model, more realistic management scenarios can be simulated and evaluated that might point to policies that can lead to increased landings and economic yields, with improved stability in catches and reduced risk of stock collapse.

## References

- Anon. 1994. Report on fishing vessel performance: Scotia-Fundy fisheries - Maritime Region. Economic Analysis Division, DFO Canada. Economic and Commercial Analysis Report No. 152:38pp.
- Anon. 1997. Review of the state of world fishery resources: marine fisheries. FAO Fisheries Circular No. 920 FIRM/C920 (ISSN 0429-9329), Rome, FAO, 173 pp.
- Anon. 1998a. Report of the northern pelagic and blue whiting fisheries working group. ICES CM 1998/ACFM:18.
- Anon. 1998b. Report of the north-western working group. ICES CM 1998/ACFM:19.
- Anon. 1998c. Report of the working group on seabird ecology. ICES CM 1998/C:5.
- Anon. 1998d. Report of the study group on redfish stocks. ICES CM 1998/G:3.
- Anon. 1998e. Fiskastovnar og umhvorvi 1998. Lagt til raettis: Fiskirannsóknarstovan. Faroe Islands Fisheries Laboratory. [www.frs.fo/fiskif/fiskogum/index.htm](http://www.frs.fo/fiskif/fiskogum/index.htm).
- Anon. 1999a. Fishery Country Profile: Faroe Islands. FID/CP/FRO Rev. 3. Rome, FAO. [www.fao.org/fi/fcp/faroeise.asp](http://www.fao.org/fi/fcp/faroeise.asp).
- Anon. 1999b. Report of the north-western working group. ICES CM 1999/ACFM:17.
- Anon. 1999c. Report of the northern pelagic and blue whiting fisheries working group. ICES CM 1999/ACFM:18.
- Anon. 1999d. Report of the study group on the biology and assessment of deep-sea fisheries resources. ICES CM 1999/ACFM:21.
- Anon. 1999e. Report of the working group on seabird ecology. ICES CM 1999/C:5.
- Anon. 2000. Report of the working group on the assessment of mackerel, horse mackerel, sardine and anchovy. ICES CM 2000/ACFM:5.
- Bjelland, O. and Bergstad, O.A. 1998. Trophic ecology of deepwater fishes associated with the continental slope of the eastern Norwegian Sea. ICES CM 1998/O:51.
- Christensen, V. 1995. A model of trophic interactions in the North Sea in 1981, the Year of the Stomach. Dana 11(1):1-28.
- Du Buit, M.H. 1989. Quantitative analysis of the diet of cod (*Gadus morhua*) off the coast of Scotland, Ann. Inst. Ocean. Paris 65(2):147-158.
- Gislason, A. and Astthorson, O.S. 1995. Seasonal cycle of zooplankton southwest of Iceland. J. Plankton Res. 17(10):1959-1976.
- Holst, J.C., Arrhenius, F., Hammer, C., Hakansson, N., Jacobsen, A., Krysov, A., Melle, W. and Vilhjalmsson, H. 1998. Report on surveys of the distribution, abundance and migrations of the Norwegian spring-spawning herring, other pelagic fish and the environment of the Norwegian Sea and adjacent waters in late winter, spring and summer of 1998. ICES CM 1998/D:3.
- Longhurst, A.R., Sathyendranath, S., Platt, T. and Caverhill, C.M. 1995. An estimate of global primary production in the ocean from satellite radiometer data. J. Plankton Res. 17: 1245-1271.
- Mendy, A. 1997. Trophic modeling as a tool to evaluate and manage Iceland's multispecies fisheries. Report of the Marine Research Institute of Iceland. MS in prep.
- Michalsen, K; Nedreaas, KH 1998. Food and feeding of Greenland halibut (*Reinhardtius hippoglossoides*), Sarsia 83(5):401-407.
- Opitz, S. 1996. Trophic interactions in Caribbean reefs. ICLARM Tech. Rep. 43:341pp.
- Studhome, A., Packer, D., Berrien, P., Johnson, D., Zetlin, C. and Morse, W. 1999. Essential fish habitat source document: Atlantic mackerel, *Scomber scombrus*, life history and habitat characteristics. NOAA Technical Memorandum NMFS-NE-141, 35 pp.
- Pauly, D., Trites, A.W., Capuli, E. and Christensen, V. 1998. Diet composition and trophic levels of marine mammals. ICES J. mar. Sci. 55:467-481.
- Trites, A.W. and Pauly, D. 1998. Estimating mean body masses of marine mammals from maximum body lengths. Can. J. Zool. 76:886-896



## Policy Simulation of Fisheries in the Hong Kong Marine Ecosystem

Wai-Lung Cheung<sup>1</sup>, Reg Watson<sup>2</sup> and Tony Pitcher<sup>2</sup>

<sup>1</sup> Department of Ecology and Biodiversity, University of Hong Kong

<sup>2</sup> Fisheries Centre, UBC

### Abstract

Alternative fishery management policies under different policy objectives for the 1990s Hong Kong waters ecosystem were explored using a newly developed simulation model named 'policy simulator' under the Ecopath with Ecosim software. Scenarios, which aim to maximize the economic output, the social output, the ecological output, and a compromise between the above three outputs were simulated under different vulnerability settings. Results suggested that policy simulations that aimed to maximize economic and social strategy were sensitive to vulnerability setting. Results from simulations aimed to maximize ecological stability and the compromise scenario are generally consistent between different vulnerabilities, and suggested that fishing effort of all fishing sectors and all except P4/8 fishing sectors, respectively, should be reduced. The study also demonstrated that the economic and social outputs decrease when policy objective focuses increasingly on maximizing ecological stability. The results are consistent with general observations of fisheries management. It is suggested that the "policy simulator" offers excellent insights into management trade-offs in an ecosystem context.

### Study Area

Hong Kong is situated at 22 °N and 114.3 °E, in southeastern China on the eastern shores of the Pearl River estuary. It has a sub-tropical monsoon climate, with average winter (December to February) and summer (June to September) temperatures of 15 and 27 °C respectively. Annual average water temperature is about 23°C. Winter is dry while summer is wet. Hong Kong territorial waters, here referred to as Hong Kong waters (Figure 1), are influenced by the outflow of freshwater from the Pearl River in the west, and oceanic currents in the east (Morton and Morton, 1986). In the winter, the Kuroshio Current brings in high salinity and high temperature water from the Pacific through Luzon Straits, while the Taiwan current from the East China Sea brings in water with reduced salinity and temperature. In summer, the Hainan Current with high salinity and variable temperature water moves past Hong Kong towards Taiwan. These seasonal conditions create a wide range of habitat types for the diverse marine

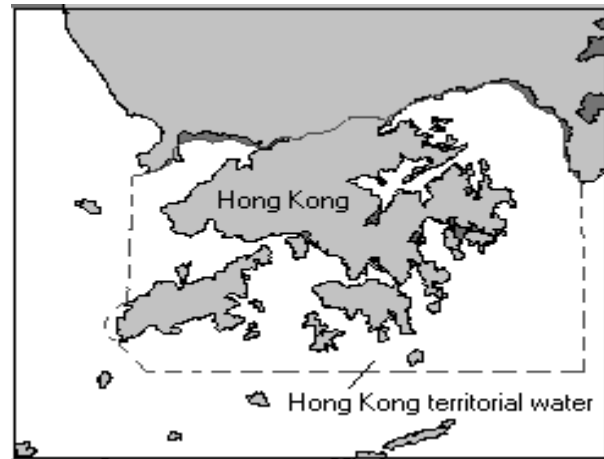

**Figure 1.** Map of Hong Kong and the adjacent waters. The area within the broken line represents the territorial waters of Hong Kong.

flora and fauna. There are around 50 species of zooxanthellate corals (Morton, 1994) and more than 800 species of fishes, of which reef fishes constitute more than 300 (Ni and Kwok, 1999; Sadovy and Cornish, 2000).

These marine resources are exploited commercially by capture fisheries.

### Brief overview of Hong Kong's fisheries

In Hong Kong, marine capture fisheries supply a great local marine fish demand. This high demand is mainly created from the high consumption rate of fisheries products in Hong Kong. It was estimated that 46 kg of fisheries products per capita per year were consumed (AFD 1996), which was seven times more than the consumption rate of the residents of United States and second only to Japan (EVS, 1996).

Dramatic expansion of the Hong Kong marine capture fisheries took place in the later half of the 20<sup>th</sup> century with rapid mechanization supported by the government. Additionally, modern trawlers were introduced in the 1960s to replace the traditional style trawlers (Stather, 1975). At the same time, other fishing technologies such as onboard refrigeration, ultra-sounder, and other navigation technology were being developed.

Fishery resources in Hong Kong waters were mainly exploited by trawls (pair trawl, stern trawl, shrimp trawl and pelagic hang trawl), purse seines, and a mixture of gillnets, fish traps, hook and line (hand-line and long-line) usually with small fishing boats. Multi-species stocks were exploited, with both reef and estuarine species well represented in the catches. Large predatory fishes including groupers (Serranidae), snapper (Lut-

**Table 1.** Summary of parameters input in the present-day Hong Kong marine ecosystem model. Italics and light shading show parameters that are estimated to balance the model. RA = reef associated; NRA = non-reef organisms.

Group no.	Functional groups	Biomass (t/km-2)	P/B /year	Q/B /year	EE	P/Q	
1	Benthic producers	153 <sup>a</sup>	11.885 <sup>b</sup>	-	0.008	-	a – Silvestre <i>et al.</i> (1993) for Brunei Darussalam, South China Sea
2	Phytoplanktons	13 <sup>b</sup>	231 <sup>b</sup>	-	0.772	-	b – Pauly and Christensen (1995) for the South China Sea
3	Zooplanktons	14.7 <sup>b</sup>	32 <sup>b</sup>	192 <sup>b</sup>	0.081	0.167	c – Bucharly (1999) for the Java Sea, Indonesia
4	Jellyfish	0.032	5.011 <sup>b</sup>	25.05 <sup>b</sup>	0.95	0.200	d – Tsui <i>et al.</i> (1989), Daya Bay, South China Sea survey
5	Living BottomSt.	17.184	0.1 <sup>c</sup>	0.5 <sup>c</sup>	0.95	0.200	e – Greze and Kinne (1978)
6	Small Zoobenthos	70.37 <sup>d</sup>	6.57 <sup>e</sup>	27.4 <sup>c</sup>	0.409	0.240	f – Adjusted for balancing the model
7	Macrozoobenthos	3.1 <sup>f</sup>	3.2 <sup>a</sup>	12.5 <sup>c</sup>	0.993	0.256	g – Pitcher <i>et al.</i> (1998), earlier Hong Kong model
8	Bent. Crust. NR	0.304	5.65 <sup>g</sup>	17.82 <sup>h</sup>	0.95	0.317	h – Arreguin-Sanchez <i>et al.</i> (1993), northern continental shelf of Yucatan, Gulf of Mexico.
9	Bent. Crust. RA	1.217	1.85 <sup>h</sup>	8.35 <sup>h</sup>	0.95	0.222	i – Alino <i>et al.</i> (1993) Bolinao coral reef, Philippines model
10	Pen. prawns NRA	0.72 <sup>g</sup>	5.98 <sup>g</sup>	16.352 <sup>i</sup>	0.953	0.366	j – Browder (1993) Gulf of Mexico continental shelf model
11	Peneid prawns RA	0.172 <sup>g</sup>	7.6 <sup>g</sup>	41.537 <sup>i</sup>	0.99	0.183	k – Assumed to be the same as small demersal reef-associated fish
12	Elasmobranch	0.022	0.5 <sup>k</sup>	7.93 <sup>k</sup>	0.95	0.063	l – Pauly's empirical equation (Pauly <i>et al.</i> , 1990)
13	Cephalopods NRA	0.316	3.1 <sup>b</sup>	11.97 <sup>i</sup>	0.95	0.259	m – Arbitrarily set
14	Cephalopods RA	0.12	3.1 <sup>b</sup>	11.97 <sup>i</sup>	0.95	0.259	n - Assumed to be the same as small demersal non reef-associated fish
15	LBS-assoc. fish Ad	0.23	1.2 <sup>c</sup>	9.28 <sup>c</sup>	0.95	0.129	o - Trites <i>et al.</i> , (1997)
16	LBS-assoc. fish Ju	0.454	4.14 <sup>g</sup>	10.47 <sup>k</sup>	0.95	0.395	p - Reilly and Barlow (1986)
17	Sm. Demersal RA	0.85 <sup>g</sup>	4.2 <sup>g</sup>	10.47 <sup>i</sup>	0.98	0.401	q – Using formular from Trites and Heise (1996), i.e., $R = 0.1 * W^{0.8}$ ; and using the weight information from Pauly <i>et al.</i> (1995) and Trites and Pauly (1998)
18	Sm. Dem. NRA	0.935 <sup>g</sup>	4.2 <sup>g</sup>	10.89 <sup>i</sup>	0.998	0.386	r – Polovina (1984), French Frigate Shoals model
19	Med. Dem. RA	0.418	2.0 <sup>m</sup>	8.63 <sup>i</sup>	0.95	0.232	s – Jarre-Teichmann and Pauly (1993), Peruvian upwelling model
20	Med. Dem. NRA	0.402	2.0 <sup>m</sup>	8.63 <sup>i</sup>	0.95	0.232	t – Local species were identified using information collected by Melville (1984). The Q/B was estimated using weight data collated in Hoyo <i>et al.</i> (1992), using formula by Nilsson and Nilsson (1976)
21	Lg. Dem. RA Ad	0.578	0.9 <sup>c</sup>	5.11 <sup>i</sup>	0.95	0.176	u – Dalsgaard (1999), Enewetak Atoll model, Micronesia
22	Lg. Dem. RA Ju	0.239	4.14 <sup>k</sup>	10.47 <sup>k</sup>	0.95	0.395	v – Opitz (1996) Caribbean coral reefs.
23	Lg. Dem. NRA Ad.	0.481	0.9 <sup>c</sup>	5.29 <sup>i</sup>	0.95	0.170	
24	Lg. Dem. NRA Ju.	0.45	4.14 <sup>n</sup>	10.89 <sup>n</sup>	0.95	0.380	
25	Small Pelagics	1.824	2.845 <sup>c</sup>	11.677 <sup>i</sup>	0.95	0.310	
26	Medium Pelagics	0.3 <sup>c</sup>	2.5 <sup>n</sup>	8.5 <sup>i</sup>	0.891	0.294	
27	Large Pelagics Ad.	0.204	1.2 <sup>c</sup>	5.9 <sup>i</sup>	0.95	0.203	
28	Large Pelagics Ju.	0.302	3.35 <sup>c</sup>	10.81 <sup>i</sup>	0.95	0.310	
29	Marine Mammals	0.043 <sup>o</sup>	0.022 <sup>p</sup>	22.732 <sup>q</sup>	0	0.003	
30	Seabirds	0.015 <sup>r</sup>	0.04 <sup>s</sup>	78.68 <sup>t</sup>	0.285	0.001	
31	Sea turtles	0.001 <sup>m</sup>	0.15 <sup>r</sup>	3.5 <sup>r</sup>	0.114	0.043	
32	Coral	0.004	1.45 <sup>u</sup>	4.48 <sup>u</sup>	0.95	0.324	
33	Detritus	200 <sup>m</sup>	-	-	0.489	-	

janidae), yellow croakers and giant croakers (Sciaenidae) etc. were traditionally targeted by the fisheries, but are heavily depleted nowadays.

Catches became dominated by the substantial amount of juveniles and small pelagic species, which support the demand for trash fish feed for local mariculture (Wilson, 1996; Sadovy, 1998). In general, fishery resources in Hong Kong waters are heavily over-exploited. A combination of growth, recruitment, ecological and economic overfishing occurs in Hong Kong waters (Cook *et al.*, 1997; Pitcher *et al.*, 1998; Sadovy, 1998; Wilson, 1997).

### Ecopath model of the Hong Kong waters ecosystem in the 1990s

An Ecopath model for the Hong Kong marine

ecosystem in 1990s (Table 1) was used in this study<sup>1</sup> (Bucharly *et al.*, in prep.). The model comprised 33 functional groups, which included over 250 species from the Hong Kong survey database. Fish groups, prawns, cephalopods and benthic crustacean were divided into reef and non-reef associated (for details see Pitcher *et al.*, 1999). The fish groups were further divided into living bottom structure associated fish, small, medium, and large reef/non reef -associated fish and pelagic fish, where the size category was determined by asymptotic length. Parameters, including growth, mortality, consumption and diet data, were assembled from Hong Kong survey data (AFD, unpublished data), meta-analyses (e.g. Palomares and Pauly 1998; Pauly *et al.*, 1993) and databases for the South China Sea such as Fishbase (Froese and Pauly, 1998). Parameter

<sup>1</sup> This model will be revised to include two more functional groups and parameters from the study area.

**Table 2.** Value weight settings for the four management strategies.

Value component	Value weight			'Big compromise'
	Economic strategy	Ecological strategy	Social strategy	
Economic	1	0	0	1
Social	0	0	1	1
Ecological	0	1	0	1

values for functional groups were obtained from the weighted average of biomass of the species. The living bottom structure fish, large reef fish, non-reef fish and large pelagic fish were split into juveniles and adults (Walters *et al.*, 1997).

Seven sectors of the Hong Kong fishery were modelled: stern, hang, pair and shrimp trawlers, purse seiners, and two small-scale artisanal sectors 'P4/7' vessels and miscellaneous, which employed a mix of nets, traps and hook gear. Catch composition and landing value of each sector were obtained from the Hong Kong survey databases, while the cost profile was obtained from AFCD (pers. comm.).

The vulnerability parameter, which is an input to control bottom-up or top-down trophic control of the ecosystem, was difficult to estimate, especially without time series biomass data for the functional groups. A consensus from the meeting was that vulnerability factors calculated as linearly proportional to the trophic level of the functional groups were realistic. Vulnerability factors in this study were calculated using this method (Table 3).

### Methodology

Alternative fishery management policies under different policy objectives/strategies were explored using a newly developed routine named the 'policy optimisation interface' in the EwE software. Our Ecopath model of the 1990s Hong Kong waters ecosystem was used as the base model for the policy simulation. Four strategies that aimed at maximizing one or more management objectives were investigated. These included: (1) economic strategy; (2) ecological strategy; (3) social strategy; and (4) 'the big compromise'. The

details of the parameters setting of each strategy were shown in Table 2. In the model, the 'policy simulator' will search for a policy, which maximizes the total objective function i.e. the weighted sum of the objectives of the economic, social and ecological components according to the value weight specified (*but see Cochran, this volume*). For the social setting, since exact socio-economic data for the Hong Kong fisheries were not available, it was assumed that the smaller-scale fisheries, i.e. the P4/7 and miscellaneous types of fisheries, employed more people per catch. Therefore, the jobs/catch of P4/7 boats was arbitrarily set to 5 while the less cost-effective miscellaneous boats was set to be 2. The others remained as 1 job/catch.

For the ecological setting, it was aimed to maximize the biomasses of the large predatory species i.e. elasmobranch, LBS-assoc. fish adult, large demersal reef/non-reef associated fish adult, large pelagics (which are high-valued), and the charismatic groups i.e. marine mammals, turtles, seabirds and coral (their abundance is considered desirable in general by the Hong Kong public).

**Table 3.** Ecological settings for the policy optimisation interface.

Biomass group	B ideal/ B base	Importance		Vulnerability
		General	1/ (P/B)	TL gradient
Benthic Producers	1	0	0.084	0.2
Phytoplanktons	1	0	0.004	0.2
Zooplanktons	1	0	0.031	0.22
Jellyfish	1	0	0.2	0.43
Living Bottom Structure (LBS)	1	0	10	0.241
Small Zoobenthos	1	0	0.152	0.241
Macrozoobenthos	1	0	0.313	0.283
Benthic Crustacean NRA	1	0	0.177	0.304
Bent. Crustacean RA	1	0	0.541	0.43
Penaeid prawns NRA	1	0	0.167	0.367
Penaeid prawns RA	1	0	0.132	0.325
Elasmobranch	5	1	2	0.619
Cephalopods NRA	1	0	0.323	0.556
Cephalopods RA	1	0	0.323	0.556
LBS-assoc. fish Ad.	10	1	0.833	0.556
LBS-assoc. fish Juv.	1	0	0.242	0.409
Small Demersal fish RA	1	0	0.238	0.43
Small Demersal fish NRA	1	0	0.238	0.451
Medium Demersal fish RA	1	0	0.5	0.514
Medium Demersal fish NRA	1	0	0.5	0.535
Large Demersal fish RA. Ad.	10	1	1.111	0.577
Large Demersal fish RA. Juv.	1	0	0.242	0.409
Large Demersal fish NRA. Ad.	10	1	1.111	0.577
Large Demersal fish NRA. Juv.	1	0	0.242	0.451
Small Pelagic fish	1	0	0.299	0.451
Medium Pelagic fish	1	0	0.4	0.577
Large Pelagic fish Ad.	10	1	0.833	0.661
Large Pelagic fish Juv.	1	0	0.299	0.472
Marine Mammals	2	1	22.222	0.703
Seabirds	2	1	25	0.64
Turtles	2	1	6.667	0.241
Corals	5	1	0.69	0.2

**Table 4.** The value weight settings for sensitivity test between different weight value in the ecological stability component. For the the ‘big compromise’ and the ‘economical versus ecological’ strategies, simulations were run with ecological stabilities listed.

Value component	Value weight	
	The ‘big compromise’	Economical versus Ecological
Economic	1	1
Social	1	0
Ecological	1, 2, 3, 4	0.1, 1, 2, 4, 6, 8, 10, 12

Therefore, these groups were given higher values of B ideal/B base ratio and their importance was set as 1, while the others were set as 0. The B ideal/B base ratio was defined as the ratio of the user’s desired biomass to the biomass of that particular functional group in the Ecopath base model. The ecological objective function was calculated from the B ideal/B base ratio, which was weighted according to the importance set.

However, the relative ecological importance of particular functional groups in the model was highly subjective to the user. Therefore, the suggestion was made during the workshop that simulations should also be carried out under an importance setting which was equal to the reciprocal of the production/biomass ratio (P/B) in the base Ecopath model. It was generally a consensus at the workshop that low growth-rate, long-lived groups (low P/B ratio) are more vulnerable to exploitation. Therefore the use of the reciprocal of P/B as the importance setting provided an objective way to value ecological importance in the ecosystem during policy optimization. This approach was adopted in our study.

Simulations of a 30-year period were used to search for optimum fishing effort of the seven different fishery sectors under different management. The resulting economical, social, and ecological objective functions, and fishing efforts were recorded. Simulations were repeated for different starting fishing effort i.e. (1) Ecopath base F’s; (2) current F’s; and (3) random F’s, to ensure that a global optimum was obtained (F’s are the fishing efforts of the seven fishery sectors). In addition, the trophic level of fishery catch (TLC) which resulted from the suggested fishing effort in each strategy was calculated using:

$$TLC = [1/(C_i)] * \sum (C_i * TL_i),$$

Where,  $\sum C_i = C_t$ ,  $C_t$  is the total catch, while  $C_i$  is the catch by species  $i$ .

### Sensitivity test

Sensitivity of the policy simulations to different vulnerability settings was tested by repeating simulations under the four strategies with vulnerabilities of 0.2, 0.4, 0.6, and a gradient of vulnerabilities ranging from 0.2 to 0.7 which were directly proportional to the trophic level of each functional group (Table 3).

Moreover, sensitivity of the relative effect of the ecological stability on the economical and social performance was tested by running policy simulations under the settings in Table 4.

## Results

### Economic strategy

Results from the policy simulation that aimed to maximize economic benefit from vulnerability settings of 0.4 and 0.6 generally suggest that fishing effort exerted by stern trawler (ST) should be increased by 0.5 to 1 times the Ecopath base value, while the other fishing sectors should be reduced or increased slightly (Figure 2).

However, for a vulnerability setting of 0.2, the result suggested effort increases in purse seine (PS) and small outboard engine boat (P4/7), with effort decreased for stern trawlers and other fishing sectors. The results from vulnerabilities proportional to the trophic level of the functional groups is similar to the results from vulnerability settings of 0.4 and 0.6, except that it suggested a more than two-fold increase in the ‘miscellaneous’ sector.

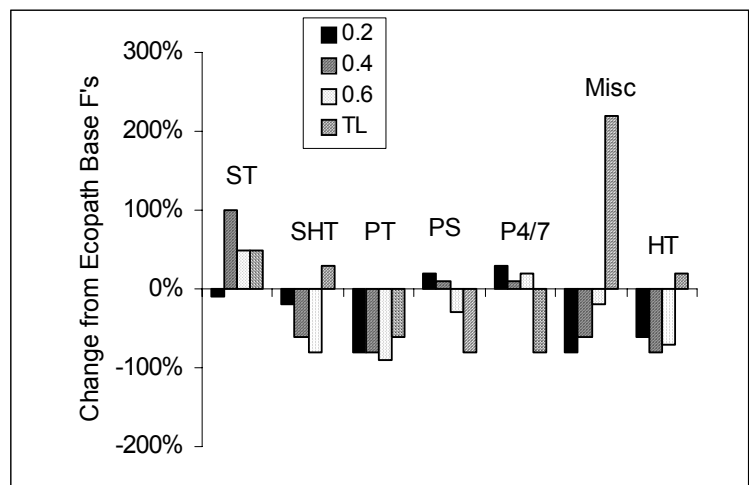

**Figure 2.** Suggested change of fishing effort for different fishing sectors in the economic strategy simulation.

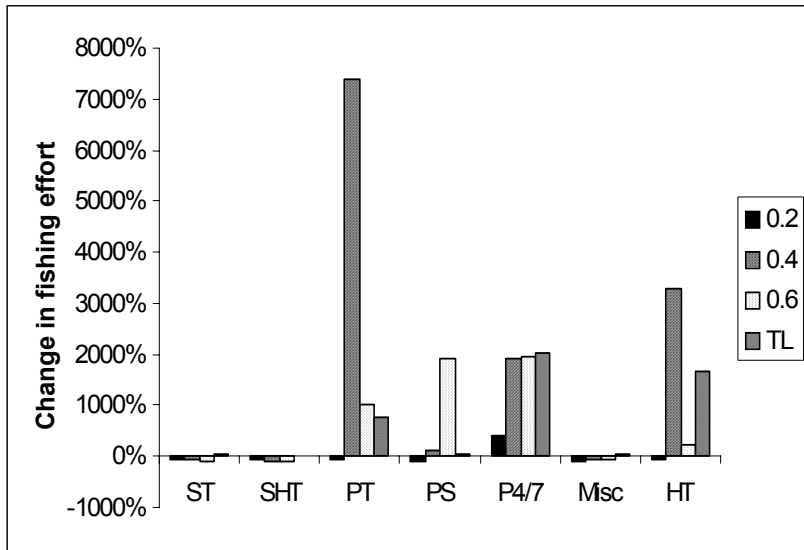

**Figure 3.** Suggested change of fishing effort for different fishing sectors in the social strategy simulation.

**Table 5.** Performance of the economical, social, and ecological objective functions for the four strategies.

Strategy	Strategy	Economic	Social	Ecological	Overall
Economic	1	2574.6	15550.5	-10458.3	0.23
Ecological	2	487.2	1257.3	-7672.6	-1.46
Social	3	-25250.7	57572.6	-12935.2	3.47
'Big Compromise'	4	1781.7	25020.2	-9966.7	-0.09

*Social strategy*

The policy simulation that aimed to maximize social strategy suggested increases in fishing effort of pair trawl, purse seine, hang trawl and P4/7 sectors to maximize social benefits (jobs/catch) (Figure 3). However the suggested results were sensitive to the vulnerability setting.

*Ecological stability strategy*

Results from the policy simulator suggested more than 50% decrease in effort for all fishing sectors to maximize ecological stability (as defined in the B ideal/B base and importance settings). These are consistent between simulated results from different vulnerability settings (figure 4).

*The 'big compromise'*

Results from policy simulator that aimed to maximize all the objective functions (economical, social and ecological) over all the vulnerability setting (0.2, 0.4, 0.6 and proportional to trophic level) generally suggested that the P4/7 fishing boats should be increased by 0.5 to 2-fold, while the oth-

ers should be decreased slightly. Results from simulations of this strategy were generally consistent between different vulnerabilities except that it suggested shrimp trawl effort should increase more than 2-fold at a vulnerability of 0.2, while the others decrease in effort. Moreover, the amount of suggested effort increase in the P4/7 sector was greater at a higher vulnerability setting.

When the vulnerability was set to be proportional to the trophic level of the functional group, and the reciprocal of the P/B ratio was used as ecological importance setting, the simulation results suggested higher increase in the P4/7 effort, and a general effort increase in other fishing sectors (Figure 5).

The economical, social, and ecological objective functions (performance) of the four strategies are summarized in Table 5.

Moreover, simulation with varying ecological value weight setting in different strategies showed that the economic and social performances correlated negatively with the increasing ecological stability setting (Figure 6). It was also found that the economic, social and ecological performance responded strongly with changing ecological stability setting when the ecological setting was increased from 0 to 2. When

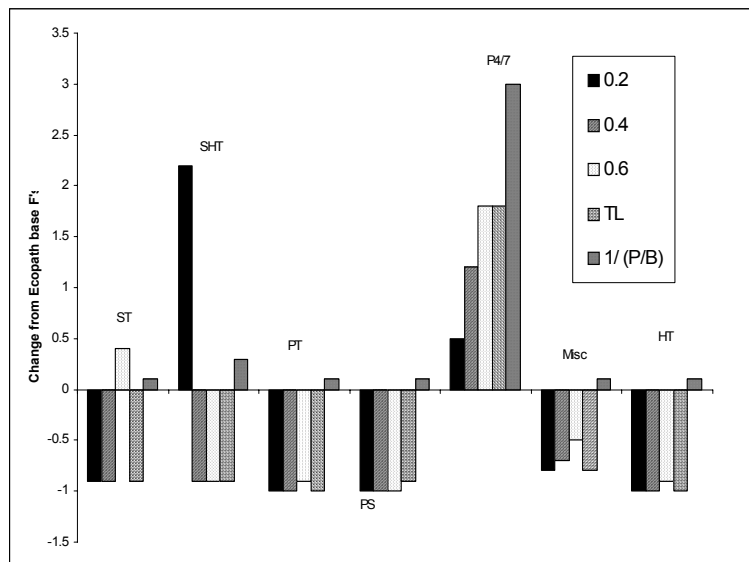

**Figure 4.** Suggested change of fishing effort for different fishing sectors in the ecological strategy simulation

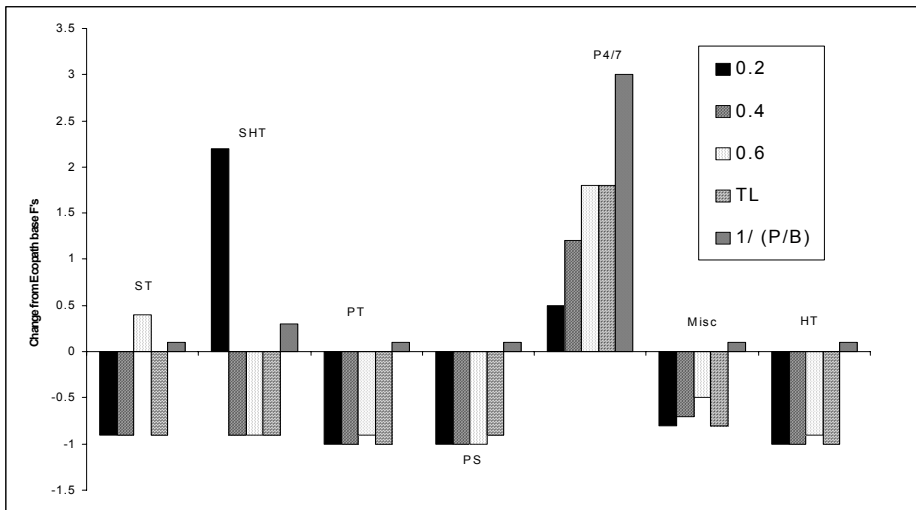

**Figure 5.** Suggested change of fishing effort for different fishing sectors for the ‘big compromise’ strategy at different vulnerability factor settings: 0.2, 0.4, 0.6, proportional to the trophic level (TL), and to the reciprocal of the production/biomass (P/B) ratio.

the ecological setting was increased to more than two, changes of the three performances were much weaker.

*Trophic level of catch*

The mean trophic level of catch calculated from the four strategies (with vulnerability setting proportional to trophic level of the functional group) showed that strategy maximizing ecological stability resulted in the highest mean trophic level while the strategy maximizing social benefits resulted in the lowest. Also, TLC lower than the base Ecopath value resulted from the economic strategy. The “big compromise” strategy produced an intermediate TLC among all strategies (Table 6).

**Discussion**

Our results were consistent with general observations of fisheries management. Simulation with objective policy that maximizes economic performance favours rapid turnover lower trophic level species, while a higher trophic level of fishery catch is achieved when ecological goals favour larger predators. Moreover, increase priority to

maximize ecological stability resulted in decreasing economic benefits. When the policy that maximizes jobs was prioritized, fisheries sectors that use more labour, typically small-scale mixed inshore fisheries were favoured. This is in parallel with the syndrome of Malthusian overfishing observed in developing countries (Pauly, 1997).

The optimization process for each management objective function involves restarting using different parameter values until no future improvement can be achieved. This proved to be much more difficult when higher values of vulnerability were assumed (>0.5), this likely results from a more complex response surface with many local optima. Automation of this process will assist users. Other optimization processes that can find the global optima could be employed.

**Table 6.** Mean trophic level of catch resulting from the suggested fishing effort from simulation of the four strategies.

Strategy	Trophic level of fishery catch
Base Ecopath model value	3.16
Economic only	3.14
Social only	2.45
Ecological only	3.40
The ‘big compromise’	3.21

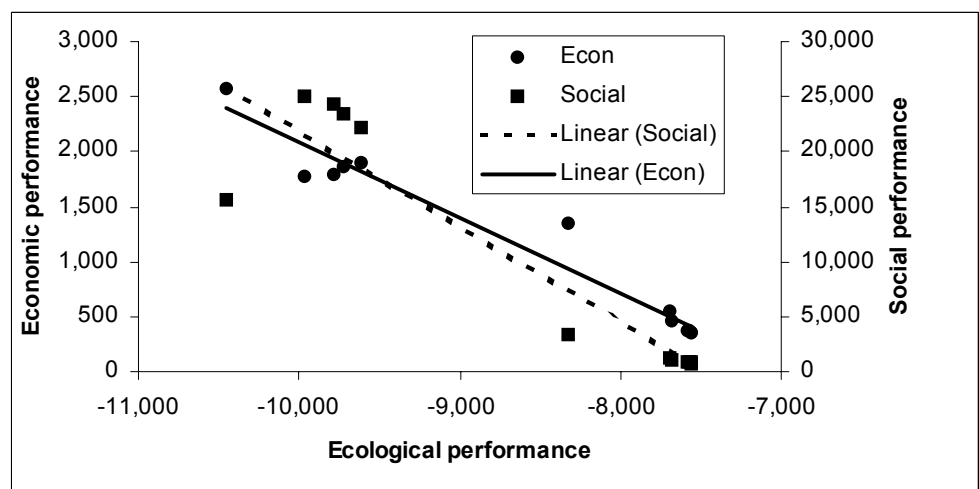

**Figure 6.** Plot of economic and social performance against ecological performance. The R-squares of the fitted line in the economic and social performance are 0.96 and 0.86 respectively.

Moreover, we noted instability of the ecosystem at higher values of vulnerability. Since the model employed in this study was preliminary, we believe that more stable ecosystem might result fine tuning the input parameters.

During this workshop, there were numerous revisions to the software. For consistency we used the version available at the end of the workshop (19<sup>th</sup> July 2000 version). The impact of later versions on our findings is unknown, however, from the changes seen to interim results during the workshop, we believe that they may be generally robust.

It was the consensus at the workshop that this approach shows real promise, and will gain credibility once the method is stable and well tested. It offers excellent insights into management trade-offs in an ecosystem context.

## References

- Agriculture and Fisheries Department 1996. Annual Report. Hong Kong Government.
- Alino, P. M., L. T. McManus, J. W. McManus, C. L. Nanola, M. D. Fortes, G. C. Trono, and G. S. Jacinto 1993. Initial parameter estimations of a coral reef flat ecosystem in Bolinao, Pangasinan, Northwestern Philippines. in V. Christensen and D. Pauly, editors. Trophic models of aquatic ecosystems. ICLARM Conf. Proc. 26.
- Arreguin-Sanchez, F., J. C. Seijo and E. Valero-Pacheco 1993. An application of ECOPATH II to the north continental shelf ecosystem of Yucatan, Mexico. in V. Christensen and D. Pauly (eds) Trophic models of aquatic ecosystems. ICLARM Conf. Proc. 26.
- Browder, J. A. 1993. A pilot model of the Gulf of Mexico continental shelf. in V. Christensen and D. Pauly, editors. Trophic models of aquatic ecosystems. ICLARM Conf. Proc. 26.
- Buchary, E. A. 1999. Evaluating the effect of the 1980 trawl ban in the Java Sea, Indonesia: an ecosystem-based approach. M.Sc. University of British Columbia, Vancouver, Canada.
- Cheung, K. 1965. Production and use of ice - Hong Kong. Pages 97-102 in Indo-Pacific fisheries council.
- Cook, D. C., A. L. K. Chan, K. C. C. Fok, and K. D. P. Wilson. 1997. A fisheries resource profile prior to artificial reef deployment in Hong Kong. in PACON 97 symposium on resource development - environmental issues and the sustainable development of coastal waters, Hong Kong.
- Dalsgaard, A. J. T. 1999. Modeling the Trophic Transfer of Beta Radioactivity in the Marine Food Web of Enewetak Atoll, Micronesia. M.Sc. Thesis. University of British Columbia, Vancouver.
- EVS 1996. Contaminated Mud Disposal at East Sha Chau: Comparative Integrated Risk Assessment. Prepared for Hong Kong Government, Civil Engineering Department.
- Froese, R. and D. Pauly 1998. FishBase 98: Concepts Design and Data Sources. ICLARM, Manila.
- Greze, V. N., and O. Kinne 1978. Production of animal population. in O. Kinne, editor. Marine Ecology: a Comprehensive, Integrated Treatise on Life in Oceans and Coastal Waters. Vol. 4. Dynamics. John Wiley & Sons, New York.
- Hoyo, J. D., A. Elliott, J. Sargatal, and N. J. Collar 1992. Handbook of the birds of the world. International Council for Bird Preservation. Lynx Edicions, Barcelona.
- Jarre-Teichmann, A., and D. Pauly 1993. Seasonal changes in the Peruvian upwelling ecosystem. in V. Christensen and D. Pauly, editors. Trophic models of aquatic ecosystems. ICLARM Conf. Proc. 26.
- Morton, B. S. 1994. Hong Kong's coral communities: status, threats and management plans. Marine Pollution Bulletin 29:74-83.
- Morton, B., and J. Morton 1993. The Sea Shore Ecology of Hong Kong. Hong Kong University Press, Hong Kong.
- Ni, I. H., and K. Y. Kwok 1999. Marine fish fauna in Hong Kong waters. Zoological Studies 38:130-152.
- Opitz, S. 1998. A quantitative model of the trophic interactions in a Caribbean coral reef ecosystem. Pages 259-268 in V. Christensen and D. Pauly, editors. Trophic models of aquatic ecosystems. ICLARM Conf. Proc. 26.
- Palomares, M. L. D., and D. Pauly 1998. Predicting food consumption of fish populations as functions of mortality, food type, morphometrics, temperature and salinity. Mar. Freshwater. Res. 49:447-453.
- Pauly, D. 1997. Small-scale fisheries in the tropics: marginality, marginalization, and some implications for fisheries management. Pages 1-9 in E. K. Pikitch, D. D. Huppert, and M. P. Sissenwine, editors. Global trends: fisheries management.
- Pauly, D., M. L. Soriano-Bartz, and M. L. D. Palomares 1993. Improved construction, parametrization and interpretation of steady-state ecosystem models. Pages 1-13 in V. Christensen and D. Pauly (eds) Trophic models of aquatic ecosystem. ICLARM Conf. Proc. 26.
- Pauly, D., and V. Christensen 1995. Stratified models of large marine ecosystems: a general approach and an application to the South China Sea :148-174.
- Pauly, D., V. Christensen and V.J. Sambilya 1990. Some features of fish food consumption estimates used by ecosystem modellers. ICES CM 1990/G 17:8pp.
- Pitcher, T. J., R. Watson, A. Courtney, and D. Pauly 1998. Assessment of Hong Kong's inshore fishery resources. Fisheries Centre Research Reports 6(1): 155pp.
- Pitcher, T.J., Watson, R., Haggan, N., Guénette, S., Kennish, R., Sumaila, R., Cook, D., Wilson, K. and Leung, A. (2000) Marine Reserves and the Restoration of Fisheries and Marine Ecosystems in the South China Sea. Bulletin of Marine Science 66(3): 530-566.
- Polovina, J. J. 1984. Model of a coral reef ecosystem I. The ECOPATH model and its application to French Frigate Shoals. Coral Reefs 3:1-11.

- Reilly, S. B., and J. Barlow 1986. Rates of increase in dolphin population size. *Fishery Bulletin* 84:527-533.
- Sadovy, Y. 1998. Patterns of reproduction in marine fishes of Hong Kong and adjacent waters. Pages 261-273 in B. Morton, editor. *The Third International Conference on the Marine Biology of the South China Sea, Hong Kong*. Hong Kong University Press, Hong Kong.
- Sadovy, Y. J., and A. S. Cornish 2000. Reef fishes of Hong Kong. Hong Kong University Press, Hong Kong.
- Silvestre, G., S. Selvanathan, and A. H. M. Salleh 1993. Preliminary trophic model of the coastal fisheries resources of Brunei Darussalam, South China Sea. Pages 300-306 in V. Christensen and D. Pauly, editors. *Trophic models of aquatic ecosystems*. ICLARM Conf. Proc. 26.
- Stather, K. 1975. The evolution of fishing craft in Hong Kong - 1947 to 1971. *Hong Kong fisheries bulletin* 2:1-9.
- Trites, A. W., and D. Pauly 1998. Estimating mean body masses of marine mammals from maximum body lengths. *Can. J. Zool.* 76: 886-896.
- Trites, A., and K. Heise. 1996. Marine Mammals. In D. Pauly and V. Christensen (eds) *Mass-balance models of Northeastern Pacific ecosystem*. Fisheries Centre Research Reports 4(1): 131 pp.
- Trites, A. W., V. Christensen, and D. Pauly 1997. Competition between fisheries and marine mammals for prey and primary production in the Pacific Ocean. *J. Northw. Atl. Fish. Sci.* 22:173-187.
- Wilson, K. D. P. 1997. The Hong Kong marine fish culture industry - challenges for sustainable development. *Proceedings of the first international symposium on marine conservation Hong Kong* 1:86-97.
- Walters, C., V. Christensen, and D. Pauly 1997. Structuring dynamic models of exploited ecosystem from trophic mass-balance assessment. *Reviews in Fish Biology and Fisheries* 7:139-172.
-



## Exploration of Management and Conservation Strategies for the Multispecies Fisheries of Lake Malawi using an Ecosystem Modelling Approach

Edward Nsiku

Fisheries Centre, UBC<sup>2</sup>

### Abstract

Lake Malawi, one the African Great Lakes, is the most species-rich freshwater body in the world. Conservation of the lake is thus one of the important areas that needs to be focused by the riparian countries bordering it as well as the scientific community and international funding agencies. The lake's ecosystem and fish resources, which are some of the important factors in the implementation of conservation initiatives, are analyzed through construction of an Ecopath model. Application of Ecosim routine follows in order to optimize policy, particularly of fisheries, in the objectives of maximizing fisheries rent, social benefits, rebuilding of mandated species and ecosystem structure or health. Trophic interrelationships in the functional groups, which include the main fish species caught, and trophic structure of the lake are assessed. Twenty-six functional groups are quantified. *Chaoborus edulis*, *Engraulicypris sardella* larvae and the predatory zooplankton, *Mesocyclops aequatorialis aequatorialis*, form the main pathway through which energy flows from bottom to top trophic levels in the Lake Malawi ecosystem. The trophic structure of the lake system deteriorates over time. Maturity of the lake ecosystem is in the middle stages. Standing biomass and production rates, i.e. model control regimes, are dependent more on food availability rather than impact of predation. The model supports observations of overexploitation in most fish resources that form the main fisheries in Lake Malawi. This includes even offshore species, especially those that are also exploited by traditional fishers such as kampango. The traditional fisheries sector contributes more than the commercial sector to the influence fisheries has on the ecosystem of the lake. The analysis optimizes the exploitation and conservation goals for the ecosystem and fish resources of Lake Malawi at reduced fishing effort and catch from the current levels.

### Introduction

Lake Malawi is the third largest and second deepest freshwater body in Africa. It is found at the southern tip of the East African Rift Valley. Its riparian countries are Malawi, Mozambique and Tanzania. The lake has a total surface area of 28800 km<sup>2</sup> and an average depth of 292 m, with a

maximum point of about 700 m. It also contains 7 % of the world's total surface fresh water (Patterson and Kachinjika 1995). Lake Malawi is among lakes with the most abundant fish species in the world (Barel *et al.* 1985; Ribbink 1991; Pitcher 1994). However, clear waters of low biological productivity characterize a large part of the lake (ICLARM/GTZ 1991). The southern part is shallow and produces a lot of fish food and forms a rich-fishing area.

There is an annual cycle of stratification during which epi-, meta- and hypo-limnion zones are marked from December to March. Mixing occurs from May to August. Depth, temperature and water currents cause these events. The first layer extends from surface of the lake to 125 m in depth. The middle layer can be as deep as 230m. Beyond this is a third layer, which is permanently stratified and anoxic so that no mixing ever takes place. The effect of temperature in the water column is marked, with the presence of a sudden transition depth range, the thermocline, between 40 and 60m in January, and extending to 100m by May. The thermocline disappears during the cold 'mwera' season. Wind causes strong currents so that interchange of conditions and other properties in the two upper layers, occur. Complete nutrient mixing, therefore takes place only in the two zones. The euphotic zone, i.e. that part of the water column in which photosynthesis occurs, extends to 70m. This is not affected by mixing in the upper two zones. Temperature drops as depth increases from the lake surface. As a result, the depth or temperature dependent chemical elements including nutrients also vary (Beadle 1974; Eccles 1978; FAO 1993; Patterson and Kachinjika 1995; Patterson *et al.* 1995). Mixing of nutrient-rich deep waters and nutrient poor surface waters is vital for sustenance of the fisheries in the lake (Arnell *et al.* 1996; WWF 1999).

The aim of this paper is to identify optimal policies for exploiting and conserving the fish resources and ecosystem of Lake Malawi. The optimization is based on the basic estimates of an ecosystem model of the lake between 1976 and 1996 (Nsiku 1999). The focus is, however, on ecosystem simulation (Walters *et al.* 1997; Christensen *et al.* 2000). The fisheries are optimized in relation to the management goals of maximizing rent, social benefits, rebuilding of mandated species, ecosystem structure and balancing all the goals.

The analysis focuses on traditional and commercial fisheries sectors. These are the main sectors in the lake's fisheries apart from a minor contribution, in terms of catch amount, of the aquarium

<sup>2</sup> Current address: 109-7341 19<sup>th</sup> Avenue, Burnaby BC, Canada V3N 1E3; E-mail: emnsiku@aol.com.

**Table 1.** Diet Composition for the Lake Malawi Ecopath model functional groups: 1977-1996 (values are rounded to two decimal places).

Prey\Predator	Nkunga	Kampango	Matemba	Utaka	Ndunduma	Kambuzi	Chisawasawa	Chambo	Chitunguni	Mbuna	Mcheni	Bombe	Mlamba	Usipa	Usipa larvae	Sanjika	Mpasa	Nchila	Nkholokolo	Samwamowa	Nkhungu	Nkhono	Top pred	Zooplankton	
Nkunga																								0.01	
Kampango		0.01																							
Matemba																									0.05
Utaka	0.01	0.01	0.01									0.01	0.01							0.01					
Ndunduma		0.09	0.01							0.01	0.01	0.12								0.01					0.10
Kambuzi	0.02	0.06	0.01										0.01							0.01					
Chisawasawa			0.01									0.01	0.01							0.01					
Chambo		0.01	0.01																						
Chitunguni		0.01	0.01											0.01											
Mbuna	0.16	0.3	0.07									0.30	0.15							0.05					0.20
Mcheni		0.02																							
Bombe												0.01													0.05
Mlamba													0.01	0.01						0.05					
Usipa	0.05	0.25	0.01							0.28						0.20	0.20								
Usipa larvae			0.01	0.04	0.10				0.05	0.52	0.05				0.38	0.38									
Sanjika																									
Mpasa																									
Nchila																									
Nkholokolo																									0.02
Samwamowa																				0.01					0.01
Nkhungu			0.09	0.22	0.45		0.05		0.07	0.09	0.05	0.03	0.12		0.3	0.3		0.59	0.02						
Nkhono	0.09		0.06	0.02		0.09	0.10		0.01				0.05					0.01	0.15	0.01					0.18
Top predators																									0.10
Zooplankton			0.18	0.20	0.09	0.11	0.12	0.09	0.02	0.20	0.05	0.09	0.02	0.5	0.53	0.1	0.09	0.01	0.12	0.15	0.53				0.01
Phytoplankton			0.36	0.48	0.17	0.71	0.67	0.90	0.90	0.47	0.04		0.25	0.15	0.45			0.51	0.08	0.27	0.47	0.15			0.90
Detritus			0.01	0.02		0.05	0.01	0.01	0.08	0.05	0.02		0.30					0.17	0.01	0.15		0.20			
Import	0.67	0.24	0.15	0.02	0.20	0.05	0.05	0.01		0.15		0.46	0.02	0.23	0.02	0.02	0.03	0.30	0.05	0.25	0.01	0.65	0.28	0.09	
Sum	1.00	1.00	1.00	1.00	1.00	1.00	1.00	1.00	1.00	1.00	1.00	1.00	1.00	1.00	1.00	1.00	1.00	1.00	1.00	1.00	1.00	1.00	1.00	1.00	1.00

or ornamental fisheries sector. The traditional fisheries sector is, however, the most important with respect to management concerns.

**Methods**

The trophic structure of the Lake Malawi ecosystem between 1977 and 1996 is constructed using Ecopath (Christensen and Pauly 1992) and ecosystem simulation is run for a period of twenty years using Ecosim (Walters *et al.* 1997; Christensen *et al.* 2000). A mixed control regime is used in the simulation.

The Ecopath input data are from research studies on Lake Malawi. Four studies contribute most of the data. They are the FAO programme between 1977 and 1981; Malawi Government, UNDP and FAO joint study from 1988 to 1992; ODA-UK/SADC project between 1990 and 1994; and ICEIDA research programme from June 1994 to March 1996 (Degnbol 1993; FAO 1993; Menz 1995; Banda and Tomasson 1997). Many other sources are also used. However, data for some of the trophic boxes are estimated in the model.

Diet compositions (Table 1) are from Nsiku (1999). In the present analysis the diets are edited a little for the lower groups.

The model is set to represent the whole lake as one ecosystem. It has twenty-six functional groups (Table 2). There are nineteen fish groups and single trophic boxes for usipa larvae, phytoplankton, molluscs, apex predators (fish eating avian, reptiles and mammals), zooplankton (herbivorous and other species), detritus and lakefly.

The model groups, especially those for fish, are identified by their Malawian vernacular names reflective of indigenous technical knowledge (Berlin 1992), particularly of the fishing community's perception of similarities in the fish resources. The grouping is also guided by the system definition, i.e., a functional group may be of ecologically or taxonomically related species, single species, or size/age items (Christensen and Pauly 1992).

A strategy of varying fishing efforts over a twenty-year period at equilibrium biomass is first considered. Vulnerability is set at 0.25. Secondly, the ef-

**Table 2.** Summary of the Lake Malawi ecosystem model functional groups.

#	Local Name	Details <sup>1</sup>
1	Nkunga	Eel <i>Anguilla nebulosa</i> and mastacembelids <i>Mastacembelus shiranus</i> and <i>M. sp.</i> 'Rosette'
2	Kampango	Bagrid catfish <i>Bagrus meridionalis</i> .
3	Matemba	Represents barbel cyprinids, one alestiid, two cyprinodontids and one anabantid.
4	Utaka	Bottom feeding cichlids in genera <i>Copadichromis</i> , <i>Cyrtocara</i> , <i>Maravichromis</i> and <i>Nyasachromis</i> .
5	Ndunduma	Demersal and off-shore cichlids belonging to genera <i>Diplotaxodon</i> , <i>Palladichromis</i> and <i>Placidochromis</i> .
6	Kambuzi	Cichlids in genera <i>Protomelas</i> , <i>Hemitaeniochromis</i> , <i>Dimidiochromis</i> , and <i>Taeniochromis</i>
7	Chisawasawa	Mostly bottom feeding cichlids in genera <i>Lethrinops</i> , <i>Taeniolethrinops</i> and <i>Tramitichromis</i> .
8	Chambo	Refers to three species of pelagic tilapiine cichlids in the genus <i>Oreochromis</i> ; <i>O. squampinis</i> , <i>O. lidole</i> and <i>O. karongae</i> .
9	Chilunguni	Two cichlid species, <i>Tilapia rendalli</i> and <i>Oreochromis shiranus</i> are specified in this group.
10	Mbuna	Rock-dwelling cichlids popular with tropical fish aquarists and ornamental tropical fish trade. Most species belong to genus <i>Pseudotropheus</i> . There are thirteen other mbuna genera <sup>2</sup> .
11	Mcheni	Are offshore, pelagic and demersal occurring tigerfish cichlids in the genus <i>Ramphochromis</i> .
12	Bombe	Ten species of large clariid catfishes in the genus <i>Bathyclarias</i> .
13	Mlamba	Clariid catfishes in the genus <i>Clarias</i> . There are four species; <i>C. gariepinus</i> , <i>C. mellandi</i> , <i>C. mossambicus</i> and <i>C. theodora</i> .
14	Usipa	Refers to the cyprinid <i>Engraulicypris sardella</i> .
15	Usipa larvae	Larvae stage of <i>Engraulicypris sardella</i> .
16	Sanjika	Refers to bariliine cyprinid <i>Opsaridium microcephalus</i>
17	Mpasa	The bariliine cyprinid <i>Opsaridium microlepis</i> .
18	Nchila	Represents two cyprinids, <i>Labeo mesops</i> and <i>L. cylindricus</i> . Only <i>L. mesops</i> supports a fishery in the lake.
19	Nkholokolo	Refers to squeakers: two small mochokids <i>Synodontis njassae</i> and <i>Chiloglanis neumanni</i> . The main species, <i>S. njassae</i> , is endemic to the lake.
20	Samwamowa	Represents mormyrid species in the genera of <i>Marcusensis</i> , <i>Mormyrus</i> and <i>Petrocephalus</i> .
21	Nkhungu	The lakefly <i>Chaoborus edulis</i> forms a key link in energy flow in the lake ecosystem.
22	Nkhono	The group represents gastropod and lamellibranch molluscs.
23	Top predators	This group represents higher animals; fish-eating birds, reptiles (monitor lizards and crocodiles) and otters.
24	Zooplankton	The group has herbivorous and carnivorous zooplankton which include copepods ( <i>Mesocyclops aequatorialis aequatorialis</i> , <i>Tropodiaptomus canningtoni</i> , and <i>Thermocyclops neglectus</i> ), cladocerans ( <i>Diaphanosoma excisum</i> and <i>Bosmina longirostris</i> ), naupulii, <i>Diaptomus kraepelini</i> and <i>Mesocyclops leuckarti</i> .
25	Phytoplankton	This functional group includes species in the genera <i>Aulacoseira</i> , <i>Surirella</i> , <i>Stephanodiscus</i> , <i>Mougeotia</i> , <i>Cymatopleura</i> , <i>Closterium</i> , <i>Synedra</i> and <i>Staurastrum</i> .
26	Detritus	Represents organic matter, either dissolved or particulate.

1. A detailed list of fish species in Lake Malawi is found in Nsiku (1999).

2. They are *Cyathochromis*, *Cynotilapia*, *Docimodus*, *Electochromis*, *Exochromis*, *Fossorochromis*, *Genyochromis*, *Gephrochromis*, *Hemitalapia*, *Iodotropheus*, *Melanochromis*, *Nimbochromis*, and *Petrotilapia*. However, some of the mbuna genera are being revised (Snoeks 2000).

fect of different management goals on traditional and commercial fisheries sectors is analyzed. This part covers five management goals (Table 3). The traditional and commercial fisheries sectors are applied as fleets with jobs/catch value of 0.741 and 0.259 respectively. These are based on the total catches rather than values of the sectors in Table 4.

Input fleet costs used in the model fishery simulation are in Table 5. The mandated rebuilding focuses on seven species-based fisheries (Table 6). One modification is made for analysis of fisheries sector landings. The catch, which is based on the

traditional fisheries, is taken to represent total catch from Lake Malawi. Proportions of traditional and commercial fisheries to the total catch are based on Turner (1977), Tweddle and Magasa (1989), Pitcher (1994), Turner (1995, 1996), Banda *et al.* (1996), and Banda and Tomasson (1997) for the different species-based fisheries (Table 4).

## Results

Table 7 details the basic estimates of the model. The model is also graphically summarized in Figure 1. Many groups in lower trophic boxes utilize

**Table 3.** Specifications of the management goals utilized for the optimization of the fisheries in Lake Malawi at vulnerabilities (V) 0.2, 0.27<sup>a</sup>, 0.5 and 0.7.

Management goal	Symbol	Weights assigned to performance indicators			
		Net economic value	Social (employment) value	Mandated rebuilding	Ecosystem structure
Optimizing net economic value	MS1	1.0000	0.0001	0.0001	0.0001
Optimizing social (employment) value	MS2	0.0001	1.0000	0.0001	0.0001
Optimizing mandated rebuilding	MS3	0.0001	0.0001	1.0000	0.0001
Optimizing ecosystem structure	MS4	0.0001	0.0001	0.0001	1.0000
Optimizing all goals	MS5	1.0000	1.0000	1.0000	1.0000

detritus apart from phytoplankton. The ecotrophic efficiencies are in the range of 0.10 - 0.95 except for nkholokolo and detritus both of which have an EE value of 0.007. It is not clear whether this is only due to low predation exerted on the groups. Almost all the production over consumption ratio values or gross food conversion efficiencies (GE) fall in the expected range of 0.1 - 0.3 (Christensen and Pauly 1992).

Two exceptions are the values of nkholokolo and top predators at 0.059 and 0.435 respectively. Groups with GE values close to 0.3 include matemba, bombe, usipa and nkhungu. Among these functional groups only bombe has relatively large-sized species. With the exception of usipa larvae which has an R/B value of 458.0 year<sup>-1</sup>, the respiration over biomass ratios, which can be any positive value (Christensen and Pauly 1992), are in the normal range of 0-100 (Bundy 1998).

Overall, the value of production over consumption ratio is 0.0005. Therefore, Lake Malawi system has very low gross efficiency, i.e. limited

quantities of discrete trophic flows (Christensen and Pauly 1992; Dalsgaard 1999). The lake system fishery has a mean trophic level of 3.7. The biomass over total throughput is 0.008 year<sup>-1</sup> and omnivory index is 0.426. The production over respiration ratio (P/R) is at 2.95, less than the value of 5.88 given in Nsiku (1999).

In the mixed trophic impact (MTI) analysis of the Lake Malawi ecosystem, phytoplankton and, to a lesser extent detritus have greatest influence and are the basis of energy flow in the lake. Lower groups that have positive impact are nkhungu *Chaoborus edulis*, usipa larvae and zooplankton. The MTI and graph of model trophic structure support observations of Allison *et al.* (1995a) that lakefly, larvae of *E. sardella* and predatory zooplankton *Mesocyclops aequatorialis aequatorialis* are the main users of secondary production in the Lake Malawi ecosystem. Fish groups that contribute most to the lake system are usipa and mbuna.

**Table 4.** Catch contributions <sup>a</sup> of the traditional and commercial fleets derived from the 1976-96 mean catch of the traditional fisheries in Lake Malawi (values are based on prices of 1996; dash indicates insignificant amount; figures are rounded to two decimal places).

Fish Group	Fleet <sup>b</sup> Catch				Value			Price <sup>c</sup> (MWK/Kg)
	Total (t)	Traditional (t·km <sup>-2</sup> )	Commercial (t·km <sup>-2</sup> )	Total (MWK'10 <sup>6</sup> )	Traditional (MWK'10 <sup>6</sup> )	Commercial (MWK'10 <sup>6</sup> )		
Chambo	4398	0.15	0.10	0.06	62.63	39.85	22.77	14.24
Chilunguni	356	0.01	0.01	0.00	3.58	3.58	0.00	10.05
Kambuzi	2224	0.08	0.08	0.00	11.36	11.36	0.00	5.11
Utaka	10271	0.36	0.22	0.14	62.55	38.49	24.06	6.09
Chisawasawa	179	0.01	0.00	0.01	1.33	0.00	1.33	7.41
Kampango	2005	0.07	0.04	0.03	17.96	10.78	7.19	8.96
Mcheni	259	0.01	0.01	0.00	2.00	2.00	0.00	7.72
Mlamba	1533	0.05	0.04	0.01	12.75	9.57	3.19	8.32
Usipa	5858	0.20	0.16	0.04	41.71	33.37	8.34	7.12
Nchila	168	0.01	0.01	0.00	1.96	1.96	0.00	11.67
Mpasa	112	0.00	0.00	0.00	1.66	1.66	0.00	14.82
Sanjika	122	0.00	0.00	0.00	1.15	1.15	0.00	9.39
Nduduma	146	0.01	0.00	0.01	1.83	0.00	1.83	12.56
Bombe	1465	0.05	0.04	0.01	12.19	9.14	3.05	8.32
Nkholokolo	37	0.00	0.00	0.00	0.29	0.29	0.00	7.72
Mean	1942	0.07	0.05	0.02	15.66	10.88	4.78	9.30
Total	29133	1.01	0.71	0.30	234.95	163.19	71.76	139.50

Source for catch: MDF (1996). <sup>a</sup>The proportions of the catches in the sectors are scaled to equal 1 before the amounts are rounded off to two decimal places, i. e., fleet jobs/catch value of 0.741 for traditional and 0.259 for commercial fisheries; <sup>b</sup>Fleet in this analysis designates a fisheries sector comprising of many fishing units, sometimes of different fishing gears; <sup>c</sup>This is beach or landing price; rate of exchange for 1US\$ = 15.3 MWK in 1996 (IMF 1998).

**Table 5.** Some economic factors for Lake Malawi's traditional and commercial fisheries sectors.

Fishery	Fixed cost (%)	Effort related to cost (%)	Sailing related cost (%)	Profit (%)	Total value (%)
Traditional	0.00	21.20	1.00	77.80	100
Commercial	30.90	21.40	25.60	22.10	100
Mean	15.45	21.30	13.30	49.95	100

Data sources used for estimates: ICLARM/GTZ 1991; GOM/UN 1992; GOM 1997.

A limited positive impact is from ndunduma and utaka with much less contribution from chambo and kambuzi. With the exception of bombe, tertiary consumers with trophic levels of 3.4 and above which also include nkunga, kampango, sanjika, mpasa, mcheni and top predators do not have any positive impact in the lake (Figure 2a). Each group's contribution to the lake system is indicated by its sum of the mixed trophic impacts (Figure 2b). Apart from nchila and matemba, which have neither positive nor negative total impacting effect but are marginally impacted by the lake system, both chambo's impacted and impacting total values are the least. Nkhono is the only group with negative total values in its impacted and impacting effect.

Figure 3 summarizes the effect of changing fishing effort on equilibrium biomass for the Lake Malawi ecosystem. Simulation of fisheries of the lake as a whole is achieved by running the combined fleet option. Vulnerabilities that result in smooth model runs for the equilibrium biomass analysis are between 0.10 and 0.29. A fishing rate of 1.0 does not vary biomass in the functional groups. Biomass decreases in almost all fish groups that support fishing operations as fishing rate rises. The groups most affected are chambo, mpasa, kampango, utaka, sanjika, nchila and

**Table 6.** Ratios of the fishery groups focused upon for the mandated rebuilding management goal; values for the analysis are specified for mandated relative biomass and are default for structure relative weight.

No.	Group	Mandated Relative Biomass	Structure Relative Weight
1	Kampango	1.0	1.2
2	Utaka	1.0	2.0
3	Kambuzi	1.0	2.0
4	Chambo	1.0	2.0
5	Sanjika	1.0	1.6
6	Mpasa	1.0	1.6
7	Nchila	1.0	0.2

**Table 7.** Basic estimate parameters for the Lake Malawi ecosystem between 1977 and 1996 (estimated Ecopath model parameters are in italics/light shading. Dashes mean that data cannot be assigned or is not available; most values are rounded to two decimal places). Data sources are given in Nsiku (1999).

Number	Group Name	Trophic level	Biomass (t·km <sup>-2</sup> )	Production over biomass (year <sup>-1</sup> )	Consumption over biomass (year <sup>-1</sup> )	Ecotrophic efficiency	Production over consumption	Catch (t·km <sup>-2</sup> ·year <sup>-1</sup> )	Flow to detritus (t·km <sup>-2</sup> ·year <sup>-1</sup> )	Net efficiency	Omnivory index	Respiration (t·km <sup>-2</sup> ·year <sup>-1</sup> )	Assimilation (t·km <sup>-2</sup> ·year <sup>-1</sup> )	Production over respiration	Respiration over biomass (year <sup>-1</sup> )
1	Nkunga	3.4	0.00	0.80	4.00	0.94	0.20	-	0.00	0.25	0.99	0.00	0.00	0.33	2.40
2	Kampango	3.7	0.28	0.90	5.45	0.34	0.17	0.07	0.47	0.21	0.45	0.97	1.22	0.26	3.46
3	Matemba	2.7	0.00	4.60	11.05	0.87	0.30	-	0.00	20.52	0.68	0.00	0.01	1.09	4.24
4	Utaka	2.6	1.98	0.50	5.67	0.48	0.09	0.36	2.77	0.11	0.49	8.01	9.00	0.12	4.04
5	Ndunduma	3.2	2.49	0.50	5.87	0.76	0.09	0.01	3.23	0.11	0.48	10.45	11.69	0.12	4.20
6	Kambuzi	2.2	0.49	0.50	3.90	0.95	0.13	0.08	0.39	0.16	0.19	1.27	1.52	0.19	2.62
7	Chisawasawa	2.3	0.31	0.50	5.06	0.67	0.10	0.01	0.37	0.12	0.29	1.11	1.27	0.14	3.55
8	Chambo	2.1	0.57	0.50	5.06	0.81	0.10	0.15	0.63	0.12	0.07	2.02	2.30	0.14	3.55
9	Chilunguni	2.0	0.27	0.50	4.48	0.67	0.11	0.01	0.28	0.14	0.01	0.08	0.96	0.16	3.08
10	Mbuna	2.5	7.47	0.50	5.06	0.67	0.10	-	8.79	0.12	0.45	26.49	30.23	0.14	3.55
11	Mcheni	3.5	0.29	0.50	5.39	0.28	0.09	0.01	0.41	0.12	0.17	1.09	1.23	0.13	3.81
12	Bombe	3.4	1.11	0.90	3.31	0.09	0.27	0.05	1.64	0.34	0.78	1.94	2.94	0.52	1.75
13	Mlamba	2.7	1.16	0.90	5.33	0.15	0.17	0.05	2.13	0.21	0.78	3.91	4.96	0.27	3.36
14	Usipa	2.9	0.56	2.50	9.23	0.76	0.27	0.20	1.36	0.34	0.31	2.73	4.13	0.51	4.88
15	Usipa larvae	2.5	0.13	62.00	650.00	0.61	0.10	-	20.07	0.12	0.22	59.54	67.60	0.14	458.00
16	Sanjika	3.6	0.03	0.60	6.21	0.22	0.10	0.00	0.05	0.12	0.07	0.13	0.15	0.14	4.37
17	Mpasa	3.6	0.02	0.60	4.23	0.33	0.14	0.00	0.03	0.18	0.07	0.06	0.07	0.22	2.78
18	Nchila	2.0	0.01	4.00	40.00	0.15	0.10	0.01	0.11	0.13	0.09	0.28	0.32	0.14	28.00
19	Nkholokolo	3.2	0.59	0.50	8.50	0.01	0.06	0.00	1.30	0.07	0.24	3.72	4.01	0.08	6.30
20	Samwamowa	2.6	0.00	1.95	11.62	0.36	0.17	-	0.00	0.21	0.70	0.01	0.01	0.27	7.35
21	Nkhungu	2.5	1.75	19.40	69.70	0.47	0.28	-	42.39	0.35	0.21	63.62	97.58	0.53	36.36
22	Nkhono	2.0	5.00	0.42	5.60	0.95	0.08	-	5.71	0.09	0.15	20.29	22.40	0.10	4.06
23	Top predators	3.6	0.00	25.22	58.00	0.23	0.44	-	0.03	0.54	0.73	0.02	0.05	1.19	21.18
24	Zooplankton	2.0	5.38	30.50	144.57	0.93	0.21	-	167.79	0.26	0.03	458.14	622.23	0.36	85.16
25	Phytoplankton	1.0	7.62	258.40	-	0.36	-	-	1257.14	-	0.00	0.00	-	-	-
26	Detritus	1.0	-	-	-	0.01	-	-	0.00	-	0.25	0.00	-	-	-

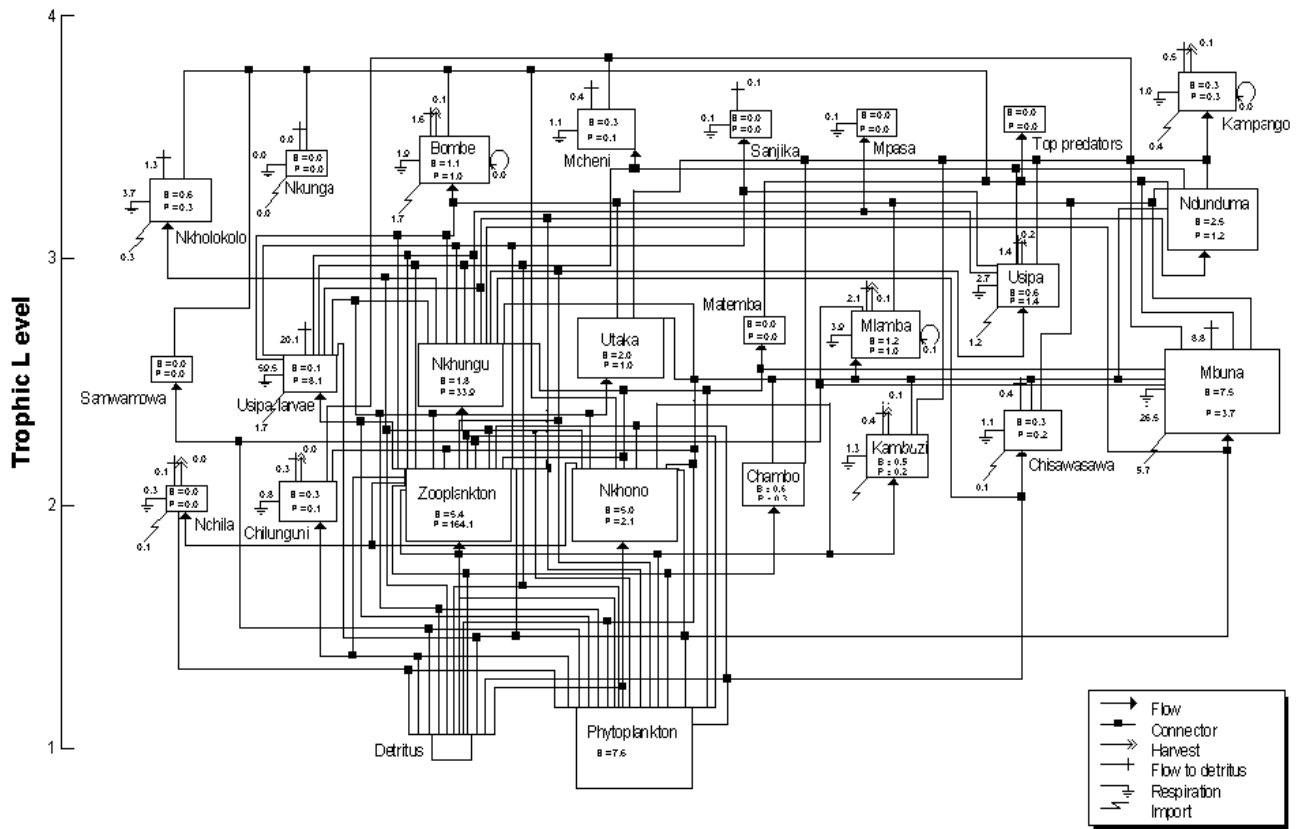

Figure 1. Graphic summarization of the Lake Malawi ecosystem trophic structure between 1977 and 1996.

kambuzi. A limited drop in biomass is also observed in usipa, chilunguni and bombe. However only two fish groups; nkholokolo and ndunduma gain some biomasses. Mcheni, chisawasawa and mlamba are not affected by a change in the fishing rate. There is a reversal in trends when the fishing rate decreases. Lower groups of usipa larvae, zooplankton and phytoplankton as well as the functional groups that do not currently support active fisheries are not directly affected by varying fishing rates. The only linked group of juveniles and adults in the model, usipa and its larvae, does not produce any smooth simulated pattern. The linkage is thus not effected in the present simulation of Lake Malawi ecosystem.

The effect of varying fishing rate in the traditional and commercial fisheries sectors is in general similar to that observed in Fig. 3. Positions of fish groups, with respect to extent of changes in biomass, are however different. In the traditional fisheries groups, which have the worst biomass reduction, we find mpasa, chambo, kampango, sanjika, kambuzi, utaka and nchila. There is a biomass increase in ndunduma. Biomass gain is only barely perceptible in nkholokolo and chisawasawa. The ratio of biomass over original biomass is close to unity in bombe and mlamba. Fish groups with a marginal

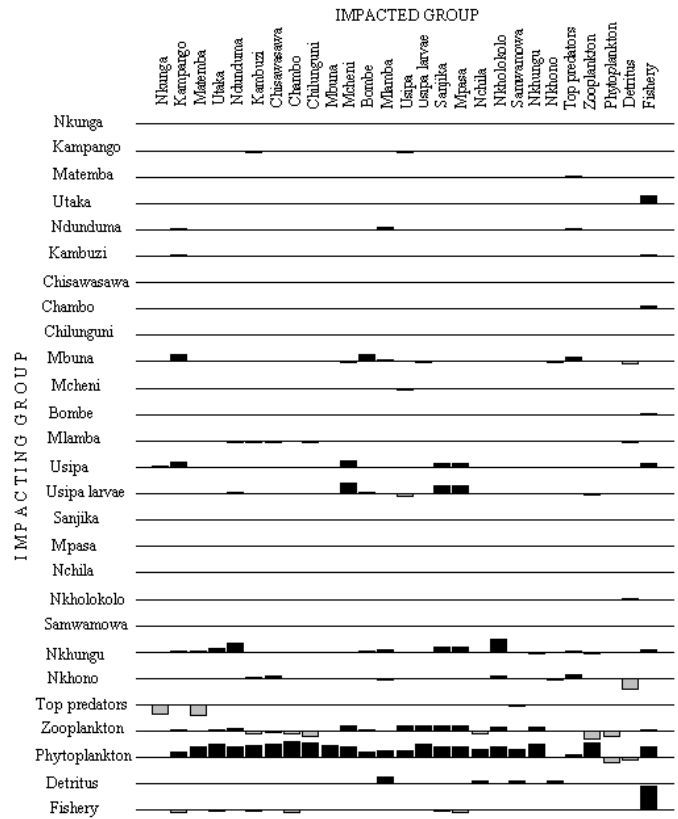
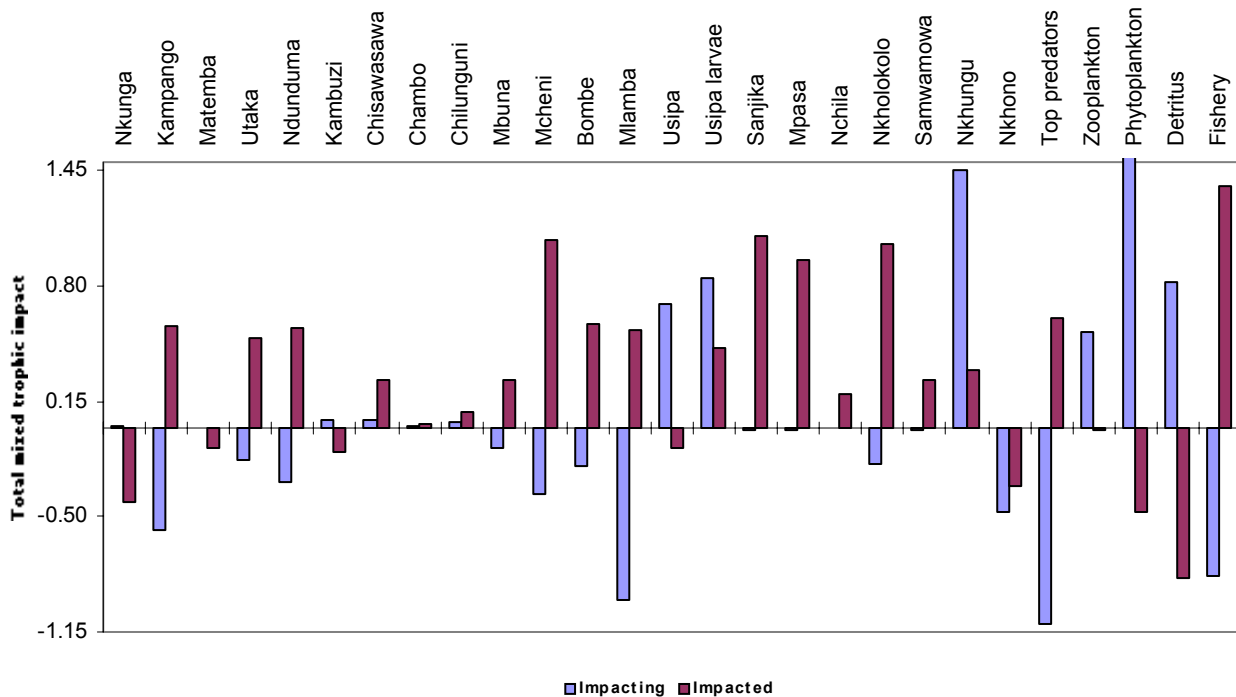

Figure 2a. Mixed trophic impact of the Lake Malawi ecosystem between 1977 and 1996.



**Figure 2b.** Mixed trophic impacts summed up for each functional group in the Lake Malawi ecosystem; impacting value of phytoplankton is 9.23, it is not fully shown in the graph.

decrease in biomass are similar to those in the combined fleet option. For the commercial fisheries decrease in biomass occurs in chambo, utaka, kampango and, to a very limited extent, chisawasawa. Kambuzi gains a little biomass. The ratio of biomass over original biomass is almost constant in bombe, mlamba, ndunduma and usipa.

occurs in the category of the traditional fisheries at all vulnerabilities. In the management goal of optimizing social (employment) value (MS2), commercial fisheries category has two outlier E/S effort ratios of 20.37 and 20.09 at vulnerability levels of 0.7 and 0.5 respectively. These are omitted from Figure 4b.

Figure 4 shows the optimized 'end over starting effort' (E/S) ratios for the management goals in the model fishing policy searches. Optimization of fisheries decreases effort in the management goals. There are, however, a number of instances that optimize specific fishing policy objectives at efforts above the base levels. These occur in all the management goals except for that of optimizing mandated rebuilding of species (MS3). For the management goal of optimizing economic value (MS1), effort above the base level oc-

Other efforts exceeding the starting levels are in traditional fisheries category at all vulnerabilities as well as in categories of total and social values

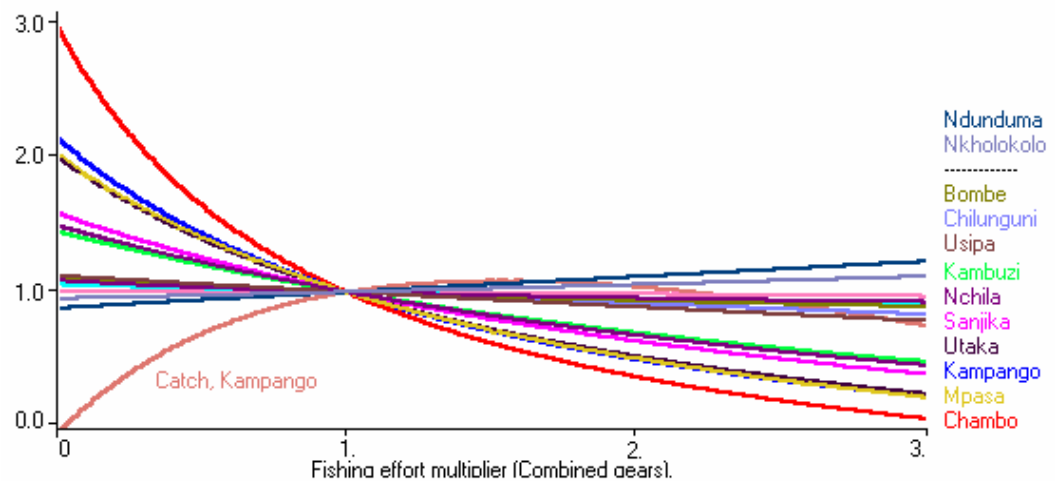

**Figure 3.** Trends of the ratios of biomass over starting biomass in the species-based fisheries in Lake Malawi when fishing rate varies over a twenty-year simulation period while applying a mixed control regime or vulnerability of 0.25 for model equilibrium biomass simulation.

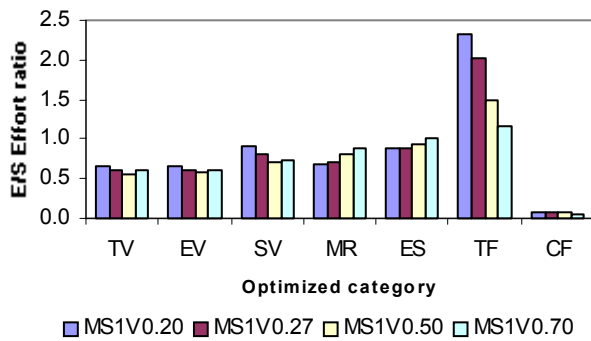

Fig. 4a

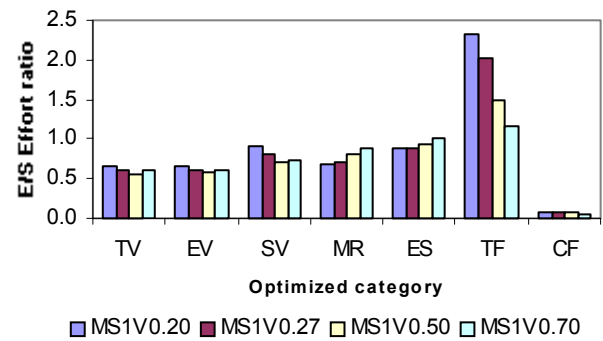

Fig. 4a

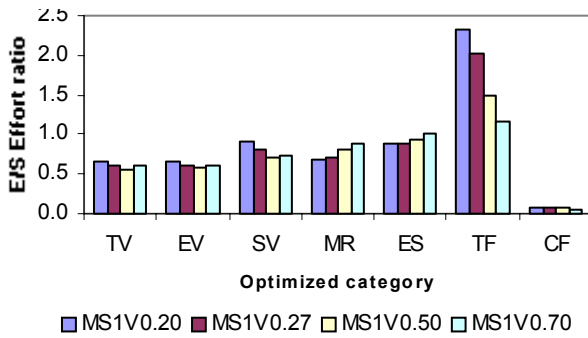

Fig. 4a

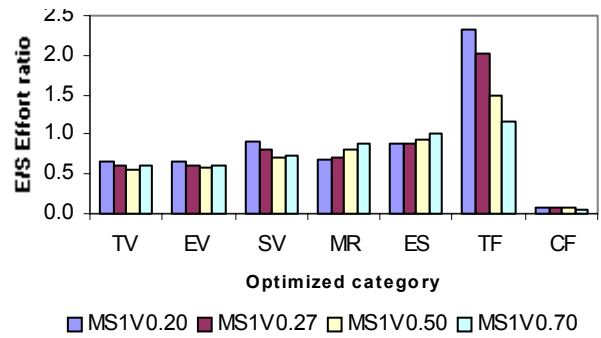

Fig. 4a

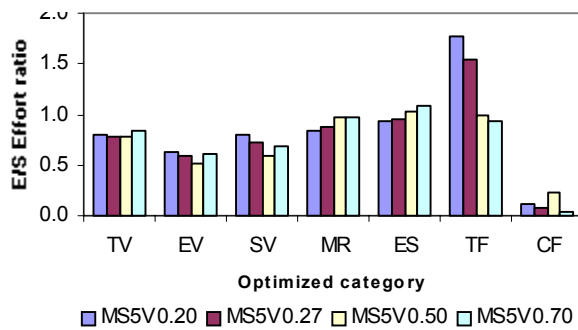

Fig. 4e

**Figure 4.** E/S effort ratios simulated for the different vulnerabilities in the management goals of optimizing economic value (MS1, 4a); social (employment) value (MS2, 4b); mandated rebuilding of species (MS3, 4c); ecosystem structure (MS4, 4d); and all objectives (MS5, 4e). The optimized categories in each management goal is represented by abbreviations TV for total value, EV for economic value, SV for social value, MR for mandated rebuilding, ES for ecosystem structure, TF for traditional fisheries, and CF for commercial fisheries.

at vulnerability 0.7. The only negative E/S effort ratio value of -0.84 also occurs in MS2 for the economic category at vulnerability 0.5. In MS3 decreased effort ratios are in categories of economic and social values while in the rest they are almost unity. The management goal of optimizing ecosystem structure (MS4) generates effort levels that increase with vulnerabilities for ecosystem structure and total value categories.

The E/S effort ratios for MS4's mandated rebuilding category remain at unity. In the remaining optimized categories of MS4, effort decreases at all vulnerabilities. The heaviest drop is in traditional fisheries category. The management goal of optimizing all objectives (MS5) has above base effort in traditional fisheries category at vulnerabilities 0.2 and 0.27 as well as ecosystem structure category for vulnerability levels of 0.5 and 0.7. If equilibrium biomass vulnerabilities (i.e., with maximum of 0.29) are taken into account, only vulnerabilities of 0.2 and 0.27 may be focused on. In

this case E/S effort ratios above unity fall in the 1.086 - 3.093 range and are obtained in the traditional fisheries category for MS1, MS2 and MS5. For MS4 they are in the total value and ecosystem structure categories.

Figure 5 shows catch trends for the traditional and commercial fisheries in all the management goals. The traditional fisheries catch ratios have similar trends to those of total fisheries for almost all cases. E/S catch ratios in the management goals are either unity or less except in MS4 (Fig. 5d). In MS1 catch ratios increase for the traditional fisheries as the vulnerabilities rise. The commercial fisheries' catch ratios decrease at vulnerabilities between 0.2 and 0.27 and rise again through to vulnerability 0.7.

The catch ratios in MS2 are lowest at vulnerability 0.5. In MS3 the E/S catch ratios are unity at vulnerabilities 0.2 and 0.27 but they are lower at



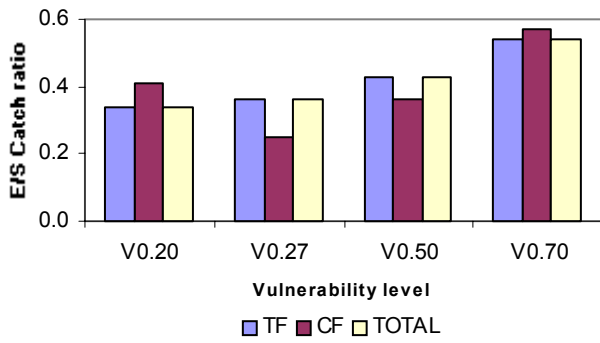

Fig. 5a

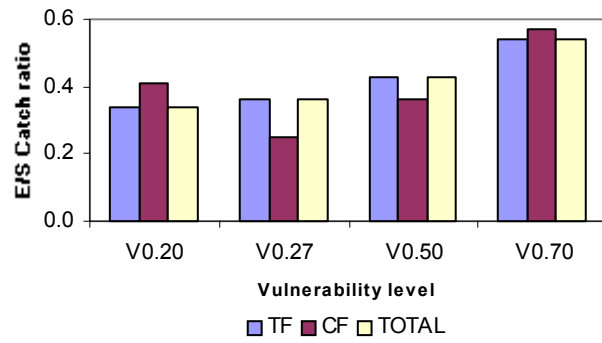

Fig. 5a

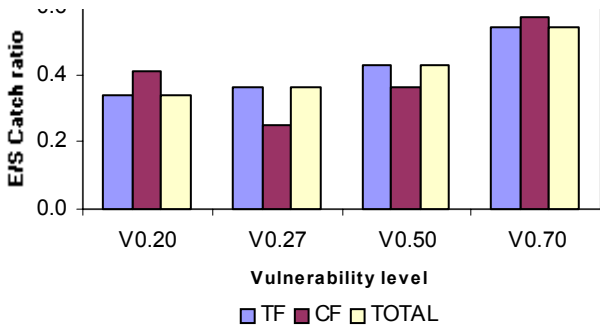

Fig. 5a

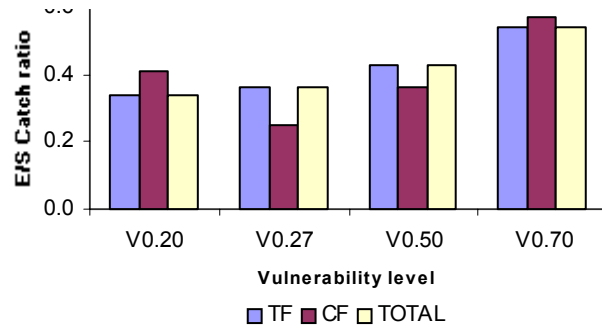

Fig. 5a

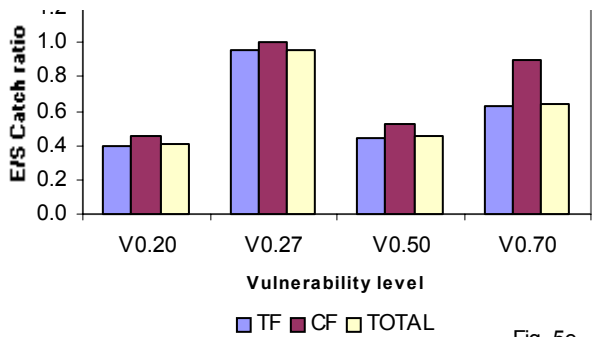

Fig. 5e

**Figure 5.** E /S catch ratios simulated at the different vulnerabilities in the management goals of optimizing economic value (MS1, Fig. 5a); social (employment) value (MS2, Fig. 5b); mandated rebuilding of species (MS3, Fig. 5c); ecosystem structure (MS4, 5d); and all objectives (MS5, Fig. 5e) for the optimized categories of traditional (TF), commercial (CF) and total fisheries.

vulnerabilities 0.5 and 0.7. In MS4 and MS5 commercial fisheries obtain higher E/S catch ratios than traditional or total fisheries at all vulnerability levels. The fisheries simulated values mirror trends of the catches. At 1996 prices, Lake Malawi fisheries obtain in Malawi kwacha per tonne (MWK/t) a total value or market value of 8204.48; total fixed cost of 689.9; total variable cost of 2375.1; total cost of 3065.01; and profit of 5139.47. Considering that only the traditional fisheries catch has been used as input for model simulation, the summary values fall short of actual values by at least 15 %, which is the average contribution of the commercial fisheries to the lake's total landings. The cost does not change in commercial fisheries for all management goals. Traditional fisheries do not generate any costs probably due to nil fixed cost entry in Table 5.

Table 8 details the values of performance indicators at all vulnerability levels in the management strategies for both open and close loop model simulations. Within performance indicators

higher values are in general optimized at lower vulnerability values. Each management goal optimizes fisheries in its own performance indicator, for example, MS1 generates highest values in economic value indicator at all vulnerability levels. However, at vulnerability 0.5, the economic indicator is optimized in MS2 instead of in MS1. Optimized indicator values are higher in open loop than in closed loop simulations. There are a few exceptions, though. The close loop has higher indicator values for mandated rebuilding and ecosystem structure in MS2 at vulnerability 0.27. The same occurs at a vulnerability of 0.7 for mandated rebuilding indicator in MS4. Values of performance indicators are similar, again, for mandated rebuilding in MS3 and MS4 at vulnerabilities of 0.2, 0.27 and 0.5. Both mandated rebuilding and overall value optimize the same values in open and closed loops at vulnerabilities of 0.2, 0.27 and 0.5 in MS4. Only vulnerability 0.7 has similar overall indicator value in MS4 for open and closed loops

**Table 8.** Values of performance indicators at all the vulnerability levels in the management strategies for both the open (left column) and closed (right column) loop model simulations.

Management Strategy & Vulnerability	Performance indicator									
	Net Economic Value		Social (Employment) Value		Mandated Rebuilding		Ecosystem Structure		Overall Value	
	<i>open</i>	<i>closed</i>	<i>open</i>	<i>closed</i>	<i>open</i>	<i>closed</i>	<i>open</i>	<i>closed</i>	<i>open</i>	<i>closed</i>
MS1 V=0.20	196232.07	160825.20	202222.15	152294.40	96.51	94.58	523.90	520.83	0.66	0.54
MS2 V=0.20	181348.42	157433.70	210633.04	160456.30	68.74	68.56	480.89	480.68	0.94	0.71
MS3 V=0.20	145361.09	119597.00	124797.74	94968.30	140.00	138.71	596.43	594.45	1.00	0.99
MS4 V=0.20	20430.82	16943.53	13410.77	10181.65	140.00	140.00	653.18	652.97	1.10	1.10
MS5 V=0.20	185061.69	148620.00	180019.30	134432.70	117.86	116.32	558.49	555.99	3.20	2.86
MS1 V=0.27	182134.68	146312.30	184661.03	135347.90	99.86	98.52	531.56	529.50	0.62	0.50
MS2 V=0.27	168508.93	145273.90	192192.38	146155.90	70.20	71.01	487.50	488.71	0.85	0.65
MS3 V=0.27	145687.47	118361.80	125029.85	93190.99	140.00	138.35	596.12	594.08	1.00	0.99
MS4 V=0.27	19853.77	16125.13	12436.20	9311.55	140.00	140.00	667.17	667.02	1.12	1.12
MS5 V=0.27	171472.05	136391.90	164458.43	122449.90	123.04	121.17	567.98	564.99	3.14	2.82
MS1 V=0.50	168251.32	131335.40	160457.91	117728.00	112.94	111.85	557.33	554.86	0.57	0.44
MS2 V=0.50	157890.96	132197.80	166253.75	126211.50	79.23	79.02	507.84	507.61	0.74	0.56
MS3 V=0.50	146180.85	118154.00	124911.92	93813.05	140.00	137.43	597.63	593.57	1.00	0.98
MS4 V=0.50	16425.13	12918.34	9123.84	6786.05	140.00	140.00	736.43	736.09	1.24	1.24
MS5 V=0.50	153458.06	119563.90	134500.34	99911.05	136.57	135.25	612.48	608.84	3.12	2.84
MS1 V=0.70	182582.18	134848.90	162186.55	115608.70	123.95	121.98	601.41	596.40	0.62	0.46
MS2 V=0.70	177840.06	133383.00	166643.20	118465.60	105.10	103.28	556.33	551.89	0.74	0.53
MS3 V=0.70	147025.09	116589.60	125167.47	92295.85	140.00	137.18	598.83	593.86	1.00	0.98
MS4 V=0.70	19088.30	14118.69	9802.95	7039.81	139.94	139.95	837.92	837.49	1.41	1.41
MS5 V=0.70	176321.30	126592.30	151987.72	105538.60	136.29	135.74	647.64	641.18	3.33	2.94

## Discussion

Increasing the predation on phytoplankton and detritus lowers the mean trophic level of the Lake Malawi ecosystem. Reducing a part of consumption on zooplankton to mainly phytoplankton and detritus in most groups that feed on zooplankton, shifted the mean trophic level from 3.8 in Nsiku (1999) to 3.7 in the present model run. *Chaoborus edulis* and *E. sardella* larvae link to more trophic groups at the top than other middle level groups except for zooplankton. The two groups together with predatory zooplankton, *Mesocyclops a. aequatorialis*, are main users of secondary production and form the main pathway through which energy flows to top trophic levels in the Lake Malawi ecosystem from the low trophic levels of phytoplankton and herbivorous zooplankton (Allison *et al.* 1995a). The trophic structure of the lake system seems to decline with time, similar to occurrence of 'feeding down the food web' (Pauly *et al.* 1998). The species which appear in the pelagic zone of the central Lake Malawi ecosystem (Degnbol 1993) or the pelagic zone ecosystem (Allison *et al.* 1995a) and current model, occupy lower trophic levels in the latter model (Nsiku 1999). Although there are differences in input data such as longer time span in the current model, most data are from similar sources. Decline of the trophic structure is also demonstrated by analysis of mean maximum length of the lake's catch, which dropped between 1976 and 1996 (Nsiku 1999).

Bombe is among the fish groups with high gross

food conversion efficiency (GE) values or ratios of production over consumption in the lake system. Unlike matemba and usipa (maximum length 3-15 cm) which are small, bombe is large (maximum length 70-150 cm). Matemba species such as *Barbus paludinosus* and *B. trimaculatus* are shown in aquaculture to be prolific spawners and have a high growth potential (Brummett and Noble 1995). Usipa is also fast growing (Thompson 1995). One of the influencing factors for bombe's high GE may be fast growth rate. This agrees with preliminary work on raising bombe in ponds (E. Kaunda *pers. comm.*). Other possible reasons may be the fact that the input P/B is from a different species and model with different ecosystem environment as well as exploitation rates (Nsiku 1999).

The Lake Malawi ecosystem P/R of 2.95 is still on the high side of the 0.8-3.2 range within which most Ecopath models fall (Christensen and Pauly 1993). It is expected that a properly accounted for ecosystem, with respect to its energy flow, would have a P/R close to 1 (Christensen and Pauly 1992). This also occurs in more mature systems. In the case of Lake Malawi, the high P/R may be due to the fact that it is not completely 'mature' in relative terms. Another cause of the problem may be that some parameters such as respiration or effect of items like bacteria are not adequately quantified (Christensen and Pauly 1993). Although detritus impacts the Lake Malawi ecosystem positively, it is not strong. Detritus is also said to be less important in the lake's energy flow (Allison *et al.* 1995a). Detrital flow is low in the

trophic efficiency transfers in the lake system. This provides a clear means to designate the maturity of Lake Malawi ecosystem. Since detrital flow becomes more important in mature systems (Christensen and Pauly 1992; Dalsgaard 1999) it can therefore be safely said that Lake Malawi is still between the early and middle stages of its maturity. However when the formation of the East African Rift Valley is considered as well as the history of Lake Malawi, particularly of its fisheries (Potts 1999; Bertram *et al.* 1942), it may be more appropriate to designate the maturity of the lake to be in its middle stages.

Although Ecosim has some limitations, it is very effective in simulating changes in biomasses given changes in fishing pressure (Walters *et al.* 1997; Christensen *et al.* 2000; Christensen and Walters 2000). The software has properties that are handy in the simulation of the Lake Malawi ecosystem for a period of 20 years. With the specification of the fishing mortalities, which is achieved through fixing vulnerabilities and fishing rates in the model, the Ecosim routine is able to effectively follow changes in fish production and potentials of all biomass pathways for the lake ecosystem during the simulation period. The choice of the model control regime, which is set at 0.25 (mixed control) for the equilibrium biomass fisheries analysis, is plausible. In the present model simulation, smooth trends of biomass over original (Ecopath equilibrium) biomass are only obtained in the vulnerability range of 0.1 and 0.29. The mixed control regime for the Lake Malawi ecosystem is further based on the presence of food supply limitation, i.e. bottom-up control, which is interpreted, at least for this analysis, to have more effect than predation, i.e., top-down control. The chambo studies in the southern part of Lake Malawi (FAO 1993), experience of trophic control in the pelagic zone system in the lake (Allison *et al.* 1995b) and feeding ecology of some of the species (Yamaoka 1991) show this view clearly. The FAO chambo study, after analyzing the 1982 -1986 catches, points out the possibility of factors other than fishing (or predation) to have influenced the fish biomass and production. Allison *et al.* (1995b) found higher planktonic biomasses of organisms, comprising of both producers and consumers, in 1993 than 1992 which leads to increased carbon transfer in the food chain. This constitutes the evidence of their standing biomasses and production rates being controlled by food supply. It is also found that predator control is available through a rapid response of predator populations to increases in prey populations. Yamaoka (1991) emphasizes the food partitioning rather than complete food resource sharing between species which may be as-

sumed to show superabundance of food and thus food supply not to be important in system control. Cichlids of Lake Malawi have a wide range of feeding habits, although many other species compete for the same food resources. There is, thus, resource partitioning in fish feeding behaviour in the lake, particularly among its cichlids. This is shown by stomach content analysis, as well as detailed examination of species that share the same trophic requirements. They exhibit slight but clear variations in feeding ecology with regard to behaviour, sites and habitat.

It is important to focus on the traditional fisheries when exploring fishing policies for Lake Malawi. This is because the sector has the majority of fishing operations on the lake and access to it is free (ICLARM/GTZ 1991; FAO 1993; Donda 1998). It is also difficult to manage (Scholz *et al.* 1997). Factors that further impact management of the sector include limitations in alternative income generating opportunities and access to adequate land, politics or sectoral conflicts, high population and resource constraints on the part of Government (GOM 1989; FAO 1993; Nyambose 1997; Scholz *et al.* 1997). In addition, the main fishing area for the traditional fisheries, inshore pelagic zone, is now fully exploited and expansion of the fish resources is thus not attainable (ICLARM/GTZ 1991; FAO 1993; Menz *et al.* 1995; Banda and Tomasson 1997). Opportunity to extend to offshore is restricted by unsuitability of craft to safely navigate the offshore waters, and gears to catch demersal species (GOM 1989; Thompson *et al.* 1995; Banda and Tomasson 1997).

One modification is made for analysis of fisheries sector landings in Lake Malawi due to unavailability of all commercial catches by species for the model period. However, fisheries have major impact on the lake ecosystem, in addition to other factors such as environmental degradation. Traditional fisheries influence biomass and catch of the functional groups more than commercial fisheries at the equilibrium biomass analysis of fisheries sectors in the lake. The biomass of fish groups, which do not form fisheries in the lake particularly for ndunduma, mbuna, top predators and nkhono, have opposing trends to those of species-based fisheries in response to varying the fishing rates. The differences can be attributed to the fact that diets of the fish groups in the two categories overlap (Table 1). The consequence is that food supply increases when fishing rate is high as exploited fish groups are depleted. Pressure for food increases when fishing rate is reduced affecting the biomasses of some groups including ndunduma, mbuna, top predators and nkhono. This

observation seems to also support the concepts of food partitioning and food supply as a control regime for the lake's ecosystem (Yamaoka 1991; Allison *et al.* 1995b). The variation of fishing rates to above and below the equilibrium biomass level has the effect of reversing outcomes. This is probably due, in part, to vulnerability exchange in the Ecosim routine (Walters *et al.* 1997) as well as the fact that all other parameters for determining the biomass in the Ecopath model do not vary during simulation.

The fishing policy searches optimize the lake ecosystem and its fisheries mainly through decreasing effort. Again, the pervasive effect of the traditional fisheries sector is reflected in the management goal of optimizing all objectives (MS5). The goal optimizes effort above base in the category of the sector's fisheries for the equilibrium biomass vulnerabilities 0.2 and 0.27. Like effort, the catch drops while optimizing the fisheries of the Lake Malawi system. The trend of value in the management goals follows that of the catch. However, summary values for the fisheries in the lake as a whole are quite substantial at the 1996 prices. Reduction of effort and catch to optimize the management goals improves the health status of the lake ecosystem and its fisheries. The main recommendations for the development of fisheries in Lake Malawi from the FAO (1993) study support this view. The study finds chambo stocks fully exploited while the deep-water haplochromine trawl fishery is severely depleted, at least in the southeast arm of the lake. Further, the benefit of reducing effort and catch is in terms of reversing not only degradation of fish resources but also the worsening of environmental conditions. First, there will be regeneration of fish breeding or nesting areas as a result of reduced numbers of gears that are dragged on the lake bottom (Banda and Hara 1994). Second, overfishing will be abated. As a consequence species such as nchila *Labeo mesops* whose catches have been in decline for a long time (Tweddle *et al.* 1994) or overfished in the case of chambo (*Oreochromis* spp.) in Lake Malombe (FAO 1993) may have a chance to rebuild. The danger of certain species, which are not well known disappearing without being noticed (Munthali 1997), can be removed. Finally changes in composition of catch and fish size, which have been noticed in the southern part of Lake Malawi (Turner 1977; Tweddle and Magasa 1989; Turner *et al.* 1995) and are probably continuing to occur, will be stopped.

## Conclusion

The best management goal or fishing policy that optimizes exploitation and conservation of the

fish resources in Lake Malawi is to reduce the current fishing effort. In this way the ecosystem integrity of the lake or its health status, as it is now, will be maintained. Effort and thus catch may only be increased for selected offshore and demersal groups of species such as ndunduma and nkholokolo. It may have been most ideal to develop a 'guarded' fishery for nkhone but locally it is viewed as not edible. The potential lies in exploring a market for the product first. Mbuna has the largest biomass among the fish groups in the lake. It is however not advisable to develop a fishery as the group is also the most diverse in number of species (Ribbink 1991). An established fishery can easily disturb the balance and result in dissemination of some individual species in the mbuna complex. Some of the fish groups may benefit from a period of closure apart from a reduction in fishing effort. The chambo fishery is especially in need of urgent attention. The fisheries of kambuzi, sanjika, mpasa as well as nchila are dwindling. In spite of the fact that utaka and kampango are largely semi-pelagic or demersal in the offshore, which limits the fishing pressure from the majority of fishers in the lake, they are still fully exploited. The six groups also require reassessment and immediate reduction from the current level of fishing effort.

## References

- Allison, E.H., G. Patterson, K. Irvine, A.B. Thompson and A. Menz 1995a. The pelagic ecosystem, p. 351-386. In A. Menz (ed.) The fishery potential and productivity of the pelagic zone of Lake Malawi/Niassa, NRI/ODA. 386 pp.
- Allison, E.H., A.B. Thompson, B.P. Ngatunga, and K. Irvine. 1995b. The diet and food consumption rates of the offshore fish, p. 233-278. In A. Menz (ed.) The fishery potential and productivity of the pelagic zone of Lake Malawi/Niassa, NRI/ODA. 386 pp.
- Arnell, N., B. Bates, H. Lang, J. J. Mugnison and P. Mulholland (Editors). 1996. Hydrology and freshwater ecology, p. 325-363. In R. T. Watson, M.C. Zinyowera and R. H. Moss (eds.) Climate change 1995; impacts, adaptations and mitigation of climate change: Scientific-technical analysis. Cambridge University Press. New York. 878 pp.
- Banda, M. and M.Hara 1994. Habitat degradation caused by seines on the fishery of Lake Malombe and Upper Shire River and its effects. Paper presented at the FAO/CIFA Seminar on Inland Fisheries, Aquaculture and the Environment. Harare, Zimbabwe, 5-7 December, 1994. 12 pp.
- Banda, M. C. and T. Tomasson 1997. Demersal fish stocks in southern Lake Malawi: Stock assessment and exploitation, Government of Malawi, Fisheries Department, Fisheries Bulletin No. 35. 39 pp.
- Banda, M., T. Tomasson and D. Tweddle 1996. Assessment of the deep water trawl fisheries of the southeast arm of Lake Malawi using exploratory surveys and commercial catch data, p. 53-75. In I.G. Cowx

- (ed.) Stock assessment in inland fisheries. Fishing News Books/Hartnolls Ltd. Cornwall. 513 pp.
- Barel, C.D.N., R. Dorit, P.H. Greenwood, G. Fryer, N. Hughes, P.B.N. Jackson, H. Kawanabe, R. H. McConnell, M. Nagishi, A.J. Ribbink, E. Trewavas, F. Witte and K. Yamaoka 1985. Commentary: Destruction of fisheries in Africa's lakes. *Nature* 315: 19-20.
- Beadle, L.C. 1974. The inland waters of tropical Africa: An introduction to tropical limnology, Longman, London. 365 pp.
- Berlin, B. 1992. Ethnobiological classification: Principles of categorization of plants and animals in traditional societies. Princeton University Press, Princeton. 335 pp.
- Bertram, C. K. R., H. J. H. Borley and E. Trewavas 1942. Report on the fish and fisheries of Lake Nyasa. Published on behalf of the Government of Nyasaland [Malawi] by the Crown Agents of the Colonies, London. 181 pp.
- Brummett, R.E. and R. Noble 1995. Aquaculture for African smallholders. Manila, Philippines. ICLARM Tech. Rep. 46. 69 pp.
- Bundy, A. 1997. Assessment and management of multispecies, multigear fisheries: a case study from San Miguel Bay, Philippines. Ph.D. Thesis University of British Columbia, Vancouver, B.C., Canada. 396 pp.
- Christensen, V. and D. Pauly 1992. A guide to Ecopath II software system (version 2.1). ICLARM. Software. 6. 72 pp.
- Christensen, V. and D. Pauly. 1993. Flow characteristics of aquatic ecosystems. Pages 338-352 in V. Christensen and D. Pauly (eds.) Trophic models of aquatic ecosystems. ICLARM Conf. Proc. 26. 390 pp.
- Christensen, V, C.J. Walters and D. Pauly. 2000. Ecopath with Ecosim: a User's Guide, October 2000 Edition. Fisheries Centre, University of British Columbia, Vancouver, Canada and ICLARM, Penang, Malaysia. 130 pp (accessible on website <http://www.ecopath.org>).
- Christensen, V. and C.J. Walters 2000. Ecopath with Ecosim: methods, capabilities and limitations. 26 pp. (accessible on website <http://www.fisheries.ubc.ca>).
- Dalsgaard, A.J. 1999. Modelling the trophic transfer of beta radioactivity in the marine food of the Enewetak Atoll, Micronesia. MSc. thesis. University of British Columbia, Vancouver, B.C., Canada. 125 pp.
- Degnbol, P. 1993. The Pelagic Zone of Central Lake Malawi: A Trophic box model. Pages 110-115 in V. Christensen and D. Pauly (eds.) Trophic models of aquatic ecosystems. ICLARM Conf. Proc. 26. 390 pp.
- Donda, S. 1998. Fisheries co-management in Malawi: Case study of Lake Chiuta fisheries, p.21-39. In A.K. Norman, J.R. Neilsen and S. Sverdrup-Jensen (eds.) Fisheries co-management in Africa. Fish. Comgmt. Res. Project, Res. Rpt. 12. 326 pp.
- Eccles, D. H. 1962. An internal wave in Lake Nyasa (now Malawi) and its probable significance in the nutrient cycle. *Nature* 194(4831): 832-833.
- FAO 1993. Fisheries management in the southeast arm of Lake Malawi, the Upper Shire River and Lake Malombe, with particular reference to the fisheries on chambo (*Oreochromis* spp.). CIFA Technical Paper. No. 21. Rome, FAO. 113 pp.
- Government of Malawi (GOM) 1989. Statement of development policies, 1987-1996. Government Printer, Zomba, Malawi. p. 1-21, 42-48.
- Government of Malawi and United Nations in Malawi (GOM/UN) 1992. The situation analysis of poverty in Malawi (Draft). UNICEF. Lilongwe. 202 pp.
- Government of Malawi 1997. Economic report 1997. Ministry of Economic Planning and Development, Government Printer, Zomba, Malawi. 118 pp.
- ICLARM/GTZ 1991. The context of small-scale integrated agriculture-aquaculture in Africa: a case study of Malawi. ICLARM Stud. Rev. 18. 302 pp.
- IMF 1998. IMF approves third annual ESAF credit for Malawi, Press release No. 98/63. IMF, Washington, D.C. 14 pp (accessible on website <http://www.imf.org>).
- Malawi Fisheries Department (MFD) 1996. Fisheries statistics (unpublished). 12 pp.
- Menz, A. (ed) 1995. The fishery potential and productivity of the pelagic zone of Lake Malawi/Niassa, NRI/ODA, 386 pp.
- Munthali, S.M. 1997. Dwindling food-fish species and fishers' preference: problems of conserving Lake Malawi's biodiversity. *Biodiversity and Conservation* 6: 253-261.
- Nsiku, E. 1999. Changes in the fisheries of Lake Malawi, 1976-1996: Ecosystem-based analysis. M.Sc. thesis. University of British Columbia, Vancouver, Canada. 217 pp.
- Nyambose, J. 1996. Preserving the future of Lake Malawi. African Technology Forum. MIT 6 p. (accessible on website <http://web.mit.edu/african-tech/www/articles/Lake-Malawi.html>).
- Patterson, G. and O. Kachinjika 1995. Limnology and phytoplankton ecology. Pages 1-67 in A. Menz (ed.) The fishery potential and productivity of the pelagic zone of Lake Malawi/Niassa. NRI/ODA. 386 pp.
- Patterson, G., M.J. Wooster and C.B. Sear 1995. Real-time monitoring of African aquatic resources using remote sensing: with special reference to Lake Malawi. Chatham, UK: Natural Resources Institute. 21 pp.
- Pauly, D., V. Christensen, J. Dalsgaard, R. Froese and F. Torres 1998. Fishing down marine foodwebs. *Science* 279: 860-863.
- Pitcher, T.J. 1994. Results: impact of species changes on fisheries in Lake Malawi. Pages 81-84 in T.J. Pitcher (ed) The impact of species changes in the African lakes. Report to the Overseas Development Administration, London, UK. 213 pp.
- Potts, R. 1999. Executive summary of the workshop report on an NSF/ICDP workshop on scientific drilling on Lakes Malawi and Tanganyika [The Lake Malawi drilling project] October 10-16, 1999 Club Makakola, on the southwestern lakeshore of Lake Malawi. National Museum of Natural History, Smithsonian Institution, Washington (accessible on website <http://malawidrilling.syr.edu/report2.html>).
- Ribbink, A. J. 1991. Distribution and ecology of the cichlids of the African Great Lakes. Pages 36-59. in M.H.A. Keenleyside (ed.) Cichlid fishes: Behaviour, ecology and evolution. Chapman & Hall. Fish and Fisheries Series 2.

- Scholz, U.F., F.J. Njaya, S. Chimatiro, M. Hummel, S. Donda and B.J. Mkoko 1997. Status and prospects of participatory fisheries management programmes in Malawi: A paper presented at the FAO/ODA expert consultation on inland fisheries enhancements, Dhaka, Bangladesh, 7-11 April, 1997. 12 pp.
- Snoeks, J. (ed.) 2000. Report on systematics and taxonomy: SADC/GEF Lake Malawi/Nyasa/Niassa Biodiversity Conservation Project. Tervuren, Belgium [Chapter 1, p. 1-14 of modified report from the editor].
- Thompson, A.B. 1995. Eggs and larvae of *Engraulicypris sardella*, p. 179-199. In A. Menz (ed.) The fishery potential and productivity of the pelagic zone of Lake Malawi/Niassa, NRI/ODA. 386 pp.
- Thompson, A.B., E.H. Allison and B.P. Ngatunga. 1995. Spatial and temporal distribution of fish in the pelagic waters, p. 201-232. In A. Menz (ed.) The fishery potential and productivity of the pelagic zone of Lake Malawi/Niassa, NRI/ODA. 386 pp.
- Turner, J. L. 1977. Some effects of demersal trawling in Lake Malawi (Lake Nyasa) from 1968 to 1974. *J. Fish. Biol.* 10: 261-271.
- Turner, G. F. 1995. Management, conservation and species changes of exploited fish stocks in Lake Malawi, Pages 335-395 in T.J. Pitcher and P.J.B. Hart (eds.) The impact of species changes in African Lakes. Chapman and Hall. Fish and Fisheries Series 18.
- Turner, G. F., D. Tweddle and R. Makwinja. 1995. Changes in demersal cichlid communities as a result of trawling in southern Lake Malawi, p. 397-412. In T.J. Pitcher and P.J.B. Hart (eds.) The impact of species changes in African Lakes. Chapman and Hall. Fish and Fisheries Series 18.
- Turner, G. F. 1996. Offshore cichlids of Lake Malawi. Cichlid Press. Lauenau. 240 pp.
- Tweddle, D. and J. H. Magasa 1989. Assessment of multispecies cichlid fisheries of the southeast arm of Lake Malawi, Africa. *J. Cons. int. Explor. Mer* 45: 209-222.
- Tweddle, D, S.B. Alimoso and G. Sodzapanja 1994. Analysis of catch and effort data for the fisheries of the South East Arm of Lake Malawi, 1976-1989 with a discussion on earlier data and inter-relationships with commercial fisheries. Malawi Fisheries Department, Fisheries Bulletin No. 13. 34 pp.
- Walters, C., V. Christensen and D. Pauly 1997. Structuring dynamic models of exploited ecosystems from trophic mass-balance. *Reviews in Fish Biology and Fisheries* 7: 1139-1172.
- WWF 1999. Lake Malawi national park, Malawi. International Reports. 1 pp (accessible on website <http://www.panda.org>).
- Yamaoka, K. 1991. Feeding relationships, p. 151-172. In M.H.A. Keenleyside (ed.) Cichlid fishes: Behaviour, ecology and evolution. Chapman & Hall. Fish and Fisheries Series 2.
-

## The use of Ecosim to investigate multispecies harvesting strategies for capture fisheries of the Newfoundland-Labrador shelf

Marcelo Vasconcellos<sup>1</sup>, Johanna Heymans<sup>1</sup> and Alida Bundy<sup>2</sup>

<sup>1</sup>Fisheries Centre, UBC

<sup>2</sup>Bedford Institute of Oceanography, Dartmouth, Nova Scotia

### Abstract

This paper evaluates the policy optimization routine of Ecosim using as case study the model of the Newfoundland-Labrador shelf for the period 1985-1987. The routine is used to calculate the best combination of harvesting strategies for multiple fleets and to illustrate the type of tradeoffs expected when fisheries management aims at maximizing economic, social and ecological goals. To maximize social and economic returns from the fishery the optimization routine drives the ecosystem to a very simplified state where high trophic level species are depleted and low trophic level species have a net increase in biomass after 20 years of simulation. To maximize ecological stability the model predicts in almost all cases a substantial decrease in all fishing fleets. The performance of calculated optimal harvesting strategies are generally affected by increasing errors in stock assessment procedures. More realistic analysis of future fisheries management policies for the Newfoundland-Labrador shelf will require more accurate data for prices per species, fleet operational costs, employment indicators for each fishery, and also ecological parameters that better represent the current status of the ecosystem

### Introduction

The objective of this paper is to evaluate the use of Ecosim, a quantitative ecosystem model structured from Ecosim mass-balance assessment, in

the analysis of the ecological and socio-economic impacts of hypothetical fisheries strategies for the Newfoundland-Labrador shelf marine ecosystem. A mass balance model of the Newfoundland-Labrador shelf for the period 1985-1987 ( Fig. 1; Bundy *et al.*, 2000) was used in the simulation of the impact of fisheries strategies. The model represents the main functional groups, trophic flows and fisheries in the Northwest Atlantic Fisheries Organization (NAFO) areas 2J3KL and 3NO, corresponding to the regions of the Labrador shelf, the Northeast Newfoundland shelf and the Grand Bank, from the coast to the 1,000 m isobath. A total of 31 functional groups are represented in the model, including phyto- and zooplankton, benthic organisms, invertebrate stocks, pelagic and demersal fish stocks, seabirds, seals and whales. Also, three species of fish, Northern cod, Greenland halibut and American plaice were divided into adult and juvenile pools to account for ontogenetic differences in diets. The largest and most important fish stock in the region was the Northern cod. The model represents a period of relatively constant abundance of the main commercially harvested groundfish stocks, prior to the collapse of the Northern cod stock. Five main fleet types are represented in the model (Table 1): inshore trawlers, offshore trawlers directed to cod, American plaice and other groundfish species, mixed gear (including seine nets, gillnets and lines), foreign trawlers, and fleets targeting seals and seabirds.

The analysis aimed at using the policy optimization routine in Ecosim to define i) the best combination of harvesting strategies (relative fishing effort) according to different goal functions, and ii) to calculate the expected or achievable performance when errors in stock assessment procedures over time are accounted for (closed loop scenario).

**Table 1:** Catches and trophic level of the species caught by 5 fleet types of the Newfoundland-Labrador shelf region represented in the model. TL = Trophic level.

Harvested groups	TL	Inshore trawlers	Offshore trawlers	Mixed gears	Foreign trawlers	Sealing and seabirds	Total
Greenland halibut >40cm	4.5		0.004	0.017	0.016		0.037
Harb Seals	4.4					0.001	0.001
Greenland halibut <=40cm	4.3		0.001				0.001
Seabirds	4.2					0.001	0.001
Cod > 35cm	4.2	0.014	0.257	0.164	0.150		0.585
Large pelagic feeders	4.2			0.002	0.003		0.005
Piscivore small pelagic fish	4.1			0.015	0.001		0.016
Skates	4.0				0.030		0.030
American plaice <=35cm	3.7		0.004		0.016		0.020
Redfish	3.7	0.001	0.042	0.001	0.132		0.176
American plaice >35cm	3.6	0.003	0.059	0.009	0.029		0.100
Large demersal feeders	3.4	0.002	0.012	0.007	0.036		0.057
Capelin	3.3			0.082	0.044		0.126
Planktivore small pelagic fish	3.3			0.019	0.001		0.020
Flounders	3.1	0.002	0.033	0.004	0.039		0.078
Large Crustacea	2.9			0.016			0.016
Shrimp	2.5		0.001		0.002		0.003
Total by fleet		0.022	0.413	0.336	0.499	0.002	1.272

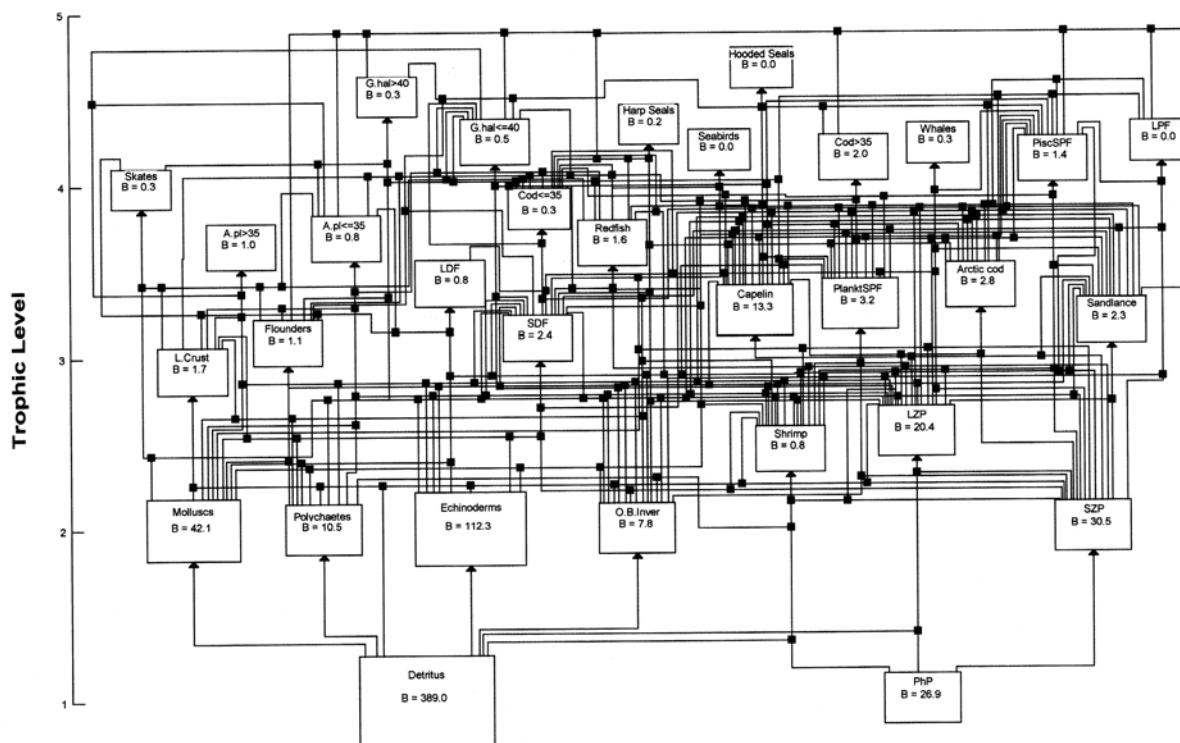

**Figure 1.** Trophic model of the Newfoundland-Labrador shelf area during the 1985-1987 period (Bundy *et al.*, 2000).

## Methods

Three performance indicators are used by the optimization search procedure (Christensen *et al.*, 2000):

*Net economic value:* measured as the total landed value of catch minus total operating cost over a 20 year period, with a discount rate of 4%. Operating costs were assigned to fixed costs (35% of total value) and effort-related costs (20% of total value) for all fleets.

*Employment:* measured as the product of the gross landed value of the catch and the jobs per landed value ratio for each fleet, i.e. inshore trawlers (5); offshore trawlers (1); mixed gears (5); foreign trawlers (0.1); seals and seabirds fleet (5).

*Ecological stability:* measured by the departure (negative) of species biomasses over time from target biomass levels specified for each functional group. Ecological stability attempts to capture the importance of each species/group to the overall 'health' of the ecosystem, as defined by managers. During simulations we assumed that whales, seals, seabirds and cod are important for managers and that it is their goal to rebuild the biomass of these groups to 3 times the baseline Ecopath value. Additionally, we tested species weightings proportional to the inverse of the P/B ratio, which provided similar qualitative results.

By assigning weights to each of the three indicators it was then possible to define different management goals and strategies (Table 2) (*and see*

*Cochrane this volume*). Besides the three management goals in Table 2, we examined how policies would change in response to increasing weights to ecological stability, starting from an equal weight scenario (1 to economic, 1 to employment, and 1 to ecological stability).

Simulations were run under two trophic control scenarios, expressed by the value of the prey vulnerability parameter:  $v=0.4$  and  $v=0.6$ .

During simulations adult and juvenile Greenland halibut presented alternated cycles in abundance that forced us to adjust feeding time to increase model stability (ca. 13% of the diet of adult halibut is made of juvenile halibut). Feeding time factor of adult and juvenile Greenland halibut was thus set to 0, thus feeding time and hence the time exposed to predation is forced to remain constant, and less dependent on changes in prey availability.

**Table 2.** Management goals and performance indicators used in the optimization procedure.

Management goal	Weights for performance indicators		
	Net economic value	Employment	Ecological stability
Maximize net economic value	1.000	0.0001	0.0001
Maximize employment	0.0001	1.000	0.0001
Maximize ecological stability	0.0001	0.0001	1.000



**Table 3.** Performance indicators of optimal policies (relative Fs) under two trophic control (= vulnerability) scenarios (v=0.4 and 0.6).

Goal	V=0.4			V=0.6		
	Eco-nomic	Social	Ecologi-cal	Eco-nomic	Social	Ecologi-cal
<i>Performance</i>						
Net economic value	155.4	87.4	8.8	292.2	240.6	42.1
Employment	1027.1	1101.8	17.5	1562.6	1782.2	24.6
Ecological stability	-709.0	-727.1	-420.3	-1027.3	-632.5	-407.2
Overall	3.3	10.7	-1.2	6.2	17.2	-1.1
<i>Optimal Fs by fleet</i>						
Inshore trawlers	0.4	2.8	0.5	1.1	7.3	0.6
Offshore trawlers	0.1	20.1	0.1	0.0	21.1	0.2
Mixed gears	20.1	76.8	0.1	274.0	20.4	0.2
Foreign trawlers	6.9	10.2	0.1	24.9	3.8	4.6
Sealing, birds	6.6	13.1	0.1	0.1	3.9	0.1

**Simulation results**

Table 3 shows the results of the policy optimization for three contrasting management goals. In order to meet the economic goal of maximizing the net economic return taken from the system the model calculates a reduction in inshore and offshore trawlers and an increase in mixed gears, foreign trawlers and the harvesting of seals and sea birds. In this scenario the best solution seems to be to increase the relative fishing effort of the fleets with highest yields (mixed gears and foreign trawlers), which also target low trophic level species (Table 1), and to deplete the top predators in the system (seals and birds), which are competitors to fisheries.

To meet the social goal of maximizing employment the optimal policy involves an increase in all fishing fleets, particularly mixed gears that have a higher jobs/landings ratio. To maximize ecological stability the model predicts in almost all cases a substantial decrease in all fishing fleets. Predictions of optimal fishing rates and performance values are sensitive to the value of the vulnerability parameter, although the general qualitative pattern of predictions is similar under both trophic control scenarios. Figure 2 shows the resulting changes in species biomass under optimal policies for each management goal. In order to maximize economic return and employment (measured as a variable dependent on landings) the hypothetical manager drives the system to a very simplified state where high trophic level species are depleted and low trophic level species have a net increase in biomass. There are two apparent factors contributing to increasing landings; firstly the increase in fishing pressure on the groundfish stocks (some of them completely collapsed after 20 years); and secondly, the increase in biomass and hence the productivity of lower trophic level species also targeted by fisheries (e.g. shrimps, capelin, planktivorous fish). A more balanced distribution of biomass across the food

web is obtained when the goal is to maximize ecological stability.

Releasing fishing pressure leads to a system that presents at the end of the simulation similar characteristics encountered at the starting condition.

Figure 3 compares policy performance with increasing weight given to ecological stability. Relatively small changes in policy performance occur up to a 1:1:10 weighting to economic, social and ecological goals, respectively,

which is achieved with the following relative fishing rates (Table 4):

**Table 4.** Relative fishing rates.

Inshore trawlers	2.3
Offshore trawlers	0.0
Mixed gears	2.0
Foreign trawlers	0.0
Seals and seabirds	0.0

Increasing the weight for ecological stability even more leads to more drastic changes in the three performance indicators, as well as in the calculated optimal fishing rates (Table 5).

**Table 5.** Optimal fishing rates.

Inshore trawlers	8.6
Offshore trawlers	0.3
Mixed gears	20.5
Foreign trawlers	10.8
Seals and seabirds	0.8

This example is illustrative of the type of tradeoffs encountered when managers aim at balancing ecological and socio-economic goals. Using the simple goal functions specified above, the model predicts that improvements in ecological performance will occur at the expense of substantial losses in socio-economic performance (Figure 3). Interestingly, the optimal policy calculated by the model in the latter scenario is the one that closes fisheries with low jobs/catch ratio (offshore and foreign trawlers) and also the direct harvesting of charismatic fauna.

The effect of the lack of perfect information about stock sizes and the actual fishing mortality on the performance of policies were also considered in the simulations. Ecosim evaluates the performance of fishing strategies in a closed loop scheme where managers have to rely on stock assessment to determine the annual optimal policies.

Typically, errors in stock assessment cause vari-

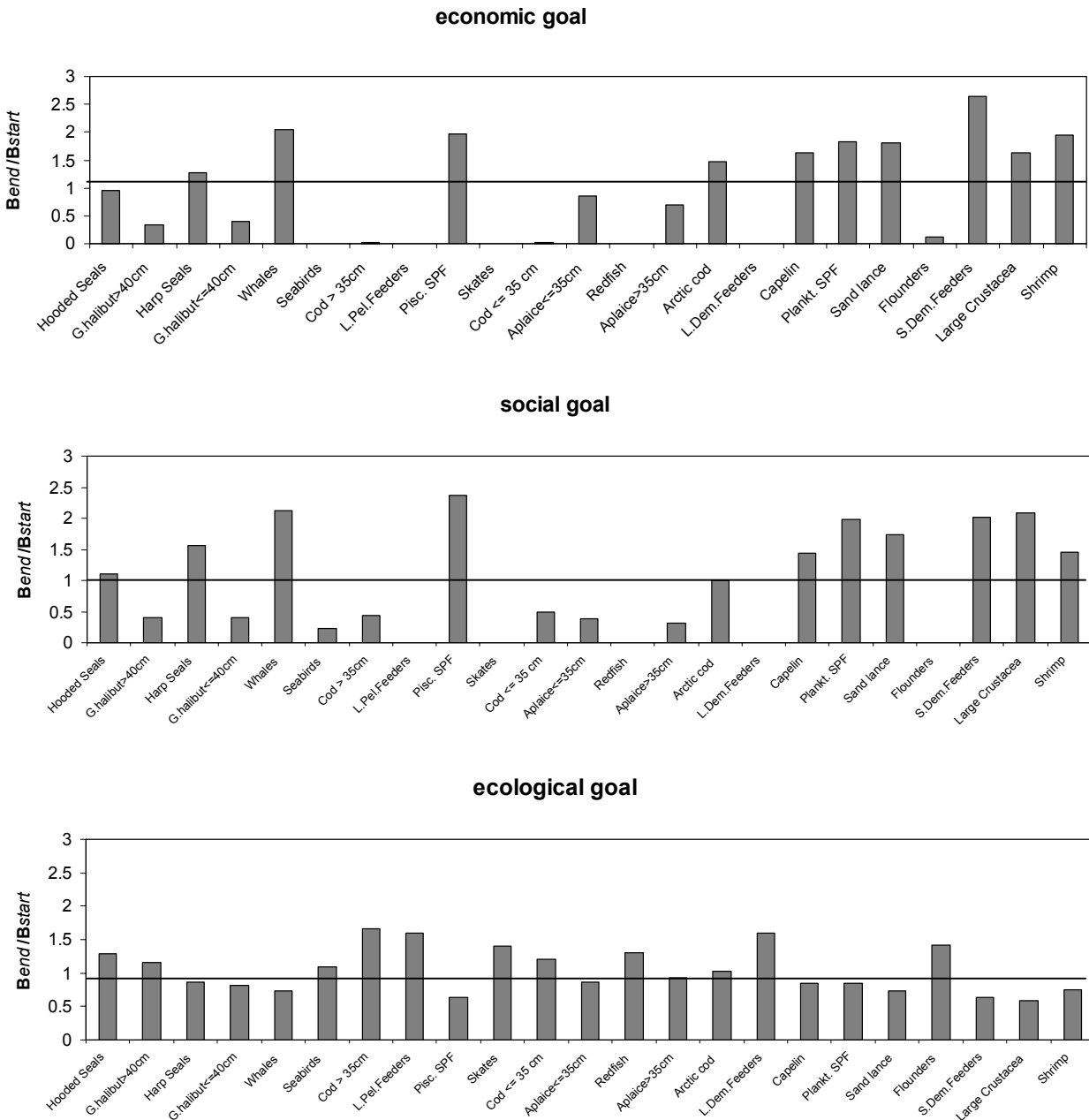

**Figure 2.** Predicted changes in biomass of functional groups of Newfoundland-Labrador shelf model as a result of fishing rates that optimize economic, social and ecological goal functions. Bend/Bstart is the ratio between biomass at the start of the simulation and at the end of 20 years period under the same fishing rate. Results are presented for 23 groups placed in order of decreasing trophic level from left to right.

ability in the implemented fishing rates and hence affect the performance of fishing strategies. In the example below the performance of a policy that optimizes the balance among economic, social and ecological goals is evaluated under three levels of observation errors (Table 6: coefficient of variation of the stock assessment procedure).

We found that there is a general decrease of performance for economic, social and overall indicators, but a slight improvement in ecological performance with increasing error, meaning that the

variability imposed by stock assessment error is predicted to actually attenuate the impact of fishing on ecological stability. In all cases we tested, ecological stability either improved or remained relatively unchanged with increasing assessment

**Table 6.** Coefficient of variation of the stock assessment procedure

	CV=0	CV=0.2	CV=0.5
<i>Economic</i>	150.3	121.6	111.9
<i>Social</i>	1058.5	780.7	702
<i>Ecological</i>	-677.9	-662.6	-657.3
<i>Overall</i>	11.5	8.28	7.33

errors.

### Conclusion

The analysis presented above was not meant to provide a realistic policy evaluation for the model area. Instead the goal was to test the overall behavior of the model under different parameter settings, and to check the consistency of the results according to the different policy scenarios. A more realistic analysis should include better economic data (prices per species, fleet operational costs), better social indicators (such as employment for each fishery) and also ecological parameters that better represent the current status of the system and its ecosystem dynamics. Of particular importance are the vulnerability parameters among species, which seems to influence the magnitude of performance values and optimal fishing rates. When running the policy optimization routine attention should also be given to long term changes in productivity, or oceanic regimes, which might influence the overall performance of policy options considerably.

### References

Bundy, A., Lilly, G. R. and P. A. Shelton 2000. A mass balance model of the Newfoundland-Labrador shelf. Canadian Technical Report of Fisheries and Aquatic Sciences.

Christensen, V., C.J. Walters, and D. Pauly 2000. Ecosim with Ecosim Version 4: Help System. University of British Columbia, Fisheries Centre, Vancouver, Canada and ICLARM, Penang, Malaysia

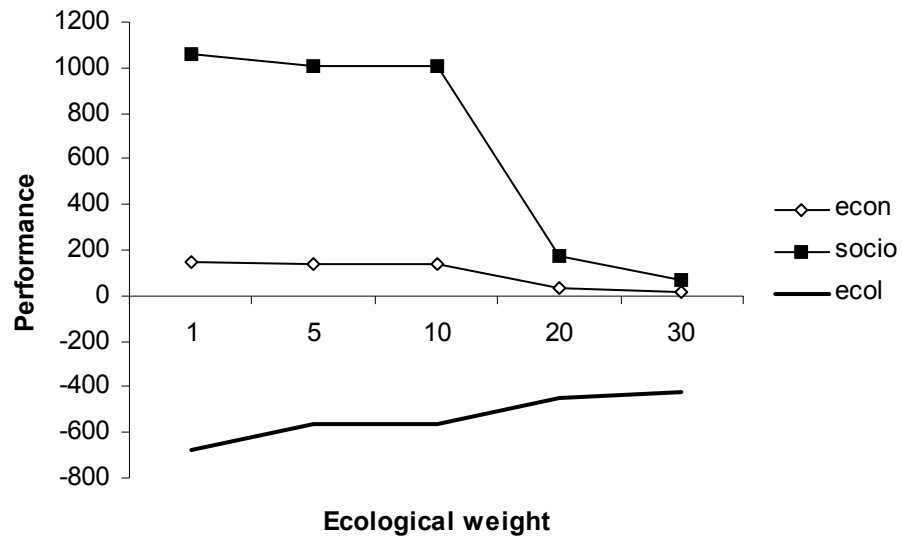

**Figure 3.** Changes in policy performance with increasing weight given to ecological stability. The x axis represents the weight given to ecological stability when economic and social weights are kept constant at 1.

## Simulating management options for the North Sea in the 1880s

Steven Mackinson  
CEFAS, Lowestoft, UK

### Abstract

An Ecopath model of the North Sea in the 1880s, is used here in evaluating the utility of the Ecosim policy simulation routine. The model representation of the North Sea in the 1880s was 're-constructed' by combining present information on trophic linkages of North Sea species with historical scientific and local knowledge. The model captures the period when sailing vessels still predominated and industrialised fishing was on the cusp of explosive development. Evaluation of Ecosim policy simulation routines focussed on sensitivity analysis in relation to: (i) initialisation options of optimisation routines, (ii) the effect of the user input vulnerability flow rate parameter,  $v$ , (iii) parameter settings for the 'closed-loop' analysis of management errors. By providing users with tools to examine various policy options and objectively comparing them using criteria scores, the policy evaluation options contribute great utility to the Ecopath with Ecosim software. However, it is important to re-iterate that users should not interpret criteria scores as providing direction for management advice; results of simulations depend heavily on specific parameter settings used. In particular, simulations are very sensitive to the user input vulnerability flow rate. Specific noteworthy points/ issues arising from the simulations are commented on.

### Introduction: Ecopath Model of The North Sea in the 1880's

Prior to the development of steam fishing vessels in the early 1880s, more than 30,000 sailing fishing vessels, from bordering countries, ploughed the bountiful waters of the North Sea. In the UK alone, fishing and its associated activities provided a livelihood for upwards of 100,000 people. The North Sea was particularly rich in marine life, both in general and in individual populations. Outstripping all in economic and socio-logical significance, how-

ever, was one fish; the herring (Fig. 1). Herring drifters and beam trawling sailing smacks (Fig. 2) dominated the seas with other small vessels engaging in hook and line fishing and crab and lobsters in coastal waters. Trawl fish were classified under the names 'prime' and 'offal'; the former including turbot, brill, soles, and Doreys; the latter comprising plaice, cod, haddocks, gurnards, skate, and "other such kinds as are occasionally caught in the trawl" (Holdsworth 1874) (Fig 3). Combining present information on trophic linkages of North Sea species with historical scientific and local knowledge, an ecosystem model is re-constructed to describe the state of the North Sea ecosystem in the 1880s (Mackinson 2000). The model is 're-constructed' with the aid of a previous model describing the state of the ecosystem in 1980s (Christensen 1995).

### Simulation settings

The 1880's North Sea model consists of 44 groups and 5 fisheries. Trawl and line fisheries are combined in to one group since they catch the same species and no information was readily available to otherwise separate them. Settings used during simulations of various management policy options examined below are detailed in Appendix 1 (Tables i, ii and iii) and made reference to in the text.

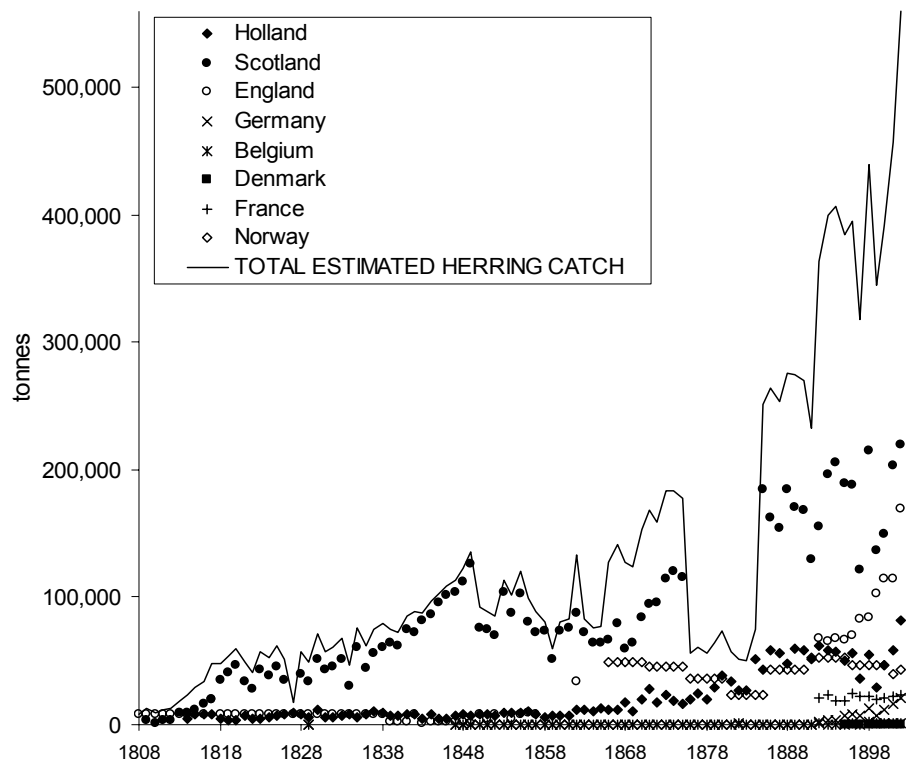

**Figure 1.** Catch of North Sea herring. The apparent sharp dip in catches from the late 1870s to mid 1880s is not real, but due to missing catch statistics for the Scottish fleet during that period.

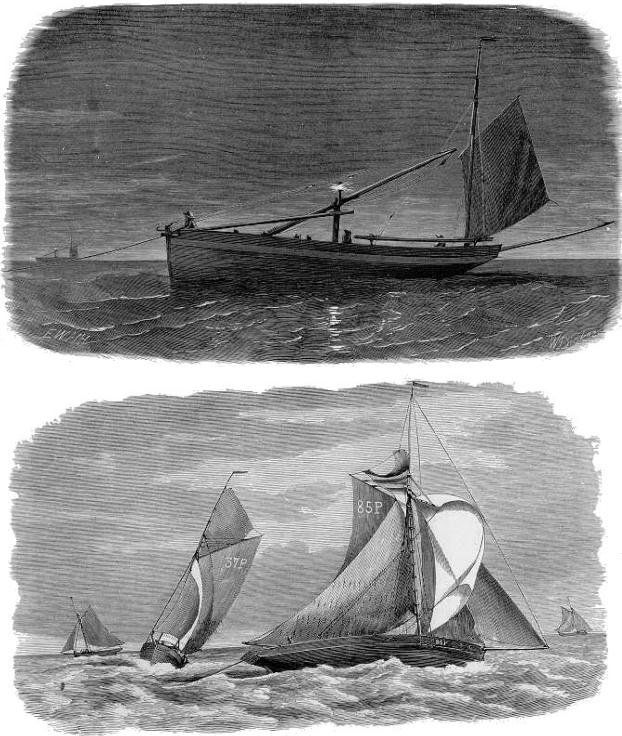

**Figure 2.** Yarmouth Lugger drift net fishing for herring at night (top), and trawling smack towing the trawl (Holdsworth 1874)

*Effect of initialisation options on estimates of relative fishing mortality derived from a search procedure used to define an optimum harvest strategy in terms of fishing mortality for each gear type*

Prior to examining the influence of alternative weightings on the economic, social and ecological importance of management policy options, it was essential to explore the effect of the three initialisation options on the results of the optimum harvest strategy search procedure (conjugate gradient method).

The options for search initialisation were considered individually and combined. Those compared were:

1. Start at Ecopath base values (EB)
2. Random start (R)
3. Start from Ecopath base and restart using Current values (EB+C)
4. Random start and restart using current values (R+C)

For each of the initialisation settings, the search procedure was allowed to run three times. The stability of the relative F estimates was compared between runs and between initialisation options (Fig 4).

Searches starting from Ecopath base (EB) obtained the same consistent relative F values. However, these were considerably different from all other remaining searches. The random search method and combined EB+C and R+C initialisations derived relative fishing mortality estimates in approximately the same ratios for the 5 gear types, although neither consistent nor stable relative F values were derived within or between initialisation options.

Based on these results, for consistency, the strategy used in all subsequent simulations of alternative policy options was to run the search procedure starting at Ecopath base F values, allowing the procedure to run for at least 2 times the number of gear types, then to re-run the search starting from current F values. Unless any relative F values estimates were greater than 20 times the initial F (a constraint within the search procedure indicating that such values are non-

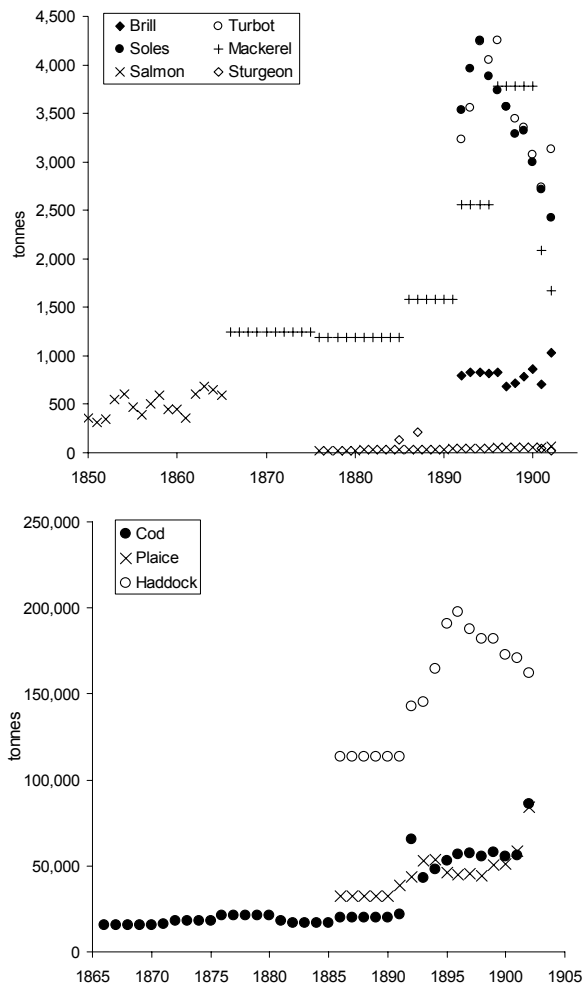

**Figure 3.** North Sea catches of cod, haddock, soles, brill, salmon, sturgeon, mackerel and turbot and plaice from 1850 to 1902.

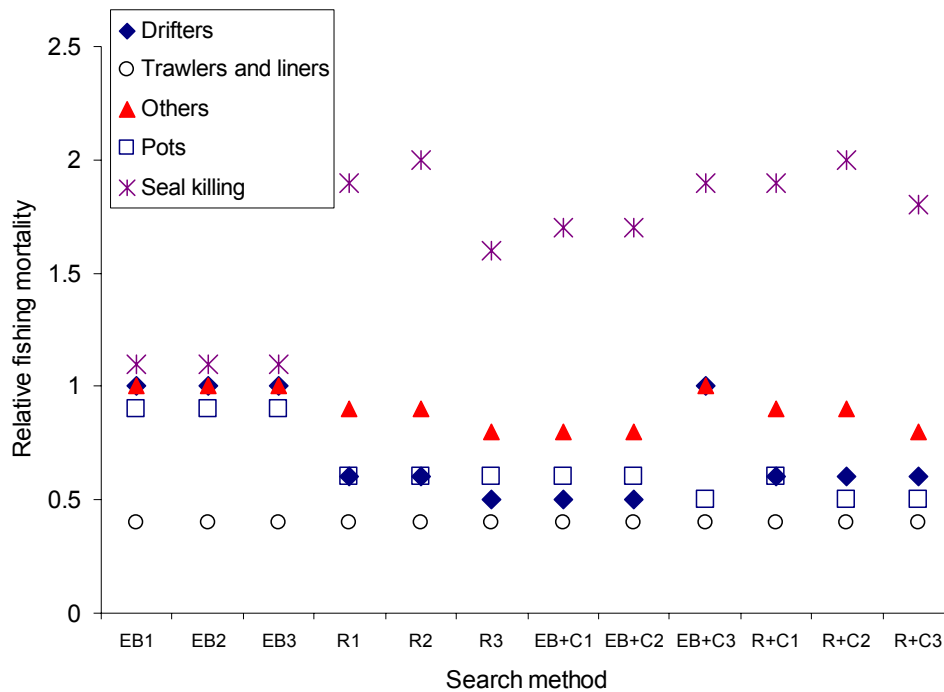

**Figure 4.** Comparison of stability of F estimates from search procedures

sense), the relative F estimates were used in simulations. For the cases where estimated F's exceeded 20 times initial F, the search procedure was run again with a random start and re-run using current F's.

**Influence of flow control parameter**

The flow control (= vulnerabilty) parameter specifies the flow between invulnerable and vulnerable prey, and from prey to predator. Higher values of flow rapidly replenish the vulnerable prey pool from the invulnerable pool, indicating that food is not limiting and thus representing more 'top down' control. Lower values (e.g. 0.2) represent low flow of food, thus representing a 'bottom up' control effect on the predator-prey interactions. Intermediate values (e.g. 0.5) represent mixed control. The flow control thus has important consequences to the dynamics of the interactions in the model and simulations must be compared under various settings. Whilst there are several methods implemented in Ecosim to derive values of flow control between various groups, the present analysis simply compares 3 values of the parameter, each applied as a 'blanket' setting for

all groups in the model.

The effect of flow control on the estimation of F during the search procedure was compared for 4 policy scenarios (see next section for details of scenarios). Values of flow control above 0.6 generally produced unstable dynamics of the model. From Figure 5 it appears there are no apparent trends in the effect of flow control on the estimation of optimum F. In the economic maximisation scenario, lower flow control results in higher estimates of F for most gears, sug-

gesting that fished groups are more resilient at low flow control. However, this observation does not hold true for 'other' gear, nor across alternative policy scenarios. The effect of the flow control on the resilience of a group to fishing is unclear and rather confusing. It appears to fluctuate depending on what group is being fished, and the assumptions of the policy being considered.

I have doubt as to whether or not the lack of 'pattern' in response to changes in flow control is a result of differences in the fishing mortality estimates derived from the search procedure. My conclusion is one of caution; once a particular policy has been chosen, the response to changes in the assumptions of flow control should be thoroughly examined. However, it still remains unclear to me how changes in the flow control effect the response of each group to fishing, since fishing mortality is not directly linked with the flow control parameter.

*Comparison of setting all flow control to v=0.4 with prey vulnerabilities assumed to be proportional to trophic level*

**Table 2.** Weighting assigned to each value component under 4 policy scenarios

Value Component	Value weight for each scenario			
	1. Economic maximisation	2. Social maximisation	3. Ecological maximisation	4. 'Big compromise'
Net economic value	1	0.00001	0.00001	1
Social (employment) value	0.00001	1	0.00001	1
Ecosystem stability	0.00001	0.00001	1	1

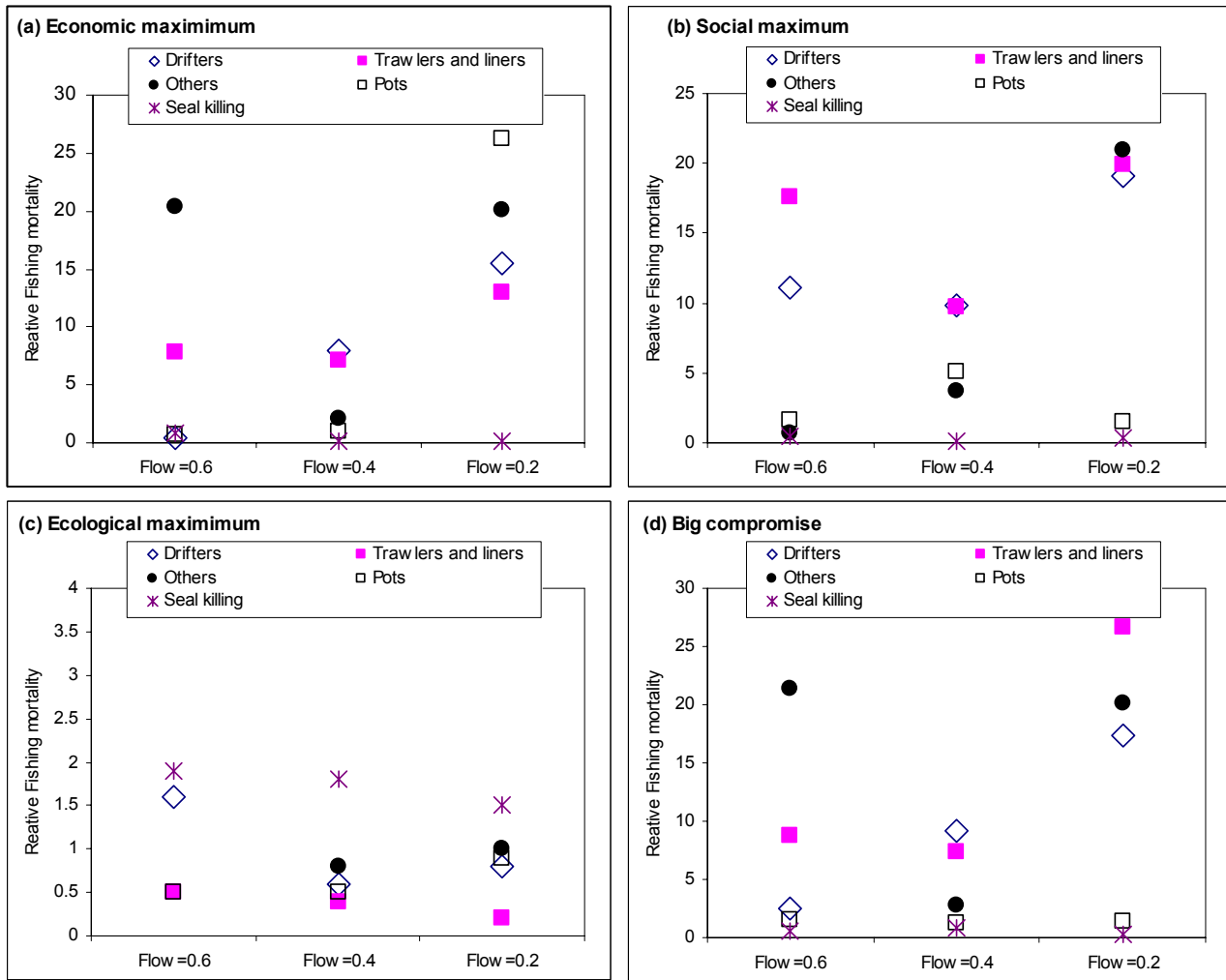

**Figure 5.** Comparison of fishing mortality estimates under 3 flow control assumptions.

Despite those vulnerabilities weighted in proportion to trophic level being quite close to 0.4 for many fish groups (Appendix 1, Table iii), there was apparently a considerable impact on the estimated relative fishing mortalities (Table 1). The search procedure was run several times to ensure similar estimated relative F values were consistently obtained. Despite this obvious difference, closer examination of the simulation results revealed that the impact on the system within 20 years was similar for both fishing strategies. With the exception of seals and salmon & seatrout, the same groups were affected in similar ways (Fig 6). Total system biomass was 1% higher and value 5% higher with  $\nu$  proportional to trophic level than

when flow value of  $\nu=0.4$  is assumed for all groups.

**Results: individual policy simulations**

Tables 2 and 3 below display the policy scenario weightings and the final optimised relative F values for the various gear types under each scenario. Flow parameter setting was  $\nu= 0.4$  for all simulations compared here.

*Scenario 1: Economic Maximisation*

The optimum fishing strategy derived to maximise value of harvest had two main elements.

**Table 3.** Optimum relative optimum F values for each gear type according to each policy scenario

	Relative F (to initial value)			
	1. Economic	2. Social	3. Ecological	4. 'Big compromise'
Drifters	7.9	9.8	0.6	9.2
Trawlers and liners	7.1	9.7	0.4	7.3
Others	2.1	3.7	0.8	2.8
Pots	1	5.1	0.5	1.3
Seal killing	0.1	0.1	1.8	0.9

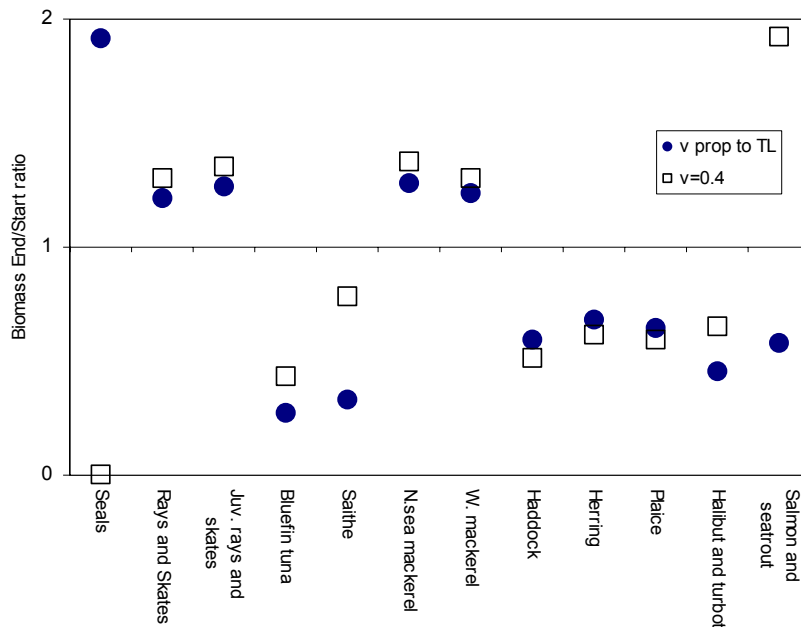

**Figure 6.** Comparison of effects of blanket settings for flow control parameter ( $v=0.4$ ) and weighting of flow parameter proportional to trophic level (determined according to phytoplankton TL=1 with  $v=0.1$ , see Appendix 1, Table iii).

First was to increase the harvest pressure for both the high valued ‘prime’ fish (via trawl gear) and on the lower value, higher volume, herring (via Drifter fleet). The low initial fishing mortalities were increased approximately seven fold in each case. The second element comprised a 2 times increase in F for ‘other’ gear (acting on bluefin tuna, saithe, salmon & seatrout, mackerel, and sprat) which resulted in the main predators herring and ‘prime fish’ being reduced, thus alleviating the predation pressure on them. Ironically, salmon & seatrout ended up benefiting from the increased fishing pressure (on themselves from the ‘other’ gear), as a result of release of euphasiid food, when the herring stock declined. Other ‘winners’ and ‘losers’, (only those whose biomass at the end of the run was  $> \pm 20\%$  that at the start) are shown in Fig 7a. The stocks of herring and ‘prime’ fish were maintained throughout the period despite the early heavy fishing mortality. Total biomass of all groups was 11% less at the end of the run than the start. Whilst there was reduction in total value of the fishery by 32%, total value remained 2 times that of the costs.

*Scenario 2: Social (Jobs) Maximisation*

Attempting to maximise the jobs/catch ratio of the combined fisheries, results in a similar harvest strategy to the economic maximisation policy. This is unsurprising since according to the distribution of average crew sizes (14 for Drifters, 9 for trawlers, 6 for ‘others’, 3 for pots) the largest number of jobs per unit catch would be made

available in the herring fishery, followed by the trawl fishery. Given the large number of processing related jobs generated from the herring fishery, the disparity is probably even larger. Ecosystem effects of the harvest policy are also similar, although of slightly greater magnitude (Fig 7b); herring and ‘prime’ fish are initially reduced due to increased fishing, but this is to some extent mitigated by the increased fishing on their main predators (via ‘other’ gear). After 20 years, the total biomass of the system is reduced by 14%, total value of all fisheries has been reduced by 44%.

*Scenario 3: Ecological Maximisation*

Giving all weight to ecological importance results in a radically different harvest strategy to economic and social scenarios. With the exception of ‘seal killing’, fishing pressure is reduced on all gears under the ecological policy scenario. Fishing pressure on seals is increased because in the settings for ecological importance they are assigned zero importance to reflect the attitude towards seals as simply being pests disturbing salmon fisheries. A higher importance on sturgeon, with an ideal target biomass 2 times higher than original, results in their fishing pressure being reduced and consequent increase in biomass (Fig 7c). Over 20 years, total system biomass and value are 1% and 3% above the initial estimates.

The results appear to be sensitive to changes in the assigned values of ecological importance. Whilst this issue was discussed at length during the workshop, it was not resolved. Present settings (Appendix 1, Table iii) are entirely subjective and simply reflect the users ‘preferences’ for certain groups.

In effect, the importance reflects a desirability factor. Whether or not this bears any resemblance

**Table 4.** Estimated fishing mortalities derived under different assumptions on ecological importance.

	Relative F (to initial value)	
	Subjective weight	1/(P/B) weight
Drifters	0.6	0.8
Trawlers and liners	0.4	0.4
Others	0.8	1.2
Pots	0.5	1
Seal killing	1.8	1



(a) Economic maximisation

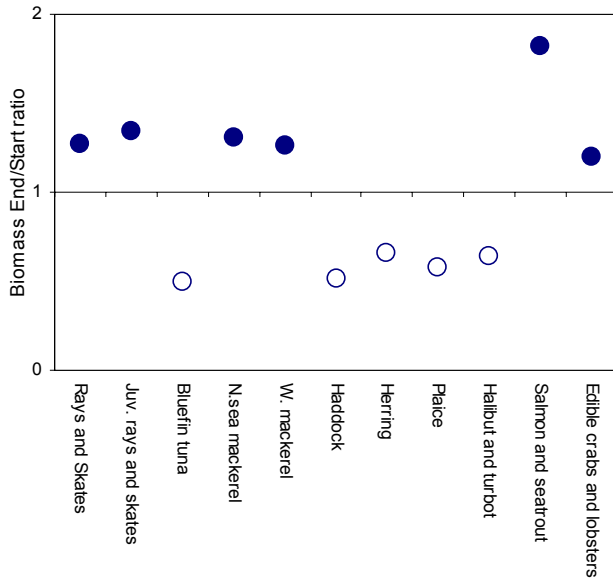

(b) Social maximisation

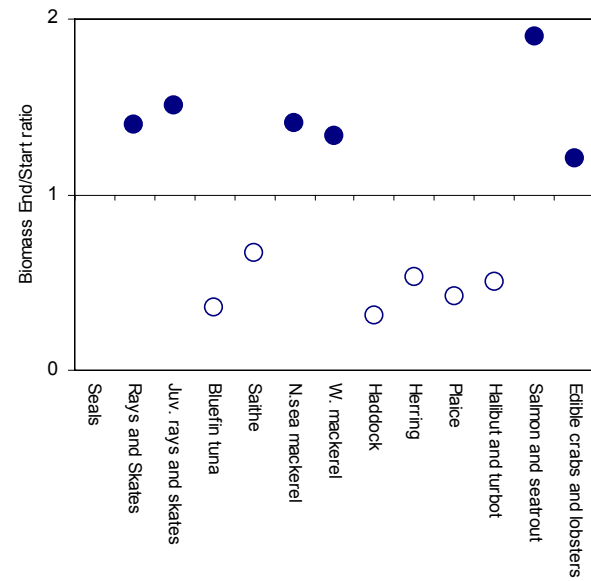

(c) Ecological maximisation

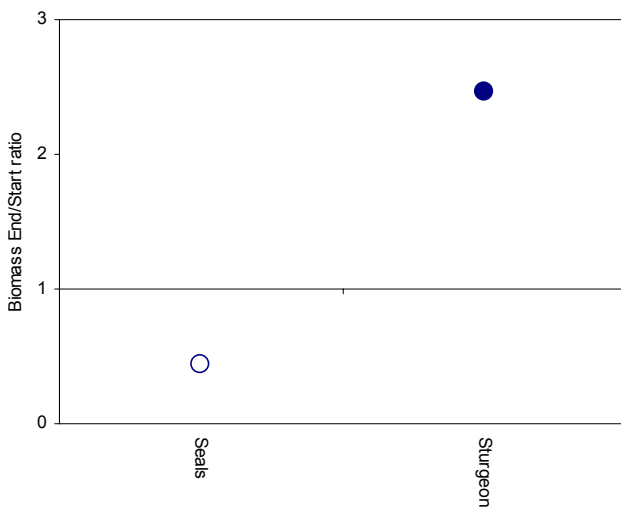

(d) Big compromise

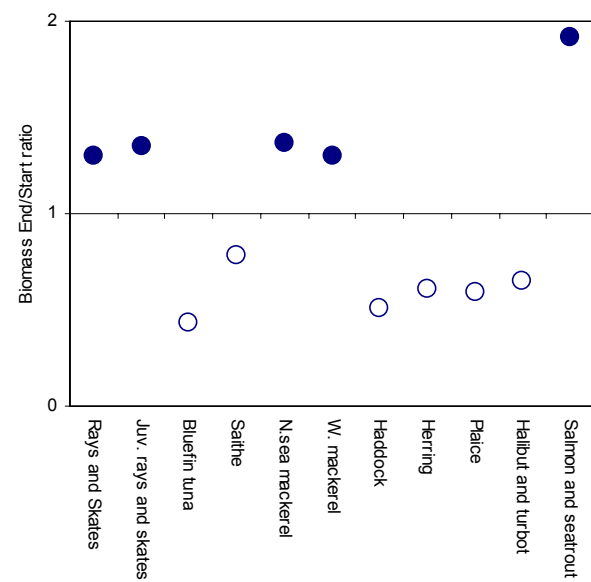

**Figure 7.** Winners (dots) and losers (open circles) from each policy scenario. Note that only those groups whose biomass changed  $\pm 20\%$  from are displayed

to a measure of ‘ecological stability’ is in question. Also questionable is whether ‘ecological stability’ is an appropriate goal, since ecosystems are under constant change. For myself, a goal of stability conjures up the argument between Conservation vs. Preservation. From a semantics point of view, I prefer the term ecosystem integrity, even though we are left with no better way to measure it.

Furthermore, the issue of ecological importance is not easily resolved since its interpretation changes from place to place and with changing attitudes. For example, seals were once considered

pests, but more recently are valued as indicators of ecosystem health. At present, the only ‘rule’ that users should perhaps adopt regarding assumptions relating to ecological importance, is to ensure that they are explicit about the settings chosen; the rationale and the consequences (sensitivity to) their choices.

Comparison is made (Table 4) with the subjective settings vs. ecological importance defined as  $1/(P/B)$  (meaning that larger slowing growing species are given higher importance) suggested during the workshop (see Appendix 1, Table iii).

There were no large unexpected differences in the fishing strategy when ecological importance was defined as 1/(P/B). However, on re-running the search procedure on the original subjective weight scenario, alternative F estimates of 0.9, 0.4, 1.1, 0.9, 0.8 were obtained. It is thus concluded that little can be said with confidence on the effects of changes in the assumption on ecological importance settings since the variation resulting from different F estimates from search procedure are greater than the differences between the assumptions on ecological importance

One noticeable difference relating to different assumptions on ecological importance was the open loop scoring value for ecological stability. Under the subjective weighting the value was -142, whilst under the 1/(P/B) weighting it was -1264. It is not clear how this result occurs but it is presumed to be related to the combination of the higher importance weight and lower fishing pressure assigned to seals.

*Scenario 4: The ‘Big Compromise’*

Once again, the big compromise policy scenario came up with a fishing strategy (and consequent effects on species) similar in pattern to the economic and social scenarios (Fig 7d). Although fishing pressure is increased on herring and ‘prime’ species, concurrent fishing on their predators mitigates the fishing effects. In fact, some of the prime species showed small increases in abundance over the period. Total system biomass declines by 11% and value by 35%.

*Comparisons between policies*

The overviews of system responses given above show some consistency in the general prediction of a harvest strategy that targets predators of high

**Table 5.** Comparison of open loop scores for each policy outputs for each scenario. Shaded boxes are highest scores.

Criteria	Policies				
	Status Quo	Economic max	Social max	Ecological	‘Big compromise’
Economic	22.56	115.4	110.4	15.82	118.61
Social	27.79	1057.06	1139.75	116.28	1109.13
Ecosystem	-0.9	-288.09	-299.2	-142	-272.69
Overall	1.5	3.42	5.03	-0.3	7.85

value (economic or social) species, so as to relieve them from predation and allow increased fishing mortality. It emphasises clearly a competition between fisheries and natural predators both exploiting a common resource.

Since jobs and value are closely related it is no surprise that the economic and social scenarios are similar. The ecological scenario is in stark contrast to the others and is the only scenario that manages to achieve a higher biomass and value of the fishery over the 20 simulation period. Results from the big compromise are more closely aligned with the economic and social values. The trade-offs between policy weightings are explored further below. Economic, social and ecosystem scores for each policy (Table 5) reveal that while maximum social and ecological benefit was derived under the appropriate policies, the greatest economic benefit was not predicted under the economic scenario. The reason for this is not known, but may be in part related to small differences resulting from the search procedure as previously discussed. The greatest overall score was derived from the ‘Big Compromise’, this being 6 times that of the status quo.

Trade-offs between policy options in which each objective is given a positive weight are explored for a variety of scenarios A-G (Table 6). Increasing the weight on ecosystem stability (A-D) results in lowering the overall score for the policy, even though economic and social scores are considerably increased. Curiously, the ecosystem criteria score does not show any consistent direc-

**Table 6.** Comparison of various policy trade-offs according to different weightings (A-G).

POLICY	A	B	C	D	E	F	G
<i>Policy weighting tradeoffs</i>							
Net economic value	1	1	1	1	5	5	1
Social (employment) value	1	1	1	1	5	1	5
Ecosystem stability	1	2	5	10	1	1	1
<i>F estimates</i>							
Drifters	9.2	9	8.3	9.4	9.3	8.9	9.3
Trawlers and liners	7.3	7.3	7.1	6.7	7.9	7.5	7.7
Others	2.8	1	1.6	20.1	27.9	21.7	1.2
Pots	1.3	1	0.7	0.7	5.7	1.7	1
Seal killing	0.9	0.7	1.3	0.6	0.3	0.3	0.9
<i>Criteria scores</i>							
Economic	118.61	114.64	116.9	147.61	149.16	148.75	113.27
Social	1109.13	1086.42	1073.71	1259.31	1288.15	1268.93	1095.99
Ecosystem	-272.69	-274.08	-268.5	-281.67	-296.62	-288.32	-278.73
Overall	7.85	7.05	5.41	4.07	49.94	27.07	26.97

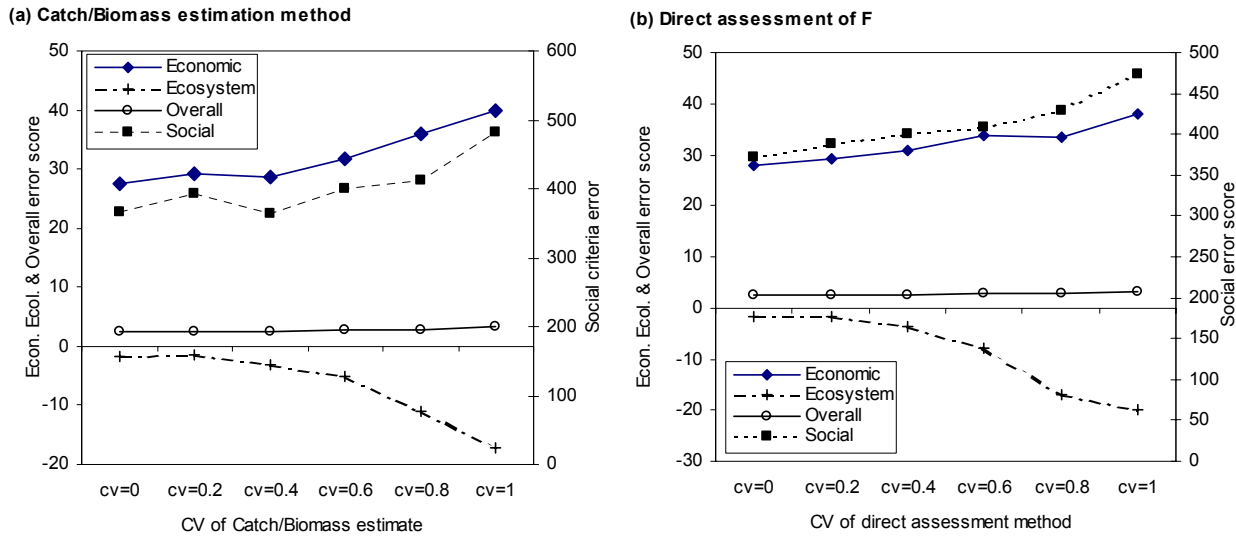

**Figure 8.** Error scores for policy evaluation criteria resulting from changes in uncertainty for two fishing mortality assessment methods.

tional change when more emphasis is given to that policy. Policies E-G in which higher weight is given to economic and or social objectives score much higher overall than policies with ecological objectives. A counter-intuitive result is the higher score for social criteria under policy D (ecosystem biased) as opposed to policy G (social biased). Ranking most highly overall is Policy E. Its equal heavy weight to socio-economic objectives results in the lowest ecosystem score, but highest economic and social scores.

Though the arbitrary scores allow ranking of the policies they do not offer clear direction for advice, nor can they be expected to. One reason is because of the large inherent uncertainties involved in subjective valuations of weightings of ecological importance for each group. A second is the result of variations in the estimations of optimum F derived from the search procedure. Finally, it is not clear whether maximising the total overall score of the criteria is indeed an appropriate goal. The meaning and interpretations of the scores appear to be context sensitive. It necessarily begs the questions as to whether a higher overall score is obviously better or just higher?

One important point to note from this exercise, is that it seems that the results of the policy trade-offs, in the case of this model, are least sensitive to changes in the weighting on ecosystem stability. Perhaps it is more sensitive to values assigned to relative ecological importance and Bideal/Binitial for each group?

*Considering the effects of management error:*

*closed loop scenarios*

All previous results were based on the assumption that managers have perfect information (open loop simulations) and are able to implement the harvest strategies without error. Closed loop simulations, whereby a simulated manager tries to implement a harvest strategy, were used to examine some of the effects of potential errors on the implementation of harvest strategies. Those considered were management errors relating to (i) the use of alternative assessment methods for predicting F and used for updating harvest tactics and, (ii) increases in catchability resulting from changes in fleet efficiency. All closed loop simulation are run using the 'Big Compromise' policy scenario (i.e. equal weighting to economic, social and ecological stability).

*Comparison of uncertainty of assessment methods*

Figure 8 examines the errors associated with increasing variation in the reliability of 2 assessment methods. The error score for each policy evaluation criteria is calculated as the difference in the criteria score between open loop simulations (manager with perfect information) and closed loop simulations (manager with assessment errors) over a range of variation coefficients in the accuracy of the assessments (CV's). The initial large errors represent the change from assuming fisheries are managed with perfect information to one where errors occur (open loop to closed loop simulations). The same pattern of errors occurs for both assessment methods. Increasing uncertainty in the F estimate (increasing

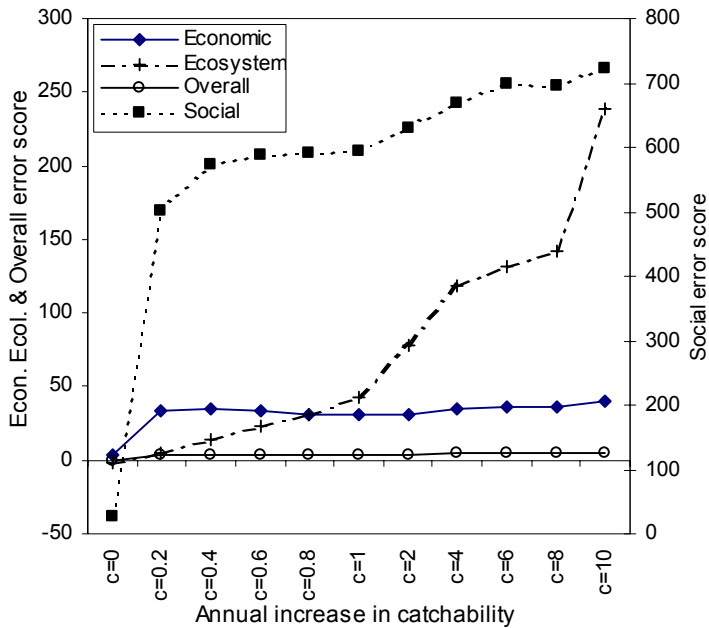

**Figure 9.** Error scores for policy evaluation criteria resulting from changes in catchability

CV's) results in increasing error scores. It is interesting to note, that for both assessment methods, the error score relating to ecosystem stability is only slightly affected by the initial 20% increase in variation, and further rises result in increasingly larger errors.

*Effects of increasing fleet efficiency*

The change in error scores associated with annual increases in catchability are most marked between zero and 0.2 and up to 0.4. (Fig 9). i.e. even a small change in gear efficiency has a large impact on the implementation of the harvest strategy. Beyond annual increases in catchability of 0.4, the impact of changes in efficiency still occur but are apparently less dramatic. Being unaware as to what reasonable values for annual changes in catchability might be, I examined changes up to 10 fold. Even these more severe increases did not have such an impact as the initial increase from zero to 0.2.

**Discussion**

My overall impression is that the policy evaluation options in Ecopath with Ecosim have contributed great utility to the software. Users wishing to examine various policy options can now compare them with a degree of objectivity by using the criteria scores, and also examine responses of specific groups within the ecosystem.

However, although the evaluation criteria scores allow ranking of the policies they do not offer clear direction for advice, nor can they be ex-

pected to, since subjective valuations together with variations resulting from technical procedures and differences in interpretation compound the already complex results. It is likely that only local knowledge of issues can help interpret what to do. Familiarity with the model and the various issues are paramount. I am sure that it would not be prudent to take a model from an unfamiliar area and suggest to make predictions about the 'best' harvest policies.

It is unavoidable that any comparison of policy options will require very careful sensitivity testing to the range of possible input parameters used during simulations. This is simply a consequence of the fact that while it is recognised that many of the parameters are clearly important, we do not in many cases have good ideas of what the parameter values should be. Personally, I found that the complexity in understanding the effects of various input parameters was instructive by forcing me to think in greater detail about interactions in the modelled ecosystem. Potential users should make sure not to just accept the default settings for parameters, but explore further the consequences of changing them. One of the most important parameters to examine the effects of, as stated by Carl Walters and Villy Christensen, is the flow control (=vulnerability). Users should not overlook the importance of the need to examine trends in temporal dynamics (rather than simple comparisons of condition at the start and the end of simulations), and should ensure that values of the parameters used are reported with any simulations, since small changes to them may drastically alter results.

**Comments on the methodology**

1. All policy simulations are dependent on the results of the search procedure. The method used does not always seem to provide consistency in its results under the same conditions, thus it is imperative to examine thoroughly the effects of various options for the search procedure. Sometimes the procedure seems to converge to more than 2, quite different solutions. A general rule given by Carl Walters is that values of relative F above 20 are nonsense, so perhaps it is best to run the search again until better values are found. If no values are found, perhaps the scenario should be abandoned.
2. It remains unclear to me how changes in flow control affect fishing, since fishing mortality is not directly linked with the flow control parameter.
3. The question of the ecological importance settings remains to be resolved as to its interpretation. There was some confusion amongst those at the workshop. Using 1/(P/B) as a representation of the relative impor-

tance of species implies that slower growing longer lived individuals are intrinsically more important. Several workshop participants felt that this was perhaps a better representation of ecological stability.

4. Simulation results generally made sense. A common result from simulations aimed at maximising socio-economic value of some fisheries was to fish hard on predators of highly valued species (in terms of money or job creation), thus removing a source of competition to the fishery.

5. Sometimes counter-intuitive results occurred - e.g. the maximum economic value was not derived from the economic maximisation scenario. Others curious results, not easily explained, occurred in the examination of policy trade-offs.

6. Little can be said with confidence on the effects of changes in the assumption on ecological importance settings since the variation resulting from different F estimates from the search procedure are greater than the differences between the assumptions on ecological importance.

7. Results of the policy trade-offs, in the case of this model, are least sensitive to changes in the weighting on ecosystem stability.

8. The close loop simulated manager is another good addition, with the ability to examine the effects of changes in uncertainty associated with assessments and fishing efficiency. During closed loop simulations, increasing uncertainty with assessment methods produced increases in error scores for evaluation criteria. For the ecological stability criteria, the change in error was small initially and increased with increasing uncertainty of the assessment.

9. During closed loop simulations, the effects of annual changes in catchability were most pronounced for initial small changes from zero to 0.4.

10. As previously mentioned in the workshop, it would be helpful to see a measure of the variability resulting from closed loop simulations.

## References

Christensen, V. 1995. A model of trophic interactions in the North Sea in 1981, the year of the Stomach. *Dana* 11(1): 1-28.

Holdsworth, E.W.H. 1874. Deep sea fishing and fishing boats: an account of the practical working of the various fisheries around the British Isles. Edward Stanford, 6,7, & 8, Charing Cross, S.W. London. 429 pp.

Mackinson, S. 2000. Representing trophic interactions in the North Sea in the 1880s, using the Ecopath mass-balance approach. Draft technical report. 82 pages. Fisheries Centre, Vancouver, Canada.

## Appendices

**Appendix Table (i).** Standard run settings.

Duration of simulation (years)	20
Integration steps (per year)	100
Relaxation parameter [0,1]	0.5
Discount rate (% per year)	4
Equilibrium step size	0.003
Equilibrium max. fishing rate (relative)	3
Number of time steps for averaging results	5
Discount rate	0.04

**Appendix Table (ii)** Social settings.

Gear type	Crew size	Jobs/Catch
Drifters	14	7
Trawlers and liners	9	4.5
Others	6	3
Pots	3	1.5
Seal killing	2	1

**Appendix Table (iii)** Ecological settings.

Biomass Group	B ideal / B base	Import. Weight Subject.	Impor. Weight 1/(P/B)	Trophic Level	Vuln. (prop.T)
Cetaceans	2	1	50.0	4.2	0.42
Seals	1	0	16.7	4.8	0.48
Seabirds	1	1	2.5	4.7	0.47
Sharks	1	0	6.7	4.3	0.43
Juv. sharks	1	0	3.3	4.3	0.43
Rays and Skates	1	0	3.1	4	0.4
Juv. rays and skates	1	0	1.6	4	0.4
Bluefin tuna	1.5	1	2.9	4.6	0.46
Sturgeon	2	1	9.1	4	0.4
Cod	1.5	1	2.0	4.4	0.44
Juv. cod	1.5	1	1.0	3.9	0.39
Whiting	1	0	1.2	4.4	0.44
Juv. whiting	1	0	0.6	4.1	0.41
Saithe	1	0	1.7	4.5	0.45
Juv. saithe	1	0	0.7	4.2	0.42
N.Sea mackerel	1	0	1.1	3.9	0.39
Westn. mackerel	1	0	1.1	3.9	0.39
Haddock	1	1	1.0	4	0.4
Juv. haddock	1	1	0.6	3.8	0.38
Herring	1	1	0.8	3.4	0.34
Sprat	1	0	0.7	3.3	0.33
Norway pout	1	0	0.5	3.5	0.35
Sandeel	1	0	0.4	3.4	0.34
Plaice	2	1	1.5	3.7	0.37
Sole	2	1	1.6	3.6	0.36
Brill	2	1	2.3	3.8	0.38
Halibut and turbot	2	1	3.7	4.6	0.46
Horse mackerel	1	0	1.4	4	0.4
Salmon and seatrout	1.5	1	1.3	4	0.4
Gurnards	1	0	0.7	4	0.4
Other predatory fish	1	0	0.9	4.3	0.43
Other prey fish	1	0	1.3	3.8	0.38
Cephalopods	1	0	0.3	3.6	0.36
Zooplankton	1	0	0.1	2.1	0.21
Euphasiids	1	0	0.2	2.8	0.28
Ed' crabs & lobsters	2	1	0.3	3.8	0.38
Other crustaceans	1	0	0.3	2.6	0.26
Echinoderms	1	0	0.3	3.4	0.34
Polychaetes	1	0	0.3	2.5	0.25
Other macrobenthos	1	0	0.3	2.9	0.29
Meiofauna	1	0	0.1	2.3	0.23
Benthic microflora	1	0	0.0	1.6	0.16
P'tonic microflora	1	0	0.0	1.6	0.16
Phytoplankton	1	0	0.0	1	0.1

# Ecosim Case Study: Port Phillip Bay, Australia

**Beth Fulton and Tony Smith**  
CSIRO Marine Research, Hobart

## Abstract

Port Phillip Bay is a large shallow, semi-enclosed marine embayment adjacent to the city of Melbourne, in southeast Australia. The bay is exploited both recreationally and commercially and between 1992 and 1996 was the subject of a large-scale study encompassing research and monitoring in the fields of physical oceanography, toxicants, algal nutrients, marine ecology and ecological modelling. Information from this study (in particular for the year 94-95) was used to construct and parameterise an Ecopath model of the system.

Across the many vulnerability and policy options evaluated using this Ecopath with Ecosim model, three characteristic system states were found, which corresponded with three possible policy objectives. These states can be summarised by the state of the shark component of the model. When economic objectives were dominant, sharks were removed from the system; when there was a compromise between economic and ecological objectives, sharks persisted at current levels; and when ecological objectives were dominant, sharks increased in abundance. This consistent response suggests that, in this case, sharks may be a good indicator species. However, the relative insensitivity to alternative policy settings of other groups, primarily those in

the lower trophic levels of the model, suggests that they may not be good indicator species for the effects of fishing. Lastly, it was clear that the criteria used to determine management objectives must be carefully considered, as economic and social objectives may lead to substantial restructuring of ecosystems unless they are balanced with some ecological reference points. Similarly, conservation and public pressure to preserve charismatic species may not lead to balanced ecosystems either. Some measure of importance must be given to all groups in the system if a balanced, ecologically robust system is to be achieved.

## General Introduction

Port Phillip Bay (PPB) is a large shallow marine embayment adjacent to the city of Melbourne. The bay is approximately 1930 km<sup>2</sup> in area and is 26m at its deepest, though over half of it is less than 8m deep. Its catchment is home to over 3 million people (16% of the total Australian population) and as a consequence Port Phillip Bay is exploited both recreationally and commercially.

The commercial fishery takes between 700 and 2000t of finfish from the bay every year, which includes 60 species and has a total wholesale value of about AUD\$3 million. This is low relative to other Australian bays (adjusting for size), but invertebrate fisheries more than make up for the difference. Currently 600t of cultured mussels

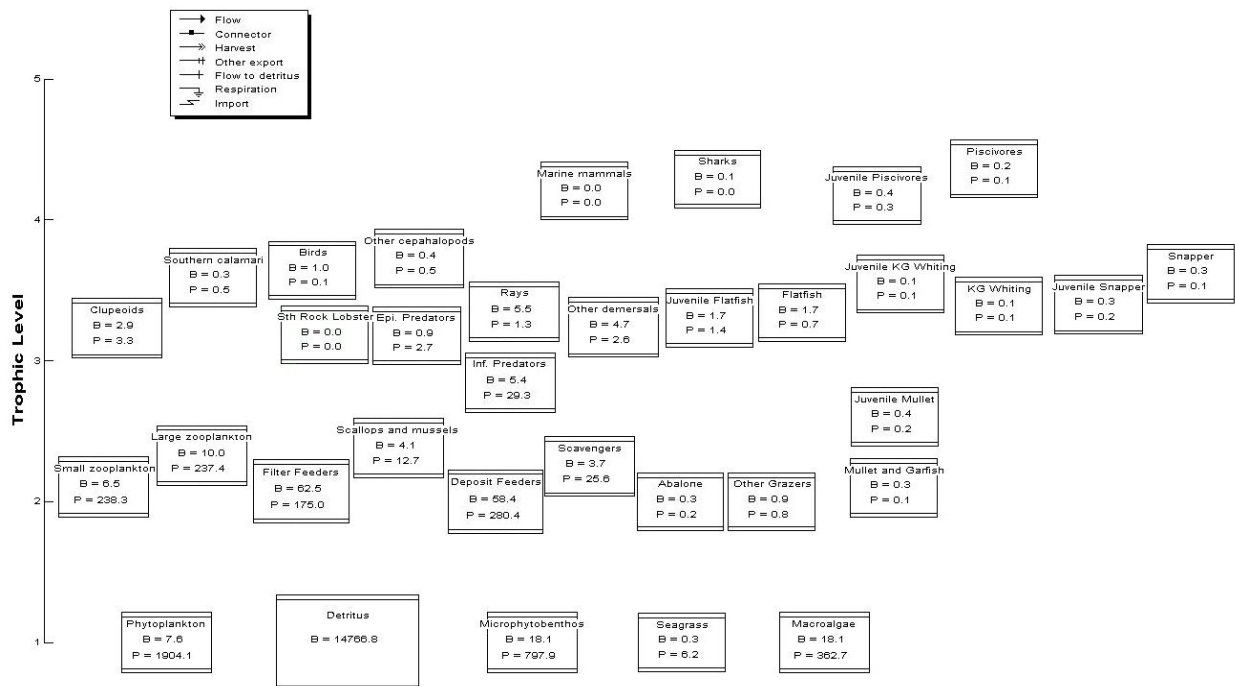

**Figure 1.** Schematic representing the various groups in the Port Phillip Bay Ecopath model, their relative biomasses and trophic levels. Boxes which are larger contain more biomass, trophic level is given by the axis on the left. Actual flows, such as that due to consumption, are omitted here for clarity.

and 50t of wild abalone are harvested annually (worth AUD\$1.5 and \$1 million respectively) and these dominate the invertebrate catch contribution. Until recently scallops were also harvested quite intensively, bringing in up to 10000t (shell weight), but that fishery is now closed. The recreational fishery is thought to land about 470t of fish a year (effort is estimated at about 670,000 angler hours per year).

A large study of the bay, the Port Phillip Bay Environmental Study (PPBES), was undertaken between 1992 and 1996. This study encompassed research and monitoring in the fields of physical oceanography, toxicants, algal nutrients, marine ecology and ecological modelling (Harris et al 1996). Information from this study was used to construct the Ecopath model discussed here. In particular the year 94-95 was used to parameterise the model, as that was the time when there was the greatest amount of information overlap for the various components. It was necessary to use data from years either side to complete the information in a few cases.

### The ECOPATH model for the Bay

The pools and settings for the PPB Ecopath model are summarized in Table 1 and the flow diagram in Figure 1 (and the model can be found on the Ecopath website). The PPB model appears to include more detail at lower trophic levels than many other current Ecopath models. Where possible, information was taken from the technical reports published for the PPBES.

It was necessary during the model balancing phase to move some estimates to the edge of the ranges quoted in the reports, but no estimate was moved beyond those ranges. All calculations were initially done using nitrogen as the unit of biomass (mg N m<sup>-3</sup>), which was then converted to tonnes (wet weight)/km<sup>2</sup> using the assumption that wet weight = 100\*N and the volume of PPB is 2.6809\*e<sup>10</sup> m<sup>3</sup>.

Where possible, groups were split so that cannibalism was less than 1% of predation. This was not possible for the zooplankton due to a lack of information, nor was it possible for the lumped piscivore group (cohort splitting did reduce it substantially but not completely). Thus these groups continued to have cannibalism > 5%. The most uncertain biomass values are for the benthic invertebrate groups. Unfortunately they are also among the largest pools.

Seven fishing fleets were included in the Ecopath model, including purse seine, scallop dredge, haul

seine, longline, mesh nets, hand (diving) and pot. The aquaculture of mussels is also included. No costs were built in due to a lack of information. The fishery information is summarized in Table 2.

A mediation effect was included in the Ecosim model to reflect the importance of seagrass to juvenile King George Whiting. Careful attention was paid to whether or not the mediation made the model any more likely to fall into chaotic or oscillatory behaviour, there was no evidence that it did. An Ecospace model of PPB was also developed, with eight habitats (Corio, Geelong Arm, High nutrient, Shallow, Intermediate, Central mud, Swan Bay and Sands), and an advection set calculated with a Coriolis parameter of -0.5. Results from this model are not reported here. Unless noted below or in the tables, all parameter settings were as of the Ecosim defaults.

### Results of policy evaluations

Policies were evaluated over a 30 year time frame, starting from the base Ecopath year of 1995. The social and ecological criteria used are given in Tables 3 and 4 respectively, and the results of the policy analyses are summarized in Table 5. There are few differences between the economic and social strategies, due to the absence of costs, and so the results below are summarized only for the economic strategy.

**Table 3.** Social weightings used

Gear Type	Jobs/Catch
Purse seine	1
Scallop Dredge	1
Haul seine	1
Longline	0.5
Mesh nets	1
Dive	0.2
Aquaculture	0.1
Pots	0.5

Under the original vulnerability settings (a default value of 0.3 for all groups), most groups are stable under status quo Fs, except for King George whiting, which declines. Using estimates of the state of the various fished groups relative to their virgin levels of egg production, the vulnerabilities were tuned to more reasonable values. Most groups ended up with a vulnerability of 0.5, though scallops, abalone, clupeoids and both the piscivore age classes were lower (0.48, 0.45, 0.45, 0.4 and 0.4 respectively). Southern rock lobster, juvenile snapper, marine mammals and both age groups of King George Whiting were higher (0.8, 0.6, 0.9, 0.8 and 0.8 respectively). With these vulnerability settings, all groups were at a stable equilibrium (no mean increase or decrease) under status quo Fs.

**Table 1.** Ecopath groups and settings. Note all values shown are the final (balanced) values used. Notes on changes made during balancing refer to those made to the original values to achieve the values shown here. Also note the original P/B and Q/B for pilchards were halved and all those for all other fish (juvenile snapper down to Rays) were quartered during balancing. TS = Trawl scalar (multiplier of trawl survey catch to get final biomass estimate – to take into account trawl efficiency).

Group name	Habitat area	B (t/km <sup>2</sup> )	P/B (/yr)	Q/B (/yr)	Unassim Q	EE*	P/Q*	Catch (t/km <sup>2</sup> /yr)	Discards (t/km <sup>2</sup> /yr)	Notes	References
Phytoplankton	1	7.617	250	-	-	0.604	-	0	0	Lumped all phytoplankton. Increased P/B by 15% in balancing.	Murray and Parslow, 1997
Small zooplankton	1	6.477	36.8	59.781	0.3	0.713	0.616	0	0	Zooflagellates and small copepods. Increased Q/B by 32% in balancing.	Beattie et al 1996 (Q/B, B) Holloway and Jenkins 1993 (P/B).
Large zooplankton	1	9.974	23.8	38.609	0.3	0.866	0.616	0	0	Mesozooplankton. Increased Q/B by 32% in balancing.	Beattie et al 1996 (Q/B, B) Holloway and Jenkins 1993 (P/B)
Deposit Feeders	0.835	69.948	4.8	66.7	0.3	0.73	0.072	0	0	Decreased B by 40% during balancing (otherwise needed HUGE detritus import)	Poore 1992 Wilson et al 1993
Scallops and mussels	0.835	4.922	3.1	10.9	0.3	0.25	0.284	0.862	0.25	Wild scallops and cultured mussels. Reduced by 10% during balancing.	Kailola et al 1993 Poore 1992
Filter Feeders	0.85	73.511	2.8	11.8	0.3	0.756	0.237	0	0.025	Non commercial filter feeders (including oysters). Decreased by 35% during balancing.	Poore 1992 Wilson et al 1993
Infaunal Predators	0.4	13.575	5.4	58.4	0.2	0.999	0.092	0	0	Burrowing worms mainly. Reduced by 20% in balancing	As above
Epifaunal Predators	0.4	2.363	2.9	21.9	0.2	0.978	0.132	0	0.026	Crustaceans, gastropods and starfish. Reduced by 10% during balancing.	As above
Sth Rock Lobster	0.37	0.068	0.73	12.41	0.2	0.874	0.059	0.003	0	Reduced by 2% during balancing.	Anon 1996 Wilson et al 1993
Abalone	0.37	0.699	0.73	12.41	0.3	0.994	0.059	0.048	0	Green and black lip. Reduced by 2% during balancing.	Anon 1996 Poore 1992 Wilson et al 1993
Other Grazers	0.4	2.249	0.88	11.68	0.3	0.758	0.075	0	0	Urchins the only species of this lumped group actually fished. Reduced by 10% during balancing	Anon 1996 Kailola et al 1993 Poore 1992 Wilson et al 1993
Scavengers	0.4	9.326	6.86	55.48	0.25	0.834	0.124	0	0	Reduced by 10% during balancing	Poore 1992 Wilson et al 1993
Microphytobenthos	1	18.135	44	-	-	0.14	-	0	0	P/B increased by 25% during balancing	Murray and Parslow 1997
Seagrass	0.1	2.591	24	-	-	0.345	-	0	0.01	P/B increased by 25% during balancing	Murray and Parslow 1997
Macroalgae	0.7	25.907	20	-	-	0.301	-	0	0.01	P/B increased by 25% during balancing	Murray and Parslow 1997
Clupeoids	1	2.85	1.15	30.15	0.2	0.993	0.038	0.812	0	Pilchards, anchovy and sprat.	Anon 1996 Hall 1992 Parry et al 1995



Table 1. continued.

Group name	Habitat area	B (t/km <sup>2</sup> )	P/B (/yr)	Q/B (/yr)	Unassim Q	EE*	P/Q*	Catch (t/km <sup>2</sup> /yr)	Discards (t/km <sup>2</sup> /yr)	Notes	References
Juvenile Snapper	0.7	0.469	0.548	2.737	0.2	0.973	0.2	0.012	0	<3 yrs. VBGF k = 0.1079, Wavg/Wk = 1.16	Officer and Parry 1996 Parry et al 1995
Snapper	0.7	0.376	0.493	2.737	0.2	0.785	0.18	0.033	0.001	3+ Split (for all split fish groups) based on recruitment to fishery and 50% maturity	Gunthorpe et al 1997 As above
Juvenile Flatfish	0.75	2.319	0.821	2.737	0.2	0.977	0.3	0.004	0.001	<3 yrs. VBGF k = 0.19, Wavg/Wk = 1.2	As above
Flatfish	0.75	2.285	0.411	2.737	0.2	0.902	0.15	0.143	0.011	3+	As above
Juvenile KG Whiting	0.8	0.142	0.821	2.737	0.2	0.936	0.3	0.06	0	<3 yrs. VBGF k = 0.16, Wavg/Wk = 1.1. TS = 5	As above
KG Whiting	0.8	0.117	0.548	2.737	0.2	0.293	0.2	0.001	0	3+ TS = 5	As above
Juvenile Piscivores	0.72	0.567	0.821	2.737	0.2	0.999	0.3	0	0	<3 yrs. VBGF k = 0.42, Wavg/Wk = 1.1. TS = 20	As above
Piscivores	0.72	0.288	0.411	2.737	0.2	0.92	0.15	0.001	0	3+ To get B used demersal trawl data and TS = 20	As above
Juvenile Mullet	0.825	0.526	0.411	2.737	0.3	0.993	0.15	0	0	<3 yrs. VBGF k = 0.271, Wavg/Wk = 1.15. TS = 4.45	As above
Mullet and Garfish	0.825	0.383	0.329	2.737	0.3	0.909	0.12	0.053	0	3+. To get B used demersal trawl data and TS = 4.45	As above
Other demersals	0.965	4.899	0.548	2.737	0.2	0.849	0.2	0.041	0	All other demersal finfish. TS = 2	As above
Southern calamari	0.93	0.319	1.825	18.25	0.2	0.785	0.1	0.05	0	TS = 4	Officer and Parry 1996 Parry et al 1995
Other cephalopods	0.945	0.415	1.369	9.125	0.2	0.952	0.15	0	0	Octopus. TS = 4	Gunthorpe et al 1997 Lee 1994 As above
Rays	0.9	6.166	0.234	1.56	0.2	0.007	0.15	0	0		Officer and Parry 1996 Parry et al 1995
Sharks	0.62	0.148	0.234	1.56	0.2	0.639	0.15	0.002	0.001	To get B used demersal trawl data, TS = 13-35.	Gunthorpe et al 1997 Schmid et al 1993. As above
Birds	1	1.018	0.07	1.69	0.2	0.145	0.041	0	0	Based on representative densities of shorebirds in similar habitats elsewhere in the world and map of PPP bird habitat.	Briggs et al 1987 Pices 1998
Marine mammals	1	0.02	0.09	19.88	0.2	0.006	0.005	0	0	Dolphins and seals	Dolphin Research Institute 2000
Detritus	1	14766.84	-	-	-	0.994	-	0	0	398.96 t imported per yr. Biomass represents top 20cm of sediment.	Nicholson et al 1996 Harris et al 1996

**Table 2** Fishery settings and information: background Fishery Information and History. Blanks do not represent zeros, but lack of information.

Fishery	Commercial Catch and Effort (% Vic/Aust catches)	Recreational Catch	Commercial Annual Value (AUD)	Socioeconomic Importance	Fishing Method and Management (LML = legal min length)	History
Abalone	34 – 92t live weight taken annually (mean 52t) = 5% Vic	2% of commercial catch	\$650,000 - \$1,700,000	Economically very important, due to high value, high licence/ processing fees. Poaching = problem.	Divers on Hookah off small boats. 34 commercial licences for the zone including PPB (licence limitation began in 1968) and ITQ. Recreational divers have a 10 abalone per day bag limit. LML = 10cm.	Fishery began 1962. 1968 licences and LML introduced. 1984 licence reduction scheme (2 for 1)
Anchovies	16 – 138t (mean 73t) = 40% Vic = 40% Aust.		\$19,000 - \$209,000		Purse seine (alternate/ incidental target for pilchard fishery). 118 commercial licences.	Fishery was highest during 1970s but had dropped by 50% by the end of the 80s (unknown cause, maybe heavy fishing)
Barracouta	1 – 5t (mean 2.65t) = 20% Vic		\$1,000 - \$4,200			
Blue Mussel	600 – 650t (cultured on ropes)	Small amount of wild stock (used as bait)	\$1,500,000		20 aquaculture entitlements for the bay. 3 commercial diver licences for the bay (dredging banned now but used to bring in up to 1000t)	Farming began in 1984.
Flathead	24 – 171t	240t +	\$40,000 - \$58,000	Socially very important as is one of the main targets of the rec fishery, not as important commercially.	Mesh nets. 118 commercial licences. Recreational fishers need a licence, but the number of these is unlimited.	Peaked in 1950s (at about 171t) dropped to 50t by late 1980s and now about 25t (market now prefers other table fish)
Flounder	7 – 20t (mean 13t) = 44% Vic = 17% Aust		\$34,000 - \$101,000		118 commercial licences. Bycatch species of scallop dredge fishery too.	
Garfish	37 – 58t (mean 52t) = 34% Vic = 4% Aust	18t	\$162,000 - \$226,000		Haul seines. 118 commercial licences.	
King George Whiting	47 – 130t (mean 69.5t) = 35% Vic = 6% Aust	62t	\$526,000 - \$857,000	One of the most important commercial species in PPP.		Fishery began 1960s. Currently listed as stable there is concern as to stock health.
Other Cephalopods	0.2 – 0.5t		\$6000 - \$8000	Bait fishery really		Incidental catch of haul seines and dredges
Other Finfish	79 – 269t	51t	\$163,000 - \$655,000		Haul seines. 118 commercial licences. Bag limit of 20 fish if recreational. LML = 27cmTL	Haul seines, purse seines, longlines and mesh nets

Table 2. continued.

Fishery	Commercial Catch and Effort (% Vic/Aust catches)	Recreational Catch	Commercial Annual Value (AUD)	Socioeconomic Importance	Fishing Method and Management (LML = legal min length)	History
Pilchard	324 – 2058t (mean 1347t) = 62% Vic = 14% Aust	Small (most bait actually purchased from commercial catches)	\$465,000 - \$2,278,000	Largest finfish fishery, but demand is really dictated by the petfood and tuna farm industries	Purse seines. 18 commercial licences.	Mean catch 1970s – early 1980s was about 325t (increasing trend). Substantial kill in 1995.
Rock Lobster	4 – 5t		\$100,000 - \$150,000		Potting season closed June – November. Pots must have escape slots. Recreational fishers can only take 4 per person per day. LML = 105/ 110 mm (female/male)	Began 1900s. 1950s seasonal fishery. 1958 LML put on, seasonal closures started. 1968 fixed entry scheme. 1971 bag limit for rec. 1980s entitlements reduced.
Scallops	540 – 10450t live weight (meat weight *6.5) = 75% Vic		\$1,000,000 - \$15,000,000	Was very important fishery as was the largest invertebrate fishery before it was closed. Some aquaculture has now started.	Dredging (now closed), with 18 PPB and 66 dual (PPB/Vic) waters licences. Recreational bag limit of 100 per day. No strict LML but fishery closes when >20% catch <70mm (now happening more often). Longlines, usually bycatch of snapper fishery. 118 commercial licences.	Dredge fishery began 1963. Crashed in 1969. Recovered and crashed again in 1989-1990. VERY variable.
Shark	4 – 22t		\$69,000 - \$91,000			
Snapper	41 – 319t = 78% Vic = 2% Aust	10t	\$345,000 - \$1,174,000+	Of decreasing importance as not as economically attractive or efficient as other fisheries (lines are stripped by rec fishers with GPS) so fishers are aging out of fisheries without replacement (thus effort has dropped)	Longlines. Gear, effort, season and area restrictions in place. LML = 27cm	Began 1843. Licences and LML intro 1915. LML at current level 1926. Declined early 1950s. Beach seining dropped out in 1970s when more and more input control introduced.
Southern Calamari	17 – 63t = 48% Vic	78 – 130t	\$83,000 - \$246,000			Decreasing trend since 1960s (unknown whether decline of effort or stock)
Sprat	2 – 74t		\$2,000 - \$95,000			
Urchins	0.3 – 0.8t		\$500			
Yellow-eye Mullet	30 – 86t (mean 46.5t) = 24% Vic = 8% Aust	11t	\$31,000 - \$94,000			

**Table 4.** Ecological weightings used.

Group	Charismatic		Strategies Equal		B/P	
	Bideal/B	Import- ance	Bideal/B	Import- ance	Bideal/B	Import- ance
Phytoplankton	1	0	1	1	2	0.004
Small zooplankton	1	0	1.5	1	2	0.027
Large zooplankton	1	0	1.5	1	2	0.042
Deposit Feeders	1	0	1.5	1	2	0.208
Scallops and mussels	1	0	5	1	2	0.323
Filter Feeders	1	0	1	1	2	0.357
Inf. Predators	1	0	1	1	2	0.185
Epi. Predators	1	0	2	1	2	0.345
Sth Rock Lobster	1	0	5	1	2	1.37
Abalone	1	0	3	1	2	1.37
Other Grazers	1	0	1.5	1	2	1.137
Scavengers	1	0	1	1	2	0.146
Microphytobenthos	1	0	1	1	2	0.023
Seagrass	1	1	1	1	2	0.042
Macroalgae	1	0	1	1	2	0.05
Clupeoids	1	0	2	1	2	0.87
Juvenile Snapper	1	0	1	1	2	1.825
Snapper	4	0.1	4	1	2	2.028
Juvenile Flatfish	1	0	1	1	2	1.218
Flatfish	1	0	2	1	2	2.433
Juvenile KG Whiting	1	0	1	1	2	1.218
KG Whiting	5	0.1	5	1	2	1.825
Juvenile Piscivores	1	0	1	1	2	1.218
Piscivores	1	0	3	1	2	2.433
Juvenile Mullet	1	0	1	1	2	2.433
Mullet and Garfish	1	0	2	1	2	3.04
Other demersals	1	0	2	1	2	1.82
Southern calamari	1	0	2	1	2	0.548
Other cephalopods	1	0	1.5	1	2	0.73
Rays	1	0.1	1	1	2	4.274
Sharks	2	1	2	1	2	4.274
Birds	3	1	3	1	2	14.286
Marine mammals	4	1	4	1	2	11.111

When forced by historical time series of F, the Ecosim predictions matched historical time series of population fluctuations well. These vulnerability settings were then used through out the policy analysis discussed here – except for a sensitivity analysis the results of which will be briefly described below.

Under the economic strategy (Figure 2), Fs are increased for most fisheries, except for the pot (rock lobster) fishery. The most notable increase is for the mesh net fishery, which results in the commercial extinction of sharks and flatfish. These are predators of other fished species, the latter generally having higher commercial value. Marine mammals decline to about two thirds of their biomass under status quo fishing, while scallops decline to about half. Of the non-fished groups, epifaunal biomass shows a notable increase, while piscivores decline.

The ecosystem strategy (Figure 3) results in lower Fs for all fisheries except the dive (abalone) fishery. This in turn results in increases in most

groups, except abalone. The reason for the increased fishing on abalone is not yet understood. In contrast with the economic strategy, the sharks in particular show a major increase, and the flatfish are steady. The marine mammals more than double their biomass relative to that under the economic strategy. These improvements in biomass are at the expense of reductions in total value of catch to about 20% of those under the economic strategy.

In trying to find a compromise between economic and ecological objectives, it was necessary to give ecological objectives a higher weighting than those of economics to have any apparent impact upon the outcome. There was no smooth transition in effects as the weights varied from heavily ecological to economic; rather there was a two step jump. With the ecological weighting set to 1, the first jump occurs at an economic weighting of 0.5 (see compromise strategy in Table 5). This outcome is very similar in form to the economic solution

(Figure 4) except that flatfish are not reduced as much, while sharks and mammals are not depressed at all, and snapper is allowed to increase rather than decrease. The second jump is straight to the full economic solution. This jump occurs quite suddenly at an economic weight of 0.71. At this point there are two equally strong minima in the objective function, one corresponding to the economic solution and the other to the intermediate (first step) solution (see flip point strategy in Table 5).

To assess the impact of the vulnerability settings on the conclusions, the policy analysis was repeated under three sets of vulnerabilities. The first set was a blanket 0.2 for all groups, except the snappers, which had to be reduced to 0.01 to achieve long term stability. The second set was a blanket 0.7 for all groups. The final set scaled vulnerabilities with trophic level (starting with the lowest groups having  $v = 0.1$  and increasing with trophic level up to marine mammals which had a  $v = 0.95$ ).

**Table 5.** Results of policy optimisations. There were two equally strong minima at the flip point so both are reported here for that strategy weighting. *Status quo* and F at 64 have no weightings reported in the table as they were sketched out in Ecosim and then just run through the closed loop without first using an open loop optimisation. The Ratio of End/Start values gives the relative change in catch over the 30 year period by dividing the catch at the beginning of year 0 by the catch at the end of year 30. The qualitative responses are given for those groups which showed some change under the various policies, but aren't primary fishing target species. Flat indicates that the trace for the species moved straight across and showed no trend away from equilibrium. A "+" indicates the species trace showed an increase with time (the more +s the greater the increase). A "-" indicates the species trace showed a decrease with time (the more -s the greater the decrease). "Oscillate" indicates that the species trace followed periodic fluctuations (like those of a stable limit cycle).

	Strategy					Flip point (min1/min2)	F at 64	B/P
	<i>Status Quo</i>	Economic	Social	Ecosystem	Compr- omise			
<i>Weighting</i>								
Economic	-	1	0.0001	0.0001	0.5	0.71	-	0.0001
Social	-	0.0001	1	0.0001	0.5	0.71	-	0.0001
Ecosystem	-	0.0001	0.0001	1	1	1	-	1
<i>Objective Function</i>								
Economic	163.76	300.13	299.00	63.74	222.89	222.35 / 256.52	60.90	110.83
Social	163.76	233.16	233.71	46.29	163.33	163.41 / 197.44	60.90	67.94
Ecosystem	0.00	-609.50	-620.85	-390.74	-449.91	-467.89 / -518.21	-548.57	-1442.36
<i>Estimated Relative Fs</i>								
Purse seine	1	2.6	2.8	0.3	2	2.0 / 1.9	64	0.2
Scallop Dredge	1	2.9	2.8	0.8	3	3.1 / 3.0	64	0.8
Haul seine	1	0.8	0.9	0	0.4	0.5 / 0.6	64	0.5
Longline	1	1.9	2.8	0.1	0.3	1.0 / 0.5	64	0.2
Mesh nets	1	20.8	20.1	0.3	2.1	1.8 / 20.1	64	0.2
Dive	1	1.3	1.2	2.6	1.3	1.2 / 1.3	64	0.5
Pots	1	0.6	0.9	1.2	0.6	1.0 / 0.7	64	0.5
<i>Overall Average</i>								
Total Catch	849.28	1457	1447.8	479.63	1215.12	1805.63 / 1947.98	1789.02	525.41
Total Value	1222177	1877457	1878475	546499.3	133755	1481459 / 1892616	632218	818937.1
<i>Ratio End/Start</i>								
Total Biomass	1	0.74	0.73	1.09	0.89	0.99 / 0.87	0.75	1.06
Mammal Biomass	0.98	0.66	0.61	1.41	1.15	1.1 / 0.72	0.001	1.16
Shark Biomass	0.97	0	0	1.9	1.1	1.04 / 0	0.116	1.2
Shark Catch	0.97	0	0	1.53	0.27	1.02 / 0	0	1.21
King George Whiting B	0.77	1.99	1.85	3.93	2.87	2.83 / 1.55	0	2.78
King George Whiting C	0.77	2.67	1.46	0	0.62	2.83 / 1.6	0	2.78
Snapper Biomass	1.01	0.83	0.48	1.09	1.63	1.01 / 1.18	0	0.78
Snapper Catch	1.01	0.82	0.4	0.79	0.44	1.01 / 1.18	0	0.78
Flatfish Biomass	1.01	0	0	1.07	0.64	0.74 / 0	0	0.94
Flatfish Catch	1.01	0	0	0.88	0.16	0.73 / 0	0	0.95
Abalone Biomass	0.95	0.79	0.99	0.01	0.69	0.87 / 1.07	0	1.05
Abalone Catch	0.95	0.98	0.56	0.01	0.17	0.87 / 1.05	0	1.05
Clupeoid Biomass	1	0.79	0.79	1.25	0.83	1.01 / 1.07	0	1.21
Clupeoid Catch	1	0.59	0.68	1.02	0.18	1.01 / 1.06	0	1.22
Scallop Biomass	1	0.52	0.51	1.15	0.67	1 / 0.95	0	1.11
Scallop Catch	1	0.74	0.62	1.01	0.19	1 / 0.96	0	1.13
<i>Qualitative Responses</i>								
Zooplankton Biomass	flat	+	+	-	-	+ / flat	+++	-
Piscivore Biomass	flat	--	--	+	+	-- / --	oscillate	+
Other demersal Bmass	flat	-	-	-	flat	flat / -	oscillate	-
Epifaunal Biomass	flat	++	++	-	flat	flat / ++	oscillate	-

Under an economic objective, the results are relatively insensitive to the vulnerability setting, though there are some changes in the King George Whiting, Southern Rock lobster and Snapper from case to case. The one exception is the blanket  $v=0.7$  case, where the outcome more closely resembles the original ecological outcome. Using the ecological objective, the results are far more variable between the different vulnerability

settings. The behaviour of Scallops and Mussels, Abalone, Southern Calamari, Cephalopods and Snapper is particularly affected. However, the overall results are consistent across vulnerabilities, the greatest difference being for  $v=0.2$  which produced a more "intuitive" answer. In this case, the increase in the biomass of "charismatic" species did not come at the expense of the elimination of other "unimportant" species, but rather all species were maintained at acceptable levels.

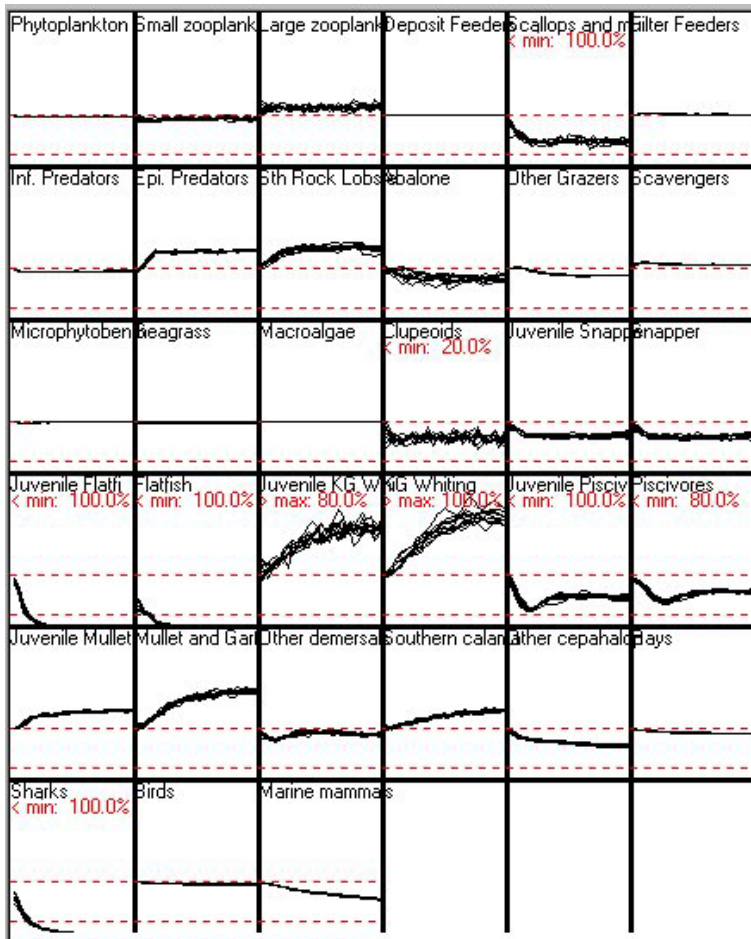

**Figure 2** – Biomass through time plots for the optimisation under primarily economic objective.

The conclusions from the sensitivity analyses are that the general policy analysis is fairly robust across vulnerability settings in this case, though the “standard economic solution” disappears at higher vulnerabilities. Furthermore, it is worth noting that oscillating output is very likely if the majority of the vulnerabilities are set at either extreme. At the lower end vulnerabilities it is really only an artifact of a mismatch in the numerical scheme used and the mean of the oscillations is trustworthy. At the higher end though it is the result of chaotic dynamics and is thus often uninterpretable.

As with vulnerabilities, policy outcomes seem relatively insensitive to minor changes in the various ecological importance criteria. It was found that abalone are no longer eliminated when some importance is placed on its retention in the system.

One notable feature of the PPB Ecosim model is the relative lack of responsiveness at lower trophic levels. This contrasts with other trophic models being developed for the PPB system. To

test whether such responsiveness could be “forced” within Ecosim, one scenario examined the consequences of increasing the Fs on all fisheries to 64 times their current levels. Not surprisingly, all the fish groups were rapidly depleted, but there was still very little response in the lower trophic levels. This may be due to the amount of “leeway” in the EE values for the primary producers in the system (as little as 0.6), as they are feeding the dominant detrital foodweb rather than the classic, primary producer based, foodweb in this system. The introduction of a dummy fleet that fishes zooplankton and detritivores detritivores could allow some exploration of this issue.

### Discussion

For the Port Phillip Bay model examined in this study, there are three characteristic system responses corresponding to three possible policy objectives. These can be best summarized using the sharks as an indicator species:

1. Economic objectives are dominant: sharks are removed from the system;
2. Compromise of economic and ecological objectives: sharks persist at current levels;
3. Ecological objectives are dominant: sharks allowed to increase.

The fact that these results are so consistent across parameter settings, and that most of the ancillary groups are so unresponsive under the different objectives, highlights a few interesting points.

The first of these is that in this study sharks act as a very good indicator species for both system response and policy objectives. Choice of ecological indicators has become a very important topic recently. Identifying a species or group that is sensitive to system changes and which is a useful measure of policy performance would prove very useful, both within model studies and in field monitoring.

The second point raised by the results of the policy analysis is that the modelled system is fairly insensitive, with some pools showing no change even under extreme changes, such as F at 64 times current levels. This suggests either that the model itself is insensitive to change, and that some structural exploration may be of use, and/or that the system itself is robust to change as it is

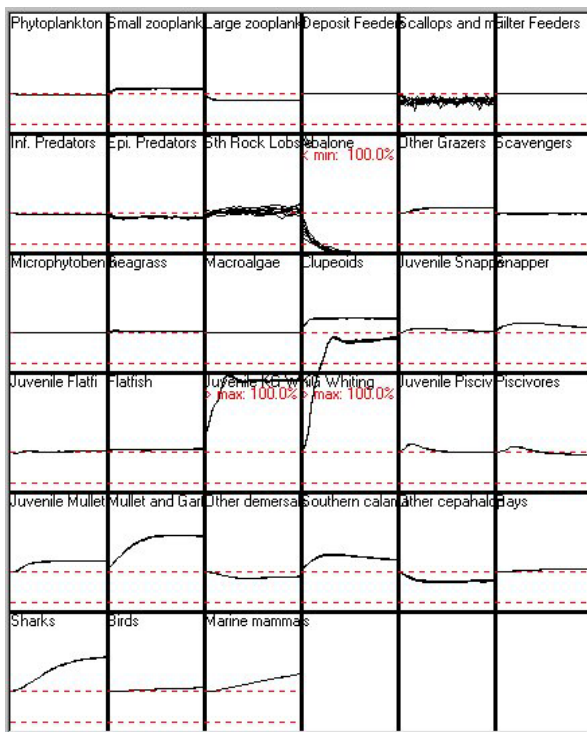

**Figure 3** – Biomass through time plots for the optimisation under primarily ecological objective.

built primarily upon a detritus based foodweb rather than a classical web. Simulations from another dynamic model program suggest that Port Phillip Bay is much more strongly affected by eutrophication than by fishing, and this may explain and support the insensitivity of the lower trophic groups in the Ecosim simulations run here. Either way, more research into the form and basis of the foodwebs in Port Phillip Bay, especially the pelagic ones, would be instructive in evaluating how well the Bay might cope with increasing pressures.

Lastly, an important cautionary note. The lack of cost data for the fisheries meant that the economic objectives really only used the value of the fisheries to determine the outcome. The inclusion of reliable and realistic cost data may well see different or at least a wider range of results and is an exercise that will be completed in the near future.

### General conclusions

Vulnerabilities are one of the most crucial elements of Ecosim and their potential effect on policy evaluations can not be neglected. Ecosim's best performance (with regard to matching reality) is most often seen when higher trophic levels or heavily depleted groups have high prey vulnerabilities and lower trophic levels have vulnerabilities in the range 0.4 to 0.5. Furthermore, even though vul-

nerabilities generally had little qualitative effect on the overall outcome of the policy evaluations in this case, it was apparent that the choice of vulnerability settings may prove to be crucial in other circumstances and so must be given a good deal of attention. For instance if we had been concerned more with a particular species, say abalone, rather than the system as a whole then vulnerabilities and their effect on policy evaluation may have had a much more striking impact here.

The criteria used to determine management objectives must also be carefully considered. Economic and social objectives may lead to radical restructuring of ecosystems unless they are balanced with some ecological reference points. However, conservation and public pressure to preserve charismatic species may not, in fact probably will not, lead to balanced ecosystems. Some measure of importance must be given to all groups in the system if a balanced, ecologically robust system is to result from management policy implementation.

### References

Anon, 1996. Catch and Effort Information Bulletin 1995. Conservation and Natural Resources: Victorian Fisheries Research Institute: Queenscliff, Victoria, Australia.  
 Beattie, G., A. Redden and R. Royle 1996. Microzooplankton Grazing on Phytoplankton in Port Phillip

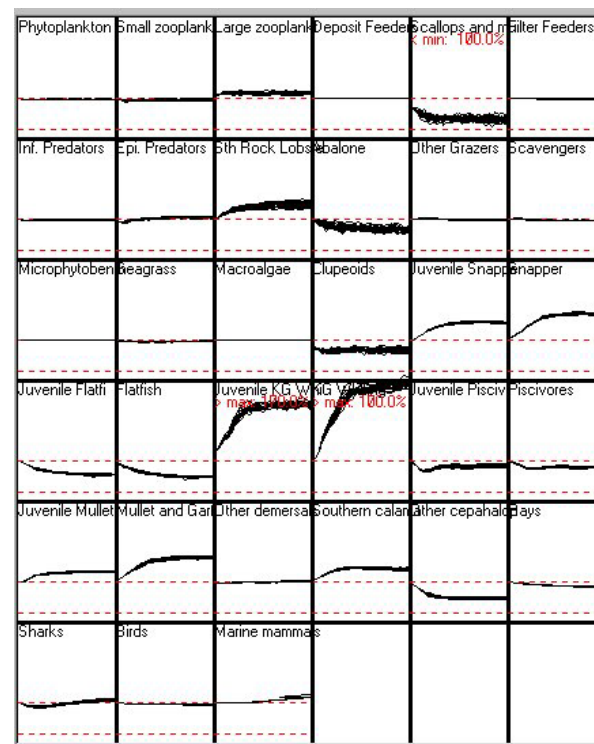

**Figure 4** – Biomass through time plots for the compromise, or first step change, optimisation

- Bay. Technical Report No. 31. Port Phillip Bay Environmental Study. CSIRO: Canberra, Australia.
- Briggs, K.T., W.B. Tyler, D.B. Lewis, D.B. and D.R. Carlson 1987. Bird Communities at Sea off California: 1975-1983. *Studies in Avian Biology*. 11.
- Dolphin Research Institute 2000. Dolphin Education Project Question and Answers. Dolphin Research Institute: Frankston, Victoria, Australia. Also available at <http://www.dolphinresearch.org.au/institute.html>
- Gunthorpe, L., P. Hamer and S. Walker 1997. Bays and Inlets Scalefish Fisheries Review: Volume 1: Life cycles and habitat requirements of selected Victorian fish species, including an assessment of the main habitat threatening processes and recommendations for habitat maintenance, rehabilitation and enhancement. Marine and Freshwater Resources Institute: Queenscliff, Victoria, Australia.
- Hall, D.N. (ed), 1992. Port Phillip Bay Environmental Study: Status Review. Technical Report No. 9. Port Phillip Bay Environmental Study. CSIRO: Canberra, Australia.
- Harris, G., G. Batley, D. Fox, D. Hall, P. Jernakoff, R. Molloy, A. Murray, B. Newell, J. Parslow, G. Skyring and S. Walker 1996. Port Phillip Bay Environmental Study Final Report. CSIRO: Canberra, Australia.
- Holloway, M., and G. Jenkins 1993. The Role of Zooplankton in Nitrogen and Carbon Cycling in Port Phillip Bay. Technical Report No. 11. Port Phillip Bay Environmental Study. CSIRO: Canberra, Australia.
- Kailola, P.J., M.J. Williams, P.C. Stewart, R.E. Reichelt, A. McNee and C. Grieve 1993. Australian Fisheries Resources. Bureau of Resource Sciences, Department of Primary Industries and Energy and the Fisheries Research and Development Corporation: Canberra, Australia.
- Lee, P.G. 1994. Nutrition of Cephalopods: Fueling the System. *Marine Behaviour and Physiology*. 25 (1-3): 35-51.
- Murray, A., and J. Parslow 1997. Port Phillip Bay Integrated Model: Final Report. Technical Report No. 44. Port Phillip Bay Environmental Study. CSIRO: Canberra, Australia.
- Nicholson, G.J., A.R. Longmore and R.A. Cowdell 1996. Nutrient Status of the Sediments of Port Phillip Bay. Technical Report No. 26. Port Phillip Bay Environmental Study. CSIRO: Canberra, Australia.
- Officer, R.A., and G.D. Parry 1996. Food Webs of Demersal Fish in Port Phillip Bay. Technical Report No. 36. Port Phillip Bay Environmental Study. CSIRO: Canberra, Australia.
- Parry, G.D., D.K. Hobday, D.R. Currie, R.A. Officer and A.S. Gason. The Distribution, Abundance and Diets of Demersal Fish in Port Phillip Bay. Technical Report No. 21. Port Phillip Bay Environmental Study. CSIRO: Canberra, Australia.
- PICES Working Group 11 1998. Consumption of Marine Resources by Marine Birds and Mammals in the PICES Region. 1998 Report of Working Group 11. Sidney, Canada. Also available at <http://pices.ios.bc.ca/wg/wgf.htm>.
- Poore, G.C.B. 1992. Soft-bottom macrobenthos of Port Phillip Bay: a literature review. Technical Report No. 2. Port Phillip Bay Environmental Study. CSIRO: Canberra, Australia.
- Schmid, T. H., F.L. Murru and F. McDonald 1993. Feeding habits and growth rates of bull (*Carcharinas leucas*), sandbar (*Carcharinas plumbeus*), sandtiger (*Eugomphodus taurus*), and nurse (*Ginglymostoma cirratum*) sharks. *Journal of Aquaculture and Aquatic Sciences* 5(4): 100-105.
- Wilson, R.S., B. F. Cohen and G.C.B. Poore 1993. The Role of Suspension-feeding and Deposit-feeding Benthic Macroinvertebrates in Nutrient Cycling in Port Phillip Bay. Technical Report No. 10. Port Phillip Bay Environmental Study. CSIRO: Canberra, Australia.
-



## Simulating extreme fishing polices in Prince William Sound, Alaska: a preliminary evaluation of an ecosystem-based policy analysis tool

Thomas A. Okey  
Fisheries Centre, UBC

### Abstract

The biotic assemblage of Prince William Sound, Alaska has changed considerably during the last 35 years in response to the great Alaskan earthquake, oceanographic changes, fisheries activities, the Exxon Valdez oil spill, and other factors. The multifactorial nature of the mechanisms of change in this system make it challenging to discern their relative importance when attempting to understand troublesome trends. The management of fisheries stands out, however, as a way of shaping the state of living marine resources because fisheries are controllable and they influence biotic assemblages. A new dynamic simulation tool in Ecosim with Ecosim enables comparisons of various fishing policy scenarios in a whole food web context according to different weightings of 'economic,' 'social' (employment), and 'ecological' considerations. A simplistic exercise in which a policy compromise was developed from three extreme polices—corresponding with optimization of these three objectives—enabled comparison of the findings among systems featured in this volume. Optimization of short-term economic goals and social (employment) goals in Prince William Sound led to simulated fishing strategies that caused direct, fishery-imposed extinction of top predators (e.g., pinnipeds, Pacific halibut, and lingcod), resulting in increases in biomasses of two gadoid species (Pacific cod and sablefish), and thus the overall monetary and employment value of the system. Such a strategy of imposing extinctions to optimize short-term economic or employment value is generally illegal, though perhaps operational in some systems throughout the world. Optimization of ecological considerations led to fishing scenarios that increased porpoise, pinnipeds, orcas, seabirds, and other high trophic level predators, while correspondingly decreasing the same two gadoid species. The potential importance of direct take of pinnipeds, as well as food competition between fisheries and other high trophic level species, is indicated by positive responses of these groups to decreases in fishing, though this simulated response does not imply that other sources of stress and mortality are unimportant to apex predators. The numerical stability of pinnipeds (the chosen assessment endpoint) was achieved by weighting the ecological considerations by a factor of 3.2 over economic and social considerations. Predicted reductions in catches by subsistence, recreational, and commercial fisheries by the end of all 20 year simulations were thought to be a function of discounting the future during the policy search procedure through initially-aggressive value optimization, though it may also be an indication that current fishing exceeds sustainable lev-

els in an ecosystem context. Predicted catch reductions associated with the weighted compromise were not considerably different than catch reductions associated with other options.

---

### Introduction

Prince William Sound (PWS) is a coastal marine embayment situated at the northern apex of the Gulf of Alaska, north of latitude 60° (longitude 146° W). Its area covers just over 9,000 km<sup>2</sup>, or approximately 15 San Francisco Bay units. The ecological uniqueness of Prince William Sound is due largely to the interplay of its physical characteristics with the climatic and oceanographic characteristics of the region. Warm moist air arriving from the south becomes trapped, uplifted, and cooled by the surrounding Chugach Mountains, releasing considerable precipitation. Annual rainfall ranges from 160 to 440 cm in PWS, and snowfall can reach 2290 cm in the surrounding mountains (Michelson 1989 *in* Wheelwright 1994). Rain runoff and snowmelt enter from myriad streams, but icebergs and glacial melt also contribute fresh water. Yet greater amounts of fresh water enter PWS as a stratified lens aloft an incurrent of marine water at the Hinchbrook entrance. Numerous rivers and glaciers feed this freshwater lens as it is transported alongshore by the Alaska coastal current from as far south as British Columbia (Wheelwright 1994). Complex estuarine gradients and interfaces are present.

The Sound's highly variable depths (800 m maximum and 300 m mean; Cooney 1993, Loughlin 1994) relate to its origins as a submerged section of the formidable Chugach Mountains, which surround and frame it. The habitats of the sound are relatively isolated from the Gulf of Alaska by barrier islands and two relatively narrow channels. Its coastline is very convoluted, and in many places it drops off steeply just beyond a narrow shelf. Other parts of the sound contain extensive shallow areas, and still others drop vertically as the subaerial walls of fjords.

Although organisms inhabiting Prince William Sound are reasonably typical of sub-polar coastal marine environments, the biotic community is shaped by the ecosystem's unique physical attributes. Examples include protection from outer coast wind and waves, estuarine gradients, islands and heterogeneous coastlines, large intertidal zones (e.g., diurnal tide range at Cordova = 3.8 m; NOAA 1984), rocky habitats, mudflats, cobble beaches, steep and short spawning streams, fjords and their associated glaciers and turbidity gradients, and extreme physical season-

ality. All of these combine to produce a unique and productive environment for diverse assemblages of marine mammals, birds, invertebrates, fishes, plants, and microorganisms. Longer-term climatic oscillations have also influenced the abundances of some species in the region, such as salmon (NRC 1996, Mantua *et al.* 1997).

Humans began interacting with the biota of the Prince William Sound ecosystem approximately 10-15 thousand years ago, soon after crossing the Bering Strait (Dumond and Bland 1995). The ecological influence of these first residents of the region is not well known, though they likely collected clams from the intertidal and shallow areas, salmon from the many streams and rivers (Cooley 1961), marine mammals (e.g., Simenstad *et al.* 1978), and other fishes, invertebrates, seabirds, and marine algae. The first modern impacts to the region's marine ecosystem came over two centuries ago when Russian traders and furriers hunted the newly discovered Steller's sea cow (*Hydrodamalis gigas*) to biological extinction and the sea otter (*Enhydra lutris*) to ecological extinction. The removal of the sea otter undoubtedly triggered considerable changes in nearshore zones, as this species is known to exert strong keystone effects throughout its still expanding range (Estes and Palmisano 1974, Estes *et al.* 1974, Dayton 1975, Simenstad *et al.* 1978, Kvitek *et al.* 1992, Estes and Duggins 1995). The ecological changes caused by the extinction of the Steller's Sea Cow will remain in the realm of speculation (e.g. Pitcher 1998).

Although the activities of 20<sup>th</sup> century Alaskan fishing industries are reasonably well recorded, their broader ecological effects are poorly known, as the complexity of these ecosystems prevented our understanding of whole food web dynamics. Industrial whaling targeted baleen whales between 1845 to 1966, but much of the whale biomass was removed in the final years of that fishery. It has been suggested that the removal of a large proportion of the baleen whales in Alaskan waters triggered cascading effects such as increases in gadoid fish (e.g., through a release in foraging competition between juvenile pollock and whales; see NRC 1996). Offshore foreign fleets removed considerable proportions of Pacific herring populations from Alaskan waters during the first three decades after WW-II. Catches peaked in 1970 at over 140,000 t-year<sup>-1</sup>, then quickly declined by an order of magnitude (Jacobson *et al.* 1999). Pacific herring shows signs of gradual recovery in all Alaskan regions except for Prince William Sound where runs failed to return four years after the Exxon Valdez oil spill. Pacific herring is of primary commercial importance in

PWS, and it is an important forage fish for higher trophic levels. Slope rockfish, particularly Pacific Ocean perch, were likewise heavily exploited in the Gulf of Alaska region during the 1960s. They remain at low levels, but are said to be responding to conservative management (Low *et al.* 1999).

Major changes have occurred in the PWS ecosystem during the last 20 years. Red king crab and shrimp populations collapsed, and their fisheries were closed with no signs of recovery (Reeves and Turnock 1999); pinnipeds, including harbor seals and sealions have declined steadily (e.g., Frost *et al.* 1998); and some seabirds, such as common murre, cormorants, and black legged cormorants have declined—all since the early 1980s (EVOS 2000). In contrast, fish species such as Pacific cod, walleye pollock, and flatfish have increased considerably in the region during this same time period. Alaskan groundfish fisheries are fully utilized and overcapitalized, and the associated by-catch of king crabs, shrimp, herring, and snow crabs may hinder the recovery or the resilience of these formerly abundant species (Low *et al.* 1999). All species of salmon have increased considerably during this time period. Although several salmon hatcheries in Prince William Sound contribute to a large proportion of the pink salmon captured in the local fisheries, increased adult survival in the Alaska Gyre is the most likely reason for the record salmon runs in recent years (Wertheimer 1997, Heard and Anderson 1999). The notion that shifting oceanographic conditions in the region strongly influences the region's marine community structure and is associated with some of the observed changes now holds considerable weight (Hollowed and Wooster 1992, Brodeur *et al.* 1996, Piatt and Anderson 1996, Tyler and Kruse 1996, Francis *et al.* 1998, Rosenkrantz 1999).

Fisheries can, nevertheless, exacerbate climate-driven fluctuations by changing the resiliencies of populations to natural disturbance or stress (*sensu* Holling 1973, Sousa 1984). Insight into these influences can be gained by examining the potential forcing caused by fisheries in a system-wide, interaction-web context. Furthermore, evidence is continuing to mount that high trophic level predators, such as mammals and birds, can be adversely affected by intensive fisheries at lower trophic levels (e.g., Mackinson *et al.* 1997, Springer and Speckman 1997). Trites and his colleagues (1997), on the other hand, suggest that competition for food by fisheries does not generally have important detrimental effects on marine mammals, based on evidence that diet overlap is small between fisheries and marine mammals. The relative importance of such competition and

**Table 1.** Basic input parameters and detritus fate for the Prince William Sound model, 1994-1996. TL = trophic level calculated by *Ecopath*; OI = omnivory index indicating the degree of omnivory; P/B = production/biomass; Q/B = consumption/biomass; EE = ecotrophic efficiency, expressing the proportion of the production lost to export or predation. Detritus fate is a percentage allocation of the remaining production between detritus pools. (Nekton fall = dead carcasses to sea floor.) Values in italics/light shading were calculated by *Ecopath*; other values are empirically-based input estimates, contributed by a collaboration of experts on PWS (Okey and Pauly 1999a).

Group	Trophic level	OI	Biomass (t·km <sup>-2</sup> )	P/B (year <sup>-1</sup> )	Q/B (year <sup>-1</sup> )	EE	Detritus fate (%)			
							Nekton fall	In-shore	Off-shore	Export
Transient Orca	5.4	0.01	0.001	0.05	6.04	0	1	-	50	49
Resident Orca	4.9	0.21	0.015	0.05	8.67	0	1	-	50	49
Sharks	4.5	0.98	0.662	0.10	7.00	0.753	1	-	99	-
Halibut	4.5	0.36	0.677	0.32	1.73	0.865	1	-	99	-
Porpoise	4.5	0.20	0.015	0.24	29.20	0.989	1	30	69	-
Pinnipeds	4.4	0.15	0.072	0.06	25.55	0.994	1	30	69	-
Lingcod	4.3	0.35	0.077	0.58	3.30	0.816	-	40	60	-
Sablefish	4.0	0.87	0.293	0.57	6.42	0.774	-	-	100	-
Adult flounder	4.2	0.12	4.000	0.22	3.03	0.792	-	-	100	-
Adult salmon	4.2	0.05	3.410	1.31	13.00	0.996	-	30	-	70
Pacific cod	4.1	0.47	0.300	1.20	4.00	0.936	-	-	100	-
Juv flounder	4.0	0.12	0.855	0.22	3.03	0.956	-	-	100	-
Avian raptors	3.9	2.07	0.002	0.05	36.50	0.000	-	25	-	75
Seabirds	3.8	0.54	0.022	0.17	150.60	0.976	-	40	40	20
Deep demersals	3.8	0.80	0.960	0.93	3.21	0.984	-	-	100	-
Pollock 1+	3.8	0.24	7.480	0.71	2.56	0.998	-	-	100	-
Rockfish	3.7	0.26	1.016	0.17	3.44	0.969	-	20	80	-
Baleen whales	3.7	0.16	0.149	0.05	10.90	0	1	-	99	-
Juv. salmon	3.5	0.31	0.072	3.91	62.80	0.969	-	30	70	-
Nearshore demersal	3.3	0.24	4.200	1.00	4.24	0.776	-	100	-	-
Squid	3.3	0.01	3.000	3.00	15.00	0.940	-	-	100	-
Eulachon	3.2	0.63	0.371	5.00	18.00	0.991	-	40	20	40
Sea otters	3.2	0.18	0.045	0.13	117.00	0.005	-	50	50	-
Deep epibenthos	3.2	0.62	30.00	3.00	10.00	0.961	-	-	100	-
Capelin	3.1	0.02	0.367	3.50	18.00	0.999	-	50	30	20
Adult herring	3.1	0.01	2.810	1.54	18.00	0.962	-	-	100	-
Pollock o	3.1	0.01	0.110	2.34	16.18	0.945	-	50	50	-
Shal large epibenth.	3.1	0.03	3.100	2.10	10.00	0.750	-	80	20	-
Sea ducks	3.1	0.00	0.005	0.20	450.50	0	-	40	40	20
Sandlance	3.1	0.01	0.595	2.00	18.00	0.946	-	50	50	-
Juv. herring	3.0	0.01	13.406	0.73	18.00	0.985	-	30	70	-
Jellies	3.0	0.11	6.390	8.82	29.41	0.004	-	10	90	-
Deep small infauna	2.3	0.23	49.400	3.00	23.00	0.916	-	-	100	-
Near omni-zoo	2.3	0.19	0.105	7.90	26.33	0.982	-	70	30	-
Omni-zooplank	2.3	0.19	24.635	11.06	22.13	0.979	-	10	90	-
Shal small infauna	2.2	0.18	51.500	3.80	23.00	0.941	-	100	-	-
Meiofauna	2.1	0.11	4.475	4.50	22.50	0.950	-	20	80	-
Deep large infauna	2.1	0.09	28.350	0.60	23.00	0.931	-	-	100	-
Shal small epibent	2.1	0.05	26.100	2.30	10.00	0.976	-	70	30	-
Shal large infauna	2.0	0.00	12.500	0.60	23.00	0.520	-	100	-	-
Near herbi-zoo	2.0	0.00	0.136	27.00	90.00	0.978	-	70	30	-
Herbi-zooplankt	2.0	0.00	30.00	24.00	50.00	0.976	-	10	90	-
Nearshore phytopl	1.0	0.00	5.326	190.00	-	0.950	-	70	30	-
Offshore phytopl	1.0	0.00	10.672	190.00	-	0.950	-	10	90	-
Macroalgae & grass	1.0	0.00	125.250	4.00	-	0.135	-	50	50	-
Nekton falls	1.0	0.21	2.000	-	-	0.953	-	80	20	-
Nearshore detritus	1.0	0.30	19.520	-	-	0.542	-	-	100	-
Offshore detritus	1.0	0.46	114.480	-	-	0.587	-	-	-	100

detrimental effects undoubtedly varies among ecological setting, and this question has far-reaching implications for both fisheries and marine biota. There is also no question that designing policy and analyses around the question of human-nonhuman competition will be constrained by conservation laws and subsistence-

rights laws.

Most of the approximately 7,000 people in Prince William Sound reside either in the two Alaska Native villages, Chenega Bay and Tatitlek, or the three larger communities Cordova, Valdez, and Whittier, two of which include Alaska Native vil

**Table 2.** Estimates of mean annual fishery landings and discards in Prince William Sound (1994-1996).

Group	Landings (t·km <sup>-2</sup> ·year <sup>-1</sup> )			Dead discards (t·km <sup>-2</sup> ·year <sup>-1</sup> )	
	Com- mercial <sup>a</sup>	Recrea- tional <sup>b</sup>	Subsis- tence	Com- mercial	Recrea- tional <sup>g</sup>
Adult salmon	5.3726	-	0.0002	-	-
Adult Pacific herring	2.5455	-	-	0.0551 <sup>e</sup>	-
Pollock 1+	0.1710	-	-	0.0103 <sup>f</sup>	-
Deep epibenthos	0.1430	-	-	-	-
Shallow demersals	0.0700	-	-	0.0001	-
Pacific cod	0.0656	-	-	0.0016	-
Pacific halibut	0.0268	0.0423	-	-	0.0015
Sablefish	0.0184	-	-	0.0008	-
Rockfish	0.0060	0.0039	-	0.0005	0.0020
Shallow large infauna	0.0030	-	-	-	-
Adult arrowtooth flounder	0.0004	-	-	0.0019	-
Deep demersal fishes	0.0003	-	-	0.0023	-
Sharks	0.0003	-	-	0.0022	0.0019
Lingcod	0.0003	0.0023	-	-	0.0002
Juv. arrowtooth flounder	0.0001	-	-	0.0019	-
Juv. Pacific herring	-	-	-	0.1189	-
Pinnipeds	-	-	0.0020	-	-
Totals	8.4234	0.0485	0.0022	0.1958	0.0037

a) adapted from commercial landings from B. Bechtol (ADF&G, unpublished data)

b) from Meyer (1999)

c) from Morestad *et al.* (1997)

d) from Frost (1999)

e) based on ballpark estimates by J. Wilcox, ADF&G (pers. comm., 25 Oct 1999)

f) based on postal surveys by Howe *et al.* 1995-1997

g) group-specific discard ratios calculated from data provided by M. Furuness, NMFS these ratios were applied to PWS landings data provided by B. Bechtol, AKF&G

h) from Hukbert (1999)

lage corporations. All of these communities rely on commercial fishing, though the native villages conduct subsistence fishing and gathering. In addition, Whittier is a growing hub of sportfishing activities, especially with the opening of a new road directly from Anchorage—Alaska's largest city. Much of the economy of Valdez relies on the southern terminus of the trans-Alaska pipeline where supertankers are loaded with oil for transport across the Gulf of Alaska and beyond (EVOS 2000). Considerable changes imposed on subsistence, commercial, and recreational fisheries, are related not only to the population fluctuations mentioned previously, but also due to a crash in the market value of wild salmon triggered by salmon farming (Folsom *et al.* 1992), and due to the catastrophic Exxon Valdez oil spill (see Picou *et al.* 1997).

The supertanker T/V *Exxon Valdez* ran aground on Bligh Reef in Prince William Sound causing the largest oil spill in United States history (over 40 million liters of crude oil). The oil spread throughout central and southwestern PWS, into the Gulf of Alaska, along the Kenai Peninsula, into Cook Inlet, to Kodiak Island, and along the Alaska Peninsula (see Figure 2 in Paine *et al.* 1996). The initial effects of the oil spill were catas-

trophic, killing several hundred thousand seabirds and other birds of 90 species; 3,500-5,500 sea otters; 1,000 bald eagles, 10% of the world's population of the threatened Kittlitz's murrelet; a number of killer whales; 300 harbor seals, other marine mammals; and vast numbers of fish, invertebrates, and plants (Loughlin 1994, Paine *et al.* 1996, Spies *et al.* 1996). Although the spill's full acute effects will remain uncertain, there is little doubt that they cascaded and reverberated through the impacted systems in addition to operating directly and immediately. Even more uncertain than initial impacts are questions of recovery, resiliency, and long-term effects (see Okey *et al.*, in prep.a).

A mass-balance model of the post-spill Prince William Sound food web (1994-1996) was constructed, refined, and disseminated during 1998 and 1999 (Okey and Pauly 1999a). The PWS model is available for downloading at no charge with the latest Ecopath with Ecosim software from [www.ecopath.org](http://www.ecopath.org), the derivations of its parameters are fully documented in Okey and Pauly (1999b), and the emergent characteristics of the model are described in greater detail in Okey *et al.* (in prep.a). In addition, a CD ROM containing the model and other Alaska resources is available (Okey *et al.* 2000).

The basic parameters for the Prince William Sound model are shown in Table 1. The basic input parameters production/biomass (P/B) and consumption/biomass (Q/B) are expressed in annual units. The ecotrophic efficiency (EE) is the proportion of production by a group consumed by predators or lost to export. This ratio, along with trophic level (TL) and omnivory index (OI), is calculated by the Ecopath formulation for each species. Detritus fate is a percentage allocation among detritus pools of the unconsumed and unexported production of a group. Values in bold were calculated by Ecopath; values not bolded are empirically-based input estimates contributed by a collaboration of experts on PWS, or estimates that were modified to achieve thermodynamic

**Table 3.** Economic values assigned to exploited PWS groups.

Group Name	Economic values of PWS animals (\$·kg <sup>-1</sup> )		
	Subsistence <sup>a</sup>	Recreational <sup>b</sup>	Commercial <sup>c</sup>
Halibut	-	60.10	6.01
Lingcod	-	39.10	3.91
Rockfish	-	39.10	3.91
Pinnipeds	8.50	-	-
Deep epibenthos	-	-	5.38
Sablefish	-	-	3.91
Adult arrowtooth	-	-	3.91
Pac. Cod	-	-	3.91
Juvenile arrowtooth	-	-	3.91
Deep demersals	-	-	3.91
Pollock 1+	-	-	3.91
Nearshore demersals	-	-	3.91
Adult salmon	3.75	-	3.75
Adult herring	-	-	2.49
Shallow large infauna	-	-	2.12

- The valuation of pinnipeds was based on figures provided by K. Frost, ADFG, pers. comm., 10 Aug 2000
- Recreational and sport fish values were considered to be an order of magnitude more valuable than commercial values (C. Walters, UBC Fisheries Centre, pers. comm., 20 July 2000)
- Calculated from landings and ex-vessel values provided by Frenette *et al.* (1997)

balance of the groups and the model (Okey and Pauly 1999a, b). The estimates of mean annual fishery landings and discards in Prince William Sound between 1994 and 1996 shown in Table 2 were used as inputs in the PWS model. Monetary values per unit of species captured by the fisheries were also input to the PWS model for the “economic” valuation in this analysis (Table 3).

Commercial ex-vessel values are from Frenette *et al.* (1997) and these were multiplied by 10 in order to derive values for recreationally captured fishes (as suggested by C. Walters, UBC Fisheries Centre, pers. comm., 20 July 2000). The estimated substance value of pinnipeds used here (\$8.50·kg<sup>-1</sup>) is the sum of the given edible value (\$5·kg<sup>-1</sup> of seal), the hide value (\$2·kg<sup>-1</sup> of seal), and the craft value (\$1.50·kg<sup>-1</sup> of seal) (K. Frost, ADFG, pers. comm., 10 Aug 2000). The commercial value of salmon was also used as the substance value of salmon.

A balanced trophic model of the Prince William Sound food web has been constructed using the Ecopath with Ecosim approach, but confusion exists among potential model users and decision-makers in Alaska about the nature of the approach and its degree of usefulness for practical fisheries management and planning. Dynamic simulation routines allowing exploration of the potential indirect effects of specified changes in fishing (or disturbance) are now supplemented with a suite of analytical tools for fishery policy

analysts. These new tools are designed to explore the potential effects and success of management policies on economic, social, and ecological resources (Walters, this volume). Application of this approach to the Prince William Sound model is presented here as a simplistic and preliminary exercise to evaluate the efficacy of this approach for the future planning of Alaska’s fisheries. The current analysis is simplistic because the contrasted policies are intended to represent the extremes of “economic,” “social,” and “ecological” objectives as defined by the author, for ease of comparison among different systems (this volume), and because the current version of the Prince William Sound model explicitly identifies only three broad fisheries categories: subsistence, recreational, and commercial, rather than individual gear types.

## Methods

A comparison of hypothetical policies that optimize ‘economic’, ‘social’, and ‘ecological’ considerations necessitates definitions of these terms that are unavoidably arbitrary to some extent.

The first problem is with the concept of ‘economy.’ If ‘economy’ is defined as a system or pattern of resource flow, and the goal of economic endeavors is the “thrifty use of resources” (Merriam-Webster 1995), then optimization of economic goals on the broadest time scale and trophic scales would lead to the application of negative discount rates (natural capital would be considered to increase in value over time). A broad definition of economy would also lead to a valuation of ecosystem services that converges with, rather than contrasts with, ecologically-based valuations. However, the economic/electoral system in the United States and throughout most of the world emphasizes decisions that maximize short-term individual self-interest, rather than broader scale and longer-term self interests. In order to contrast “economic” with the other two objectives, then, the operational concept of short-term economic interests is used here in place of the inherently broader concept of ‘economic interests.’

Social considerations encompass a wide spectrum of connections between human and natural communities of Prince William Sound. Because most these aspects are impossible to quantify for the purposes of comparative analysis, one single aspect of social considerations — employment value — is used here as a proxy for this complex realm. Employment value is defined here as number of jobs per captured unit of a particular biotic group that is targeted by a fishery.

The quantification of ecological considerations for comparison to short-term economic and employment considerations also presents a potentially challenging dilemma. One approach is to attempt monetary valuation of natural capital, based on ecosystem services and utilitarian assumptions (e.g., Costanza *et al.* 1997). However, a less value-laden approach is to use inherent biological properties to optimize particular qualities of interaction webs. Following this approach, the inverse of the ratio of production to biomass was used as a weighting factor to optimize food web structure and ecological quality, as it was considered to be a meaningful ecological property. This weighting factor ( $1/(P/B)$ ) gives higher weight (“importance”) to slower-growing and longer-lived species in the system’s interaction web, thus favoring ‘K-selected’ species. This would, in theory, maximize the number of trophic levels possible in the system and optimize the overall trophic transfer efficiency. Fishing strategies that lead to such ecological reconstruction would amount to ‘fishing the food web back up,’ rather than ‘fishing down the food web’ (Pauly *et al.* 1998). Given this structure-based definition, ecological considerations are here labeled ‘ecosystem structure.’

After developing the operational definitions of these three basic objectives, the policy search simulations were set up in Ecosim by conducting the following steps in addition to checking the appropriateness of default settings. The four species in the model containing explicitly separated ontogenetic stages were linked in the ‘stage’ interface, and the parameters specifying the character of their linkage were scrutinized. The prey vulnerabilities were specified to one of the three vulnerabilities used in this exercise (0.2, 0.4, and 0.7). These specify the relative importance of top-down vs. bottom-up forces influencing each interaction. They can be set for individual interactions, but one of the three settings was applied to the whole system for each of the three ‘sensitivity’ variants of each scenario.

Although the five apex predators in the system as well as birds, Pacific herring, salmon, and lingcod exhibited dramatic positive biomass responses to scenarios in which ecological considerations were optimized, Pinnipeds proved to be the most sensitive biological component of the Prince William Sound model with respect to declines and extinction responses. For this reason, the pinniped group, which consists mainly of harbor seals (*Phocenia phoca*) in Prince William Sound, was

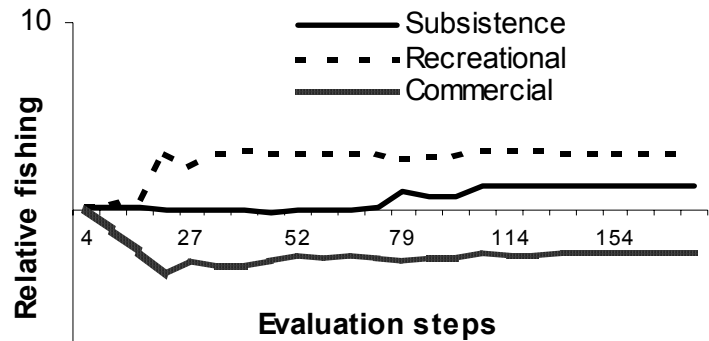

**Figure 1.** An example of a search for optimum beginning catch rates relative to 1994-1996 Prince William Sound catch rates, here for the weighted compromise scenario. This procedure finds the ideal starting catch rates for each fishing category based on the specified parameters. The ending values shown here are used as the starting values for the 20-year dynamic policy simulation

chosen as the ecological endpoint for development of the weighted compromise of the more simplistic simulations. Numerical stabilization of harbor seal biomass was used as the assessment endpoint, and various policies were explored around that goal. Fishing restrictions estimated from this goal would represent the minimal that would be necessary to protect pinnipeds in Prince William Sound for two reasons: (1) the simulations assume a pinniped population in equilibrium rather than accounting for the currently observed decline in the PWS harbor seal population, and (2) the numerical stabilization goal does not account for any rebuilding of the harbor seal population that might be deemed appropriate. However, indicated restrictions in fishing are simplistic because of the broad categories of fishing that are used, and population responses to limits in fishing could mean either direct or indirect effects of fishing levels imposed by Ecosim, thus revealing only the potential for such responses in the system.

The ‘non-linear search procedure for optimum fishing strategy over time’ was prepared for each scenario (e.g., Figure 1). Each search was started at the base fishing mortalities specified in the 1994-1996 PWS Ecopath model. The search was run using the Fletch method; and the annual economic discount rate was kept at 0.04 for all simulations. The objectives (“economic,” employment, and ecological) were defined by entering their quantitative definitions (see above) into the Ecosim interfaces provided for employment and ecological definitions (“economic” considerations are defined by local market values of captured species specified in the Ecopath model; Frenette *et al.* 1997). Each search was then run according to the

optimized objective. In these extreme simulations, the optimized objective was given a value of 1.0 while the remaining two were given values of 0.0001. All three objectives were set at 1.0 in the simple compromise scenario, and then multiple searches were conducted to find the values that achieved the assessment endpoint. The scenario that achieved the assessment endpoint was used as the weighted compromise.

These searches for optimal fishing patterns over time (according to specified objectives) resulted in initial fishing levels that were considerably different from those in Prince William Sound between 1994 and 1996. For example, the new 'starting' fishing rates for these hypothetical 20-year simulations contrasted profoundly with the actual (1994-1996) rates (Figure 2).

Starting with these new fishing strategies, which solved for the constraints imposed by the defined objectives, the simulations were run in 'closed loop' mode to simulate the dynamic interplay between fishery managers and all the biotic components of the food web. The results of these simulations were recorded by transferring run results onto spreadsheets. Predicted changes in relative biomass levels for the four main simulations (by the end of 20 year runs) were plotted, as were predicted changes in catches by the three fisheries categories, for each optimization scenario. These resulting values of each of the three objectives were then compared to values resulting from 'open loop' simulations in which no management error exists. This is further explained below.

Walters (this volume) asks us to imagine a fishery manager who has perfect knowledge of the system, and can instantaneously make perfect management decisions in the context of goals we have specified be optimized. For each scenario, this hypothetical manager-demon can optimize specified values of living resources while losing none of that value to uncertainty or managerial fallibility. The resulting values from these perfect 'open-loop' simulations are then compared with the values resulting from the dynamic 'closed loop' simulation in which information and manage-

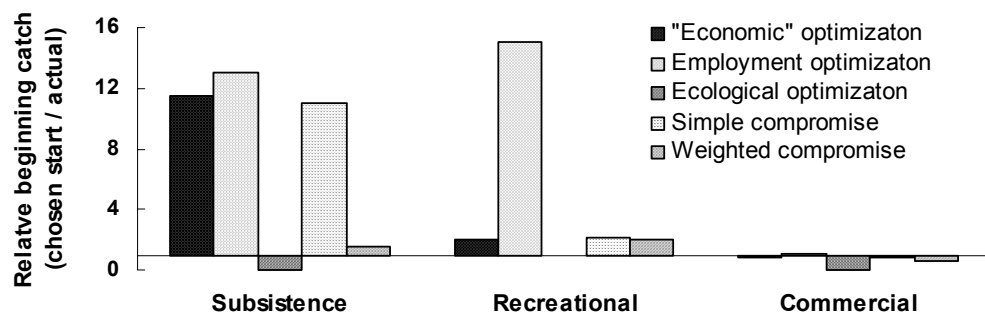

**Figure 2.** Ratios of the new 'starting' catch rates to the 1994-1996 actual catch rates for the three identified fishing categories in PWS. These new fishing rates were derived by the Ecosim optimization given specified economic, employment, and ecological objectives. Ecosim increased beginning subsistence catches considerably in three of the scenarios and it increased recreational catches considerably for one of the scenarios.

ment decisions are simulated to be imperfect. Although the formulation of this imperfectness is itself imperfect in Ecosim, it is imperfect in a consistent way such that this method can be used to compare fishing categories and optimization scenarios.

Finally, the mean of the relative temporal variability (over the 20-year simulations) of all biotic components was calculated for each scenario to investigate the sensitivity of the represented biota (and the overall food web) to various prey vulnerability settings, which control the ratio of top-down vs. bottom-up dynamics in the system. In addition, the variance of the 'system spread' of the relative ending values among species was calculated. The results of these sensitivity tests were plotted against vulnerability setting and fishing category.

## Results

Optimization of either short-term economic value or employment value, to the exclusion of other considerations, lead to policies that caused organisms to decline or to be fished to extinction, while salmon and two gadoid species (i.e. Pacific generally similar trends: some upper trophic level cod and sablefish) of 'upper-mid' trophic levels increased. Optimizing strictly social (employment) considerations lead to management strategies that drove halibut, lingcod, and pinnipeds to extinction, while optimizing strictly economic considerations lead to strategies that drove only pinnipeds to extinction during the 20 year simulations (Figure 3).

Conversely, the scenario designed to optimize only ecological considerations lead to increases in biomass of high trophic-level predators, such as orcas, sharks, halibut, porpoise, pinnipeds, and lingcod, as well as seabirds, avian predators (eagles and falcons), Pacific herring, and salmon. It



**Figure 3.** Predicted changes in biomass of medium and high trophic level species by the end of a 20 year simulation designed to optimize short-term economic goals and a 20 year simulation designed to optimize employment goals. The 28 most responsive species out of a total of 49 groups are presented in decreasing trophic order from left to right. Most of the unresponsive groups were in lower trophic levels (not included in this figure).

also lead to decreases in the gadoids Pacific cod, sablefish, and Pollock, as well as decreases in the forage fishes eulachon, capelin, sandlance, and nearshore demersal fishes and rockfish (Figure 4).

Placing equal weight on all three objectives (short-term economic, employment, and ecological considerations) lead to a result that was essentially the same as the optimization of short-term economic objectives (Figure 4). The selected assessment endpoint for this system (numerical stability of pinnipeds) was achieved only by weighting the ecological objectives by at least a factor of 3.2 over both economic and employment objectives; by a factor of 1.7 over short-term economic objectives (giving no weight to employ-

ment objectives); or by a factor of 1.6 over employment objectives (giving no weight to short-term economic objectives). Catches were predicted to decrease considerably from the 1994-1996 catch levels for every optimization scenario and for every fisheries category, with the exception of the recreational catch in the employment simulation, which remained at 1994-1996 levels (Figure 5).

The relative success of managing the optimization of “economic,” employment, and social values varied according to objective. When managing for the goal of ecosystem structure, the hypothetical human fisheries manager enjoyed near perfect success relative to the perfect Walters’ demon, but the ecological optimization was the only sce-

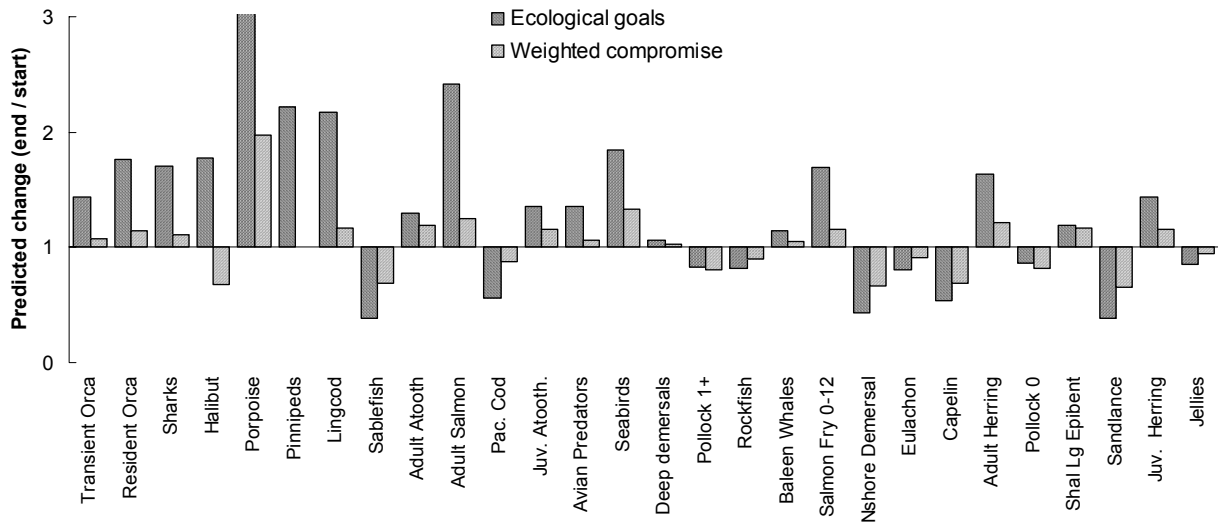

**Figure 4.** Predicted changes in biomass of medium and high trophic level species by the end of a 20 year simulation designed to optimize ecological goals presented with a 20 year ‘weighted-compromise’ simulation designed to meet the assessment endpoint of pinniped population stability. The predicted porpoise increase after 20 years exceeds the scale at 3.84 times the 1994-1996 level. The 28 most responsive species, out of a total of 49 groups, are presented here in descending trophic order from left to right. Most of the unresponsive groups were in lower trophic levels (not included in this figure).



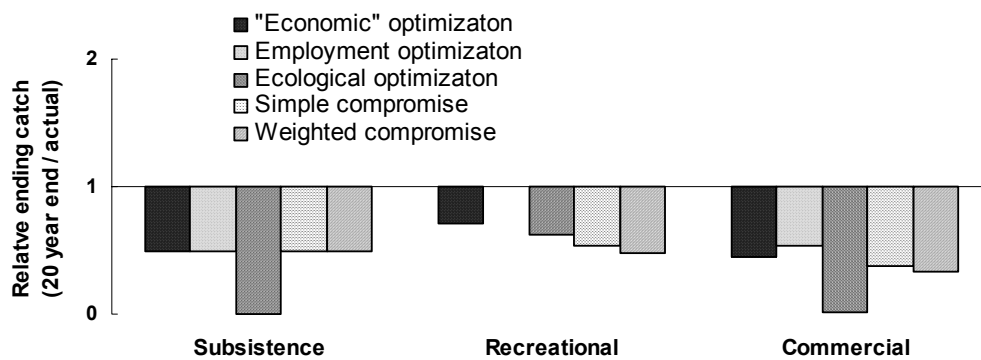

**Figure 5.** Differences in catches between the actual 1994-1996 levels and the catch levels predicted end of the 20 year simulation. A more explicit specification of gear types in the model might have lead to predicted catch increases in some groups, but the same general trend would be expected. Considerable decreases in catches might have resulted from aggressive initial catch levels in order to maximize values early based on the algorithm of the policy search procedure in Ecosim, but it also may indicate that 1994-1996 catch levels were higher than sustainable in an ecosystem context.

nario with essentially perfect overall managerial success (Table 4). In contrast, the simulated human manager was far from perfectly successful at meeting the ‘economic’ and employment value goals set by Walter’s demon. The overall success of the weighted compromise was also relatively high because ecosystem structure was heavily weighted in that scenario (Table 4).

Both sensitivity measures — the means of the 20-year temporal variances of the biomasses of all biotic groups, and the whole-system ‘spread’ of the ending biomasses relative to the beginning biomasses — increased considerably when the prey vulnerability settings were set at 0.7 than when they were set at 0.2 or 0.4. The increases in the variance values between the 0.4 and 0.7 were relatively dramatic in almost all of the simulations, indicating a non-linear relationship of sensitivity of the model to vulnerability settings (Figures 6 and

gear types. This broad approach to fisheries parameterization enables an equally broad view of the interaction of fishing sectors, biota, and policy, and the results are intriguing and informa-

7).  
**Discussion**

Although the Prince William Sound model is among the most explicit Ecopath models with respect to articulation of biotic groups (Okey and Pauly 1999 a, b), the fisheries information is currently aggregated into subsistence, recreational, and commercial categories rather than into more specific

**Table 4.** Comparison of economic, employment, and ecosystem values resulting from management of Prince William Sound fisheries by the hypothetical Walters’ demon (a manager who has perfect information and makes perfect decisions). These are compared with values resulting from management decisions of a simulated fallible human manager. Values displayed represent resulting values after 20 years of management with each approach. The success of achieving ecosystem structure goals is essentially 1.0 in every optimization, indicating that no knowledge is needed to optimize ecosystem structure, and most the actions necessary are removals of human interaction (i.e. fishing).

Optimization goals	Walters' demon (perfect decisions)	Chasing Walters' demon ('human' decisions)	Success index
<i>Economic' optimization</i>			
Net short-term econ value	1262.28	908.29	0.72
Employment (social) value	1576.26	1077.98	0.68
Ecosystem structure	3164.3	3151.47	1.00
Overall value	1.1	0.79	0.72
<i>Employment optimization</i>			
Net short-term econ value	748.59	724.8	0.97
Employment (social) value	1767.83	1181.43	0.67
Ecosystem structure	2829.95	2841.82	1.00
Overall value	1.23	0.82	0.67
<i>Ecological optimization</i>			
Net short-term econ value	257.17	192.79	0.75
Employment (social) value	290.78	211.72	0.73
Ecosystem structure	4368.31	4364.67	1.00
Overall value	1.32	1.32	1.00
<i>Simple compromise</i>			
Net short-term econ value	1261.65	885.51	0.70
Employment (social) value	1590.69	1057.93	0.67
Ecosystem structure	3145.53	3133.33	1.00
Overall value	3.16	2.45	0.78
<i>Weighted compromise</i>			
Net short-term econ value	1117.62	796.96	0.71
Employment (social) value	1364.57	928.08	0.68
Ecosystem structure	3512.67	3490.11	0.99
Overall value	5.32	4.71	0.89

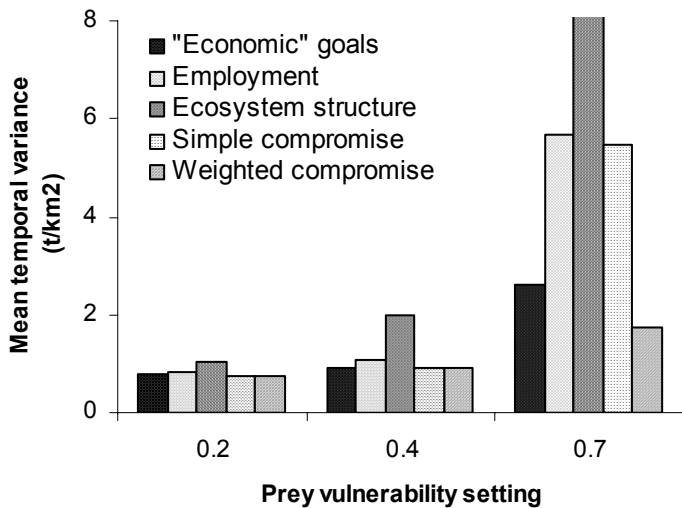

**Figure 6.** The means of the 20 year temporal variances of the biomass of all biotic groups according to optimization scenario and vulnerability setting. This sensitivity test shows a considerable increase in mean temporal variances between the prey vulnerability settings of 0.4 and 0.7, indicating that the dynamic behavior of the model is stable at overall prey vulnerabilities of 0.4, but not as stable at 0.7. The value of the bar that exceeds the scale is 39. The results presented in this paper were from simulations run with vulnerability settings of 0.4

tive on this broad level. However, recognizing the generalized scale of this fisheries parameterization is crucial for unambiguous interpretations. More explicit articulation of fisheries information (i.e., by specific gear type) would lead to policy solutions in which Ecosim could control individual gear types independently. This would undoubtedly lead to different specific outcomes for individual biotic groups and individual fisheries, though the general patterns would likely be unchanged from the current more general approach.

The present Ecosim policy analysis of the Prince William Sound Ecopath model indicates some exceptions to the conclusion of Trites *et al.* (1997) that competition between fisheries and marine mammals generally do not stress marine mammal populations. The positive responses in Figure 4 indicate notable population effects of competition between several high trophic level species and local fisheries; and these fisheries are thought to be of relatively moderate intensities. However, the distinction between indirect (competitive) forcing and direct fishery effects is a crucial first step to interpreting the results of these simulations. In general, transient orcas, resident orcas, porpoise, sharks, seabirds, and avian predators (eagles and falcons) responded as negatively-affected competitors of fisheries for food (see in-

creases when fisheries are decreased; Figure 4) while halibut, pinnipeds, lingcod, salmon, and herring responded as negatively-affected, direct targets of fisheries (see responses in Figures 3 and 4). The gadid-like fishes sablefish and Pacific cod acted like positively-affected targets of fisheries—species that are generally facilitated by fisheries. The negative responses of nearshore demersals to decreased fishing (Figure 4) is probably the result of increased competition with salmon fry and herring as the latter populations recover.

These simulations pre-suppose an isolated system, though constant immigration and emigration rates can be specified. Isolation is a useful assumption for examining potential trophic forces within the system, but the results of such simulations should always be interpreted in the context of larger regional changes, which affect the system. This is particularly important when examining results of characteristically transboundary species, such as forage fishes and transient predators. As a simple hypothetical example, the real trend in forage fishes such as capelin and sandlance might be to increase because of factors external to the PWS system, discussed later in relation to observed pinniped declines.

The pinniped group (mostly harbor seals) was chosen as the ecological endpoint for this study because that group was most sensitive to the pre-defined policy scenarios. Two other high preda-

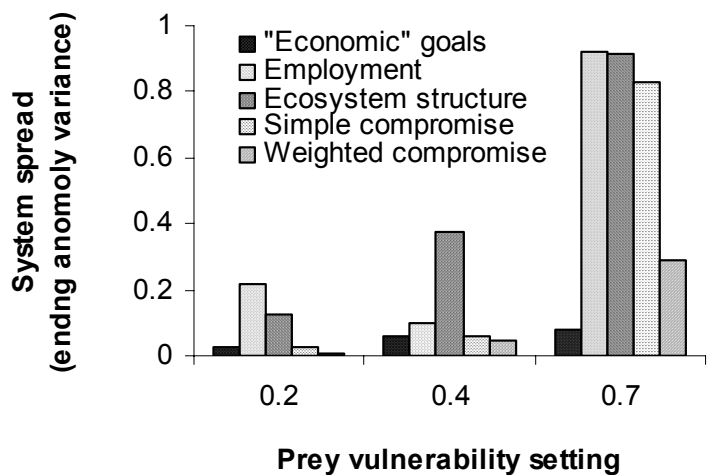

**Figure 7.** Results of an additional sensitivity test, similarly showing a considerable increase in the relative “system spread” at the end of the 20 year simulations. This ‘whole system’ variance describes the overall change of the food web as forced by simulated trophic interactions.

tors in the system, halibut and lingcod, were fished to extinction alongside pinnipeds in the simulation designed to optimize employment goals. The explanation for these three extinctions is that Ecosim optimized the system's employment goals by eliminating the competitors of the fisheries for the prey—sablefish, salmon, and Pacific cod—which hold higher employment value in the system (This implies that pinnipeds, halibut, and lingcod consume fish desired by the fisheries; it does not imply that these three predators cannot presently find enough to eat, or even that the three prey species in question are the primary prey of pinnipeds). Subsistence catches were increased by a factor of 12 to eliminate pinnipeds quickly. That would not be allowed in the current pinniped co-management regime. The sustainability of the current subsistence take of pinnipeds was not evaluated here.

The abundances of sablefish, salmon, and Pacific cod increased when their natural predators were reduced or eliminated because their natural mortalities decreased, enabling fishing mortalities (and employment) to increase. The three higher predators were essentially sacrificed by an employment-minded Walters' demon because their prey hold much higher employment value, being lower in the food web and containing much higher biomasses. This strategy for employment (and economic) optimization conducted by Ecosim is illegal, and would not be undertaken by fisheries managers in the region; but it is important that this incentive-driven strategy for 'fishing down the food web' is here revealed by Ecosim, as this mechanism likely operates in the real world, albeit sometimes by default (by accident) rather than on purpose.

In the real world, as fisheries shift toward lower trophic level targets, direct pressures on the highest-level predators might ease short of biological extinctions, but these populations would become more vulnerable to food and disease stress after their targeted prey decrease in abundance. The reduction of these high level predators in the system can thereby be driven from above (direct fisheries effects) and from below (indirect fisheries effects and oceanographic-driven changes in system production). The true reason for pinniped declines in Prince William Sound and the surrounding region is still ambiguous, but there is good evidence that food stress is not a factor in those declines (K. Frost, ADFG, pers. comm., 10 August 2000; and discussed later).

The optimization of 'economic' goals was achieved by the same strategy of increasing abundances of some upper-mid trophic level fishes

through the reduction or elimination of top predators, but in this case the goal was to achieve the highest monetary flow from the overall system rather than employment opportunity. The patterns and the mechanisms were similar to those in the employment simulation (Figure 3). In both cases, resident orcas increase slightly rather than decrease because their salmon and herring prey increase and fisheries cannot kill them (in the model); transient orcas, however, decrease because their mammal prey decreases in these two scenarios.

Examination of Figure 4 is still more informative about the state of the Prince William Sound food web. The analysis predicts that managing for the optimization of purely ecological goals, as presently defined, leads to a system in which the high level predators become considerably more abundant after 20 years while some mid-level fishes decrease (though both ontogenetic stages of salmon and herring increase). Furthermore, the only two groups to decrease out of the 15 highest trophic levels in the system are sablefish and Pacific cod. The 16<sup>th</sup> group, walleye pollock older than one year, is decreased from their original biomass like the two other gadoids in the system—sablefish and Pacific cod.

The increases, or 'recovery', of these species indicates either a release from competition for food or a release from direct take, which differs among species. For example, harbor seals are likely to be responding to decreases in direct mortality. But this rebounding assumes that no external factors might prevent recovery of these species, such as lingering pollution associated with the Exxon Valdez oil spill, increasing fluxes of predators from other systems, or a major shift in the diets of predators. Prey switching is incorporated in Ecosim, but even small deviations of predicted prey switching from real world scenarios can make a significant difference for sea otter, porpoise, or harbor seal populations because, for example, Orcas are capable of consuming considerable quantities (Estes *et al.* 1998). The achievement of these ecological policy goals was predicted to contain no human error. That is to say, the simulated 'human' manager enjoyed virtually 100% success relative to the ecological Walters' demon, which had perfect information and made perfect decisions (Table 4).

These results provide three main insights: (1) optimization of ecological goals carries no associated management error because the only actions required to achieve those ecological goals are reductions in human interactions with the ecosystem (assuming the system does not stabilize at a

degraded alternate state); (2) if a reduction of exotic disturbances such as modern industrial fishing and oil spills would really favor 'K-selected' species, as disturbance theory suggests, the rebounding of upper trophic levels shown in Figure 4 indicates that the Prince William Sound food web is considerably degraded, but has the potential to recover (this interpretation would be in error for species exposed to sources of mortality that are not included in the model. Pinnipeds might be one example of this); (3) both ontogenetic stages of salmon and herring are necessary for recovery of high trophic level species, and system integrity. These four groups increased in the 'ecological optimization' despite being weighted relatively low when specifying the ecological considerations (they have relatively high P/Bs).

A fourth interpretation that is more speculative and contentious is that gadoid fishes, such as sablefish, Pacific cod, and walleye pollock are 'weedy' species whose elevated abundances in this system indicate modification of the system by fishing. This interpretation would lump gadoid fishes with species that become abundant in stressed systems, such as capitellid polychaetes in polluted sediment (Pearson and Rosenberg 1978), polychaetes in frequently trawled areas of the sea floor (Engle and Kvittek 1998), or Eurasian weed plants in disturbed soil throughout the "neo-european" colonies (Crosby 1986). Evidence contrary to this notion includes arctic areas that have high abundances of gadoids in the absence of human fishing, and areas like the George's Banks in the western north Atlantic where the abundance of cod was unbelievable to newly arrived Europeans (K. Frost, ADFG, pers. comm., 10 August 2000; and discussed later).

It was not surprising that the weighted compromise scenario in which ecological goals were weighted 3.2 times both the "economic" and employment goals revealed a pattern similar to the ecological optimization pattern, though less extreme. Although this weighted compromise might not be ubiquitously viewed as an effective compromise, it achieves the goal of numerical stabilization of pinnipeds, identified previously as the assessment endpoint. However, such allocational discomfort can be replaced by systemic discomfort upon scrutiny of Figure 5, which shows that Ecosim not only decreased allocation to all fishing categories in almost all scenarios by the end of the 20-year simulations, but it shows that the fishing solution associated with the weighted compromise is within the range of the fishing decreases in the "economic" and employment optimizations. The consistent reduction of catch in all cases is another indicator that catch rates are

generally too high to optimize anything in the Prince William Sound system.

Good evidence suggests that the declining population of pinnipeds in Prince William Sound is not limited by food (K. Frost, ADFG, pers. comm., 10 August 2000). The current simulation indicates that direct take in the subsistence fishery is a potentially critical source of pinniped mortality in the system, but the adjustments to the subsistence fishery that were necessary to achieve the weighted compromise were over-simplified because different subsistence fishing practices were aggregated into a single fishing category. Specification of fishing types at a finer resolution would allow the adjustment of direct pinniped take to be separate from other subsistence categories when exploring extreme policy scenarios. The reasons for the observed long-term decline in harbor seals in Prince William Sound and the surrounding region are uncertain, but the direct take of pinnipeds in Prince William Sound may be a much less important factor than predation by transient orcas or sharks (K. Frost, ADFG, pers. comm., 10 August 2000), which may have shifted feeding patterns in response to declines in other food throughout their broader ranges (e.g., Estes *et al.* 1998).

Questions of the relative importance of the various factors that may drive currently observed pinniped declines could be addressed by combining Ecopath approaches with other approaches in the future, but these questions are beyond the scope of the present analysis. The important point here is that Ecopath's solution to sacrifice pinnipeds and other high trophic-level predators in order to optimize the extreme "economic" and employment objectives was illegal, but revealing of incentives that might drive real dynamics in this or other systems. The problem of renegade solutions confronted in this analysis helped initiate the development of a 'mandated re-building' input interface in the upcoming version of Ecosim's policy analysis package (V. Christensen, UBC Fisheries Centre, pers. comm., 29 August 2000).

The reliability and usefulness of the solutions and predictions presented in this paper depend on the quality of the parameters used to represent the 49 categories in the model of the PWS food web. The derivations of these parameters are fully documented in Okey and Pauly (1999b). They also depend on the aggregation of the model and of the fisheries information (discussed above and in Okey and Pauly 1999 a, b). Finally, they depend upon the behavior and dynamic stability of the model. A variety of approaches can be taken to

evaluate this behavior and dynamic stability. The approach taken here is based on the assumption that food webs are inherently stable in the real world within the context of endemic regimes of production and natural disturbances, and likewise the mixture of top-down and bottom-up forces that are particular to that setting. The range of prey vulnerability settings explored during the sensitivity test represents these different regimes of top-down and bottom-up forces. The sensitivity of the results of the model is illustrated by the weighted compromise; the weighting value of 3.25 lead to stability of pinnipeds when a vulnerability setting (V) of 0.4 was used, but  $V = 0.2$  lead to a gradual rise of pinnipeds over the 20 year simulation while  $V = 0.7$  lead to their extinction at approximately the 20 year horizon.

The observed non-linear increase of the system variance values as vulnerability settings were increased from 0.2 to 0.7 implies onset of instability at high vulnerability settings, as expected. The goal of the sensitivity test was to choose a vulnerability setting that does not exceed the level associated with (unrealistic) instability, though some instability should be expected, especially in a system modified by exotic disturbances, and especially for species at high trophic levels. Organisms at high trophic levels would have the most plastic (adaptive) behaviors giving individuals the ability to adapt behaviorally to changing ecological and food-web conditions. The discovery of instability at this level of the food web at high vulnerabilities is simply an indicator that the intelligence and sociality of these high trophic animals are incompletely captured by the model, and this is not surprising. An alternate explanation is that real instabilities occur in the upper trophic levels of systems that are exposed to persistent or strong stress, particularly where exotic stresses have been prevalent, as in Prince William Sound. In this sense, 'instable' behaviors of high trophic levels would be consistent with real world dynamics.

Notwithstanding these considerations, no severe instabilities were revealed in the PWS model, just a non-linear trend in values for mean temporal variances and the variance among the 20 year ending values of the whole system (Figures 6 and 7). In spite of the relative stability of the PWS model, a reasonably low vulnerability setting 0.4 was chosen for the simulations. This value was chosen in the interest of interpretive conservatism, as low vulnerability values emphasize the prevalence of bottom-up forces in the system rather than top-down forces. Still, the results of the Prince William Sound model, or any Ecopath model, tend to over state the operational importance of competitive interactions in the system

because non-biotic, physical forcing is traditionally underemphasized in Ecopath models. The point of this type of dynamic modeling, however, is to reveal the potential biotic forces in the system, which can then be interpreted in the context of non-biotic forces.

The results of these preliminary and exploratory analyses of extreme fishery management policy alternatives in Prince William Sound, with the development of a weighted compromise, indicate that the PWS food web may be currently fished at or beyond the limits of sustainability, in the context of the whole food web. They indicate this for any objective defined here including "economic," employment, or ecological goals and the simple and weighted compromise developed within the constraints of aggregated fisheries information. One caveat to this gloomy implication is that the model of Prince William Sound represents a post-oil spill scenario (the state of the system 5-7 years after the spill). It follows that a system degraded by a catastrophic oil spill might not be able to sustain the intensity of fishing that would be expected or hoped for. Similar analyses on a pre-spill Prince William Sound system, if a comparable model existed, might reveal far more sustainable values of these living resources, whether the values in question are economic, social, or ecological. It is somewhat surprising and notable, however, that the sacrifices from the fisheries sectors required to provide pinnipeds with the minimum safeguard from extinction in the system (numerical stability at the present level through the weighted compromise) are not appreciably more severe than would be required to meet the other objectives explored in this analysis (Figure 5). It is vitally important to emphasize again that more explicit articulation of fishery sectors in this analysis would have produced more informative results with respect to specific fishing activities.

### Acknowledgements

The Prince William Sound food web model was constructed by a broad collaboration of experts representing large teams of scientists and students. The main active contributors of this knowledge are listed in the aforementioned citations documenting the model's construction. K. Frost's comments were particularly helpful with the interpretations of the analyses, though agreement was incomplete. We thank the Exxon Valdez Oil Spill Trustee Council for supporting the construction of this model. We thank Professor D. Pauly for his excellent leadership and D. Priekshot and J. Dalsgaard for laying crucial groundwork for the model construction. We also thank Professor S. Pimm and B. Powell from the University of Tennessee for helpful criticism of the PWS model. Finally, Professor C. Walters developed Ecosim, and V. Christensen developed its easy-to-

understand software package.

## References

- Brodeur, R. D., B. W. Frost, S. R. Hare, R. C. Francis, and W. J. Ingraham, Jr. 1996. Interannual variations in zooplankton biomass in the Gulf of Alaska and covariation with California current zooplankton biomass. *California Cooperative Oceanic Fisheries Investigations Reports* (37): 80-100.
- Cooley, R. A. 1961. Decline of Alaska's salmon: a case study in resource conservation policy. Ph.D. dissertation, University of Michigan, Ann Arbor.
- Cooney, R.T. 1993. A theoretical evaluation of the carrying capacity of Prince William Sound, Alaska, for juvenile Pacific salmon. *Fisheries Research* 18: 77-87.
- Crosby, A. W. 1986. *Ecological Imperialism*. Cambridge University Press, Cambridge.
- Costanza, R., R. d'Arge, R. de Groot, S. Farber, M. Grasso, B. Hannan, K. Limberg, S. Naeem, R. V. O'Neill, J. Paruelo, R. G. Raskin, P. Sutton, and M. van den Belt 1997. The value of the world's ecosystem services and natural capital. *Nature* 387: 253-260.
- Dayton, P. K. 1975. Experimental studies of algal canopy interactions in a sea otter-dominated kelp community at Amchitka Island, Alaska. *Fishery Bulletin* 73: 230-237.
- Dumond, D. E., and R. L. Bland. 1995. Holocene pre-history of the northernmost north Pacific. *Journal of World Prehistory* 9(4): 401-451.
- Engle, J. and R. Kvitek. 1998. Effects of otter trawling on a benthic community in Monterey Bay National Marine Sanctuary. *Conservation Biology* 12(6): 1204-1214
- Estes, J. A. *et al.* 1998. Killer whale predation on sea otters linking oceanic and nearshore ecosystems. *Science* 282: 473-476.
- Estes, J. A., and D.O. Duggins. 1995. Sea otters and kelp forests in Alaska: generality and variation in a community ecological paradigm. *Ecological Monographs* 65(1):75-100.
- Estes, J. A. and J. F. Palmisano. 1974. Sea otters: their role in structuring nearshore communities. *Science* 185:1058-60.
- Estes, J. A., N. S. Smith, and J. F. Palmisano. 1974. Sea otter predation and community organization in the western Aleutian Islands. *Ecology* 59: 822-833.
- EVOS Trustee Council. 2000. GEM Science Program NRC Review Draft. Prepared by the Exxon Valdez Oil Spill Trustee Council, April 21, 2000.
- Francis, R. C., S. R. Hare, A. B. Hollowed, and W. S. Wooster. 1998. Effects of interdecadal climate variability on oceanic ecosystems of the northeast Pacific. *Fisheries Oceanography* 7(1): 1-21.
- Frenette, B., M. Mcnair, and H. Savikko. 1997. Catch and production in Alaska's commercial fisheries, 1995 Edition. Alaska Department of Fish and Game, Commercial Fisheries Management and Development Division, Special Publication 11.
- Frost, K. J., L. F. Lowry, and J. M. Ver Hoef. 1998. Monitoring, habitat use and trophic interactions of harbor seals in Prince William Sound. Restoration Project 97064, Annual Report. Anchorage, Alaska: Exxon Valdez Oil Spill Restoration Office.
- Frost, K. J. 1999. Pinnipeds. In T.A. Okey and D. Pauly (eds). Trophic mass-balance model of Alaska's Prince William Sound ecosystem, for the post-spill period 1994-1996, 2<sup>nd</sup> Edition. University of British Columbia, Vancouver, Fisheries Centre Research Reports 7(4), 136 pp.
- Folsom, W., D. Altman, A. Manuar, F. Neilson, T. Tevord, E. Sandborn, and M. Wildman. 1992. World salmon culture. National Oceanic and Atmospheric Administration Technical Memorandum NMFS-F/SPO-3, 323 pp.
- Heard, W. R., A. M. Anderson. 1999. Alaska Salmon. in *Our Living Oceans*. Report on the status of U.S. living marine resources, 1999. U.S. Dep. Commer., NOAA Tech. Memo. NMFS-F/SPO-41.
- Holling, C. S. 1973. Resilience and stability in ecological systems. *Ann. Rev. Ecol. Syst.* 4: 1-23.
- Hollowed, A. B. and W. S. Wooster. 1992. Variability of winter ocean conditions and strong year classes of Northeast Pacific groundfish. Pp. 433-444. ICES Marine Science Symposium.
- Howe, A. L., G. Fidler, C. Olnes, A. E. Bingham, and M. J. Mills. 1997. Harvest, catch, and participation in Alaska sport fisheries during 1996. Alaska Department of Fish and Game, Fishery Data Series No. 97-29, Anchorage.
- Hulbert, L. 1999. Sharks. in T.A. Okey and D. Pauly (eds.). Trophic mass-balance model of Alaska's Prince William Sound ecosystem, for the post-spill period 1994-1996, 2<sup>nd</sup> Edition. University of British Columbia, Vancouver, Fisheries Centre Research Reports 7(4), 136 p.
- Jacobson, L. D., F. C. Funk, and B. J. Goiney. Pacific coast and Alaska pelagic fisheries. in *Our Living Oceans*. Report on the status of U.S. living marine resources, 1999. U.S. Dep. Commer., NOAA Tech. Memo. NMFS-F/SPO-41.
- Kvitek, R. G., J. S. Oliver, A. R. de Gange, and B. S. Anderson. 1992. Changes in Alaskan soft-bottom prey communities along a gradient in sea otter predation. *Ecology* 73(2): 413-428.
- Loughlin, T. R. (ed.). 1994. *Marine Mammals and the Exxon Valdez*. Academic Press, Inc. San Diego. 395 p.
- Low, L., J. N. Ianelli, S. A. Lowe. 1999. Alaska groundfish fisheries. in *Our Living Oceans*. Report on the status of U.S. living marine resources, 1999. U.S. Dep. Commer., NOAA Tech. Memo. NMFS-F/SPO-41.
- Mantua, N. J., S. R. Hare, Y. Zhang, J. M. Wallace, and R. C. Francis. 1997. A Pacific interdecadal climate oscillation with impacts on salmon production. *Bulletin of the American Meteorological Society* 78(6): 1069-1079.
- Merriam-Webster. 1995. Merriam Webster's Pocket dictionary. Merriam-Webster Inc., Springfield, Massachusetts, 405 pp.
- Meyer, S. 1999. Recreational landings in PWS. in T.A. Okey and D. Pauly (eds.). Trophic mass-balance model of Alaska's Prince William Sound ecosystem, for the post-spill period 1994-1996, 2<sup>nd</sup> Edition. University of British Columbia, Vancouver, Fisheries Centre Research Reports 7(4), 136 pp.
- Morstad, S., D. Sharp, J. Wilcock and J. Johnson. 1997. Prince William Sound Management Area 1996. Annual Finfish Management Report. Alaska De-

- partment of Fish and Game. Commercial Fisheries Management and Development Division, Central Region, Anchorage, Alaska.
- NOAA. 1984. <http://www.co-ops.nos.noaa.gov/benchmarks/9454050.html>
- NRC. 1996. The Bering Sea Ecosystem, National Research Council, National Academy Press, Washington, DC
- Okey, T. A., C. Young, A. Poon, D. Pauly 2000. Alaska's Aquatic Ecosystems CD-ROM, Fisheries Centre, University of British Columbia, Vancouver BC, [www.fisheries.ubc.ca](http://www.fisheries.ubc.ca)
- Okey, T.A. and D. Pauly. 1999a. A mass-balanced model of trophic flows in Prince William Sound: De-compartmentalizing ecosystem knowledge, p. 621-635. In Ecosystem approaches for fisheries management. University of Alaska Sea Grant, AK-SG-99-01.
- Okey, T.A. and D. Pauly (editors). 1999b. Trophic mass-balance model of Alaska's Prince William Sound ecosystem, for the post-spill period 1994-1996, 2<sup>nd</sup> Edition. University of British Columbia, Vancouver, Fisheries Centre Research Reports 7(4), 136 pp.
- Okey, T. A. (other authors to be determined) D. Pauly. (in prep.a) Can oil spills shift marine ecosystems to alternate stable states?: simulations with an Ecopath model of Prince William Sound, Alaska. (Target journal: Ecological Applications).
- Paine, R.T., J.L. Ruesink, A. Sun, E.L. Soulanille, M.J. Wonham, C.D.H. Harley, D.R. Brumbaugh, and D.L. Secord. 1996. Trouble on oiled waters: lessons from the *Exxon Valdez* oil spill. *Ann. Rev. Ecol. Syst.* 27: 197-235.
- Pauly, D., V. Christensen, J. Dalsgaard, R. Froese, F. Torres, Jr. 1998. Fishing down marine food webs. *Science* 279(5352): 860-863.
- Pearson, T. H., and R. Rosenberg. 1978. Macrobenthic succession in relation to organic enrichment and pollution of the marine environment. *Oceanographic and Marine Biology Annual Review* 16: 229-311.
- Piatt, J. F. and P. Anderson. 1996. Response of common murrelets to the Exxon Valdez oil spill and long-term changes on the Gulf of Alaska marine ecosystem. Pages 720-737 in S. D. Rice, R. B. Spies, D. A. Wolf, and B. A. Wright (eds) Proceedings of the Exxon Valdez Oil Spill Symposium. American Fisheries Society.
- Picou, J. S., D. A. Gill, and M. J. Cohen, eds. 1997. The Exxon Valdez disaster: readings on a modern social problem. Kendall/Hunt Publishing Company, Dubuque, Iowa.
- Pitcher, T. 1998. Pleistocene pastures: Steller's sea cow and sea otters in the Strait of Georgia in D. Pauly, T. Pitcher, and D. Preikshot (eds.) Back to the Future: Reconstructing the Strait of Georgia Ecosystem. Fisheries Centre Research Reports 6(5): 48-52.
- Reeves, J. E., and B. J. Turnock. 1999. Alaska shellfish fisheries. in Our Living Oceans. Report on the status of U.S. living marine resources, 1999. U.S. Dep. Commer., NOAA Tech. Memo. NMFS-F/SPO-41.
- Rosenkrantz, G. 1999. Statistical modeling of tanner crab recruitment. Thesis. University of Alaska Fairbanks, Alaska.
- Simenstad, C. A., J. A. Estes, and K. W. Kenyon. 1978. Aleuts, sea otters and alternative stable state communities. *Science* 200: 403-411.
- Sousa, W. P. 1984. The role of disturbance in natural communities. *Annual Review of Ecology and Systematics* 15: 353-391.
- Spies, R. B., S. D. Rice, D. A. Wolfe, B. A. Wright. 1996. The effects of the Exxon Valdez oil spill on the Alaskan coastal environment. p. 1-16. In: Rice, S. D., R. B. Spies, D. A. Wolfe, and B. A. Wright (eds.). Proceedings of the Exxon Valdez Oil Spill Symposium. American Fisheries Society Symposium 18, Bethesda.
- Springer, A. M. and S. G. Speckman. 1997. A forage fish is what? Summary of the Symposium. Forage Fishes in Marine Ecosystems, Alaska Seagrant College Program, AK-SG-97-01.
- Trites, A. W., V. Christensen, and D. Pauly. 1997. Competition between fisheries and marine mammals for prey and primary production in the Pacific Ocean. *J. Northw. Atl. Fish. Sci.* 22: 173-187.
- Tyler, A. V. and G. H. Kruse. 1996. Conceptual modeling of brood strength of red king crabs in the Bristol Bay region of the Bering Sea high latitude crabs: biology, management, and economics. Alaska Sea Grant College Program, AK-SG-96-02. 512-543.
- Wertheimer, A. C. 1997. The status of Alaska salmon. In D. J. Strouder, P. A. Bisson, and R. J. Naiman (eds.) Pacific salmon and their ecosystems: status and future options. Symposium Proceedings, Seattle, Washington, January 10-12, 1994, P. 179-197. Chapman Hall, New York.
- Wheelwright, J. 1994. Degrees of Disaster: Prince William Sound: How Nature Reels and Rebounds. Simon and Schuster, New York, 348 pp.
-

## Exploring Alternative Management Policies: A Preliminary Ecological Approach for the San Matias Gulf Fishery, Argentina

Villarino María Fernanda,  
Mario L. Lasta and Marcelo Pájaro  
INIDP, Mar del Plata, Argentina

### Abstract

The San Matías Gulf is located along the Argentinean coast in the Southwest Atlantic (41° 47' -S-62° 50' W). First target species were bivalves (*Aequipecten tehuelchus*) and hake (*Merluccius hubssi*). Commercial vessels are equipped by: bottom net (T), longliner (LL) and the artisanal fleet longline (LL). The values of fixed cost are 40 %, effort cost 33 % and sailing cost 3 %. The model was built with 19 compartments with a detritus group included. Results indicate that in all tested policies the relationship E/S of catch, value and cost are increased. When ecosystem stability is maximized, those increases are small and when the net economic value is maximized, the increases are the highest. When the social value aspect is maximized the increases fall between the values from net economic and ecosystem maximization. It is observed that the increase suggested by the model for the LL, agree with the actual increase of the LL fleet in the fishery and the partial reduction of the T fleet. The mean trophic level of the catch is on the order of 4.05. The gross efficiency is 0.000126. The values from the Ecoranger routine suggest that some P/Q and EE are high.

### Introduction

The San Matías Gulf is located along the Argentinean coast in the Southwest Atlantic Ocean, approximately between 41° 47' to 42° 13' S and 62° 50' to 63° 48' W. The gulf is a big basin, deeper in the center (up to 200 m), and connected to the shelf on the east through a wide mouth (101 km) with a shallow sill (50 m). The total surface is approximately 13,600 km<sup>2</sup> and 55% of the area is deeper than 100 m. Tides are in the order of 6-7 m and responsible for strong currents. San Matías Gulf is a semi-closed area with its own oceanographic characteristics.

In the vicinity of 41° 50' S, a relatively intense thermohaline front is found. Cold-fresh waters dominate the south of the front while warm-salty waters, typical of the gulf, are found north of the front (Piola & Scasso, 1988). The circulation is dominated by a cyclonic gyre of approximately 70 km in diameter located north of the front. Direct observations of currents indicates mean velocities of 0.14 m/s. Oceanographic studies indicate that a

cold water mass originating in the southwest penetrates into the gulf, flows northward, and finally drives seaward for the north-east section of the mouth.

Water temperature in the winter (average 11.26°C; sd: 0.08) reveals a well mixed water column indicative of a deep-reaching convection and bottom ventilation. In the summer, temperature reaches 18°C and salinity is higher than 34 SPU (Scasso & Piola, 1988).

During March, chlorophyll *a* is of the order of 0.5 to 0.7 mg/m<sup>3</sup> suggesting low productivity (Carreto *et al.*, 1974). In May values of chlorophyll *a* are observed of the order of 0.26 to 1.97 mg/m<sup>3</sup> being the maximum related to the northwest shore (Carreto *et al.*, 1974). During November, high salinity, temperature and nutrients concentration are the conditional factors for low chlorophyll *a* values in shallow waters (northwest). In the southeastern area of the gulf, the water is observed to have low salinity and temperature, with higher values of chlorophyll *a*, 0.3 to 0.7 mg/m<sup>3</sup> (Carreto *et al.*, 1974).

Commercial fishing activities began in the 70's. The initial fleet was composed of small fishing vessels approximately 12 m long. First target species were bivalves (mussels, *Mytilus edulis platensis* and scallops *Aequipecten tehuelchus*), hake (*Merluccius hubssi*), mackerel (*Scomber japonicus*), sharks (*Callorhynchus callorhynchus*), flatfish (*Paralichthys sp.*, *Xystreuris sp.*) and other demersal fish (*Seriolaella porosa*, *Macruronus magellanicus*, *Acanthistius brasiliensis*, *Genypterus blacodes*) (Lasta, 1988).

At present, the fleet includes 61 ships (Di Giacomo & Perier, 1992; Gonzalez, 2000), composed of three different types of vessels. The bigger ones (a) are approximately 30 m long and equipped with bottom nets. The medium-sized vessels (b) are on average 25 m long and equipped with longline and finally, the artisanal fleet (c), is composed of small boats that range between 8 to 15 m long and are equipped with long-line. Regarding the activity (annual trips, 1999) of each fleet, there is an observed inverse relationship between the activity and the average length of the vessel: 542 trips for "a" fleet; 1,149 for "b" and 4,115 trips for "c" fleet (Redes, 2000). The jobs/catch for each fleet are 0.01, 0.08 and 0.04 for a, b and c fleet respectively. The most important market of the catch is export, not for domestic consumption.

According to the economic information, the values of fixed cost are about 40 %, effort related



**Table 1.** San Matias Gulf fishery. Alternative policies results maximizing: net economic value, social (employment) value and/or ecosystem stability aspects. Fleet: Trawl (T), Small Longliner (SLL) and Big Longliner (BLL).

Policy	Name	Economic Social Ecosystem	Values (E/S) of: Catch, Value and Cost	Comments
P 1	Basic	1	All values increase (on average) 5, 4 and 3 times. T and SLL increase all values between 6 and 4 times. BLL decrease all values 0.2 to 0.7 times.	Favours T and SLL fleet. BLL diminish.
	Economic +	0		
	Ecology	1		
P 2	Economic	1	All values increase (on average) 7, 8 and 5 times. SLL and BLL increase values in 13, 15 and 9 times. T increases values in 5 and 4 times.	Favours LL fleet.
		0		
		0		
P 3	Ecosystem	0	All values increase (on average) 15, 17 and 7 %. LL fleet has been favoured and SLL present higher values (42, 42 and 16 %) than BLL (17, 17, 8 %).	Favours SLL.
		0		
		1		
P 4	Social	0	All values increase (on average) 4, 6 and 3 times. SLL and BLL present similar values: 16, 17 and 9 times the initial one. T fleet was strongly diminished.	Strongly favours both SLL and BLL fleets.
		1		
		0		
P 3 <sup>a</sup>	Social + Ecosystem	0	All values increase (on average) 4, 6 and 3 times. SLL and BLL present similar values: 16, 18 and 9 times. T shows a strong decrease in values.	Strongly favours both SLL and BLL fleets.
		1		
		1		
P 5	Economic + Social + Ecosystem	1	All values increase (on average) 4, 6 and 3 times. SLL and BLL with values 16, 17 and 9 times. T fleet was strongly diminished.	Strongly favours both SLL and BLLs; T fleet low values.
		1		
		1		

cost 33 % and sailing related cost 3 %. The profit is different between bottom trawl (T) and longliner (LL) fleets approximately 16 and 28 % respectively.

During the initial years (70's) of the fishery the total catch did not surpass 4,000 t with the *Aequipecten tehuelchus* scallop and the mussel *Mytilus edulis platensis* as the target species. Total catch-landing during 1999 was about 12,000 t: fleet "a" brought in 9,370 t (48% hake), "b" 1,340 t (86% hake) and "c" 1,309 t (82% hake). Hake was the most important species with a total catch of 6,700 t for the whole fishery, considering all vessels and the target species of fleet "b" and "c".

A preliminary Ecopath model was constructed for the San Matías Gulf as an ecosystem. Most of the species present in the Gulf occur in the adjacent waters of the platform, however, stock identification studies suggest an independence in the Gulf hake population (Christiansen, 1980; Calvo, 1985; Bezzi, 1996) and other species (Giussi, 1999), from the populations that inhabit the shelf. This provides a justification for assuming that the San Matías Gulf behaves as a largely enclosed ecosys-

tem, with a minimal exchange of biomass with the shelf.

The goal of this work is to analyze, by simulating using Ecosim on a 20 years period, the reaction of the ecosystem to different management regimes (alternative policies). The different results (final/initial biomasses for each simulation) are compared with the present biomass.

## Data

The model was constructed starting in 1994, when the LL fleet was experimental. Data on catch, biomasses, fleet fishing effort and jobs/catch for this year was used as the starting point of each simulation.

The model was built with 19 compartments. Each represents organisms with a similar role in the food web. Those functional groups, in increasing order

of the trophic level were: phytoplankton (1), copepods (2), bivalves (2), shrimps (2), large zooplankton (2.5) small pelagic (3.1), jelly zooplankton (3.2), tail hake (3.6), squids (3.6), pelagic fishes (3.7), juvenile hake (3.8), benthic fishes (4), demersal fishes (4.2), sea birds (4.2), adult hake (4.3), sharks (4.6), rays (4.7), mammals (4.9), killer whales (5.9). A detritus group was also included.

Information on biomass was obtained from research surveys carried out in 1994 (INIDEP, H 0/07/94). P/B and Q/B were obtained from different sources as surveys, landings, literature (Fishbase, 1998) and personal communications.

## Results and Discussion

Results of alternative policies are presented in Table 1. The results are, in terms of quality of the ecosystem response in relation with: net economic value, social (employment) value and ecosystem stability objectives of maximization. Each policy was simulated for the fleet: Trawl (T), Small Longliner (SLL) and Big Longliner (BLL). Strong criteria were established to maximize the

alternative policies by using values of 1 or 0.001 to consider or exclude the three aspects of the policies.

The results indicate that in all the tested policies the relationship between end and start values (E/S) of catch, value and cost are increased. When ecosystem stability is maximized, those increases are small. In contrast, when the net economic value is maximized, the increases are the highest. When the social (employment) value aspect is maximized the increases fall between the values from net economic and ecosystem maximization. The social value seems to have a strong influence as suggested by the results observed when the social is combined with other objectives as in policies P3a (social+ecosystem) and P5 (economy+social+ecosystem).

As a general pattern it is observed that only in the case of the policy P1 (basic) the T fleet was favored jointly with the SLL. In all the other policies the T fleet was highly diminished and SLL and BLL showed increases.

The initial scenario (fleet, catch, etc.) and biological data was established in 1994. Comparing the present (1999) composition of the fleet and related catch with the predicted ones by the model, it is observed that the increase suggested by the model for the LL, agree with the actual increase of the LL fleet in the fishery and the partial reduction of the T fleet.

The results indicate that in all policies, with the exception of the P3 (ecosystem) there is a strong increase in the suggested values, mostly for the LL fleet. This would be due to an overestimation of the biomass and a higher production due to the relative decrease of the T fleet that affects juveniles.

No stock was depleted in all the scenarios simulated. The mean trophic level of the catch is on the order of 4.05. The gross efficiency is 0.000126.

Our ecotrophic mass-balance model for the San Matias Gulf is balanced. However, values from the Ecoranger routine suggest that some P/Q and EE are high. It is necessary to improve some of the input data to run Ecosim again and to check the output and to analyze management policies.

## References

Bezzi, S. 1996. Sobre la unidad poblacional de la merluza (*Merluccius hubbsi*) del Golfo San Matías. Inf. Téc. Int. INIDEP N°110/96, 2 pp.

- Calvo, J. 1985. Caracterización de los períodos de crecimiento de la merluza (*Merluccius hubbsi*) en el Golfo de San Matías, y variación de parámetros tisulares. Tesis Doctoral, Fac. Cien. Nat. y Museo, Univ. Nac. de La Plata.
- Carreto J. I., Verona, C. A., Casal, A. B. & Laborde, M. A. 1974. Fitoplancton, pigmentos y condiciones ecológicas del Golfo San Matías. III. CEGSM. (Noviembre de 1971). CIC, Informes 10, 49-76.
- Christiansen, H. E. 1980. Aplicación de la histometría en el estudio de las variaciones en las microcelulas de la musculatura blanca de la merluza (*Merluccidae, Merluccius hubbsi*), en la plataforma argentina; su importancia. Tesis Doctoral, Fac. Cien. Nat. y Museo, Univ. Nac. de La Plata.
- Di Giacomo, E. E. & Perier, M. R. 1992. Retracción de las pesquería demersal del Golfo San Matías: ¿Escasez de recursos o disminución de la eficiencia? Frente Marítimo, 11(A): 7-13.
- Giussi, A. R.; Hernandez, D. & Abachian, V. E. 1999. Differences in growth of long tailed hake (*Macruronus magellanicus*) from two areas of South Western Atlantic Ocean. Seminario Final Proyecto INIDEP – JICA, 135-138.
- Gonzalez, R. 2000. Notas y comentarios sobre el proceso de transformación del sector pesquero rionegrino en el período 1990-1998. IBMyP Alnte. Storni, Doc. Téc. 04/00.
- Lasta, M. L., Iribarne, O. O., Pascual, M. S., Zampatti, E. A. & Vacas, H. C. 1988. La pesquería del Golfo San Matías: una aproximación al manejo experimental. Inf. Unesco Cienc. Mar. 47: 168-175.
- Piola A. R. & Scasso L. M. 1988. Circulación en el Golfo San Matías. Geoacta 15 (1): 33-51.
- Redes de la Industria Pesquera Argentina 2000. Año 13, n° 112.
- Scasso L. M. & Piola, A. R. 1988. Intercambio neto de agua entre el mar y la atmósfera en el Golfo San Matías. Geoacta 15(1): 13-31.

## Exploring multispecies harvesting strategies on the eastern Scotian Shelf with Ecosim

Alida Bundy<sup>1</sup>

<sup>1</sup>BIO, DFO Dartmouth, NS

### Abstract

Multispecies management strategies for capture fisheries on the eastern Scotian Shelf were investigated using a recently developed formal optimisation routine in the tropho-dynamic simulation model, Ecosim. Harvesting strategies were optimised using economic, social and ecosystem goal functions. Two contrasting results were obtained, depending on model start conditions (i) where vulnerabilities were set at 0.4 for all groups, except cod/sand lance interactions which were set at 0.9 and (ii) where vulnerabilities varied with trophic level. In (i) the economic and social goal functions did not have much effect on economic or social scores, whereas the ecosystem goal function improved the ecosystem score. However, all optimisations led to a decrease in the overall score. In (ii) the ecosystem goal function had little effect on the ecosystem score, while the economic and social goal functions lead to improved economic and social scores. The economic and social goal functions increased the overall score whereas the ecosystem goal function decreased it. Economic, social and ecosystem goal functions have different management implications. A trade-off analysis indicated that as the ecosystem goal function is given more weight, the economic and social scores decrease. The ecosystem score did not improve above a weighting of 10, but the social score decreased considerably. These results indicate that developing multispecies harvesting strategies is a complex task, goal functions may be conflicting and initial model conditions can affect results.

### Introduction

Multispecies management strategies for capture fisheries were investigated using a recently developed formal optimisation routine in the tropho-dynamic simulation model, Ecosim. The “Fishing Policy Search” routine allows the user to optimise economic, social or ecosystem goal functions. This routine was used with an Ecopath model of the eastern Scotian Shelf, Canada.

Until the 1990s, the eastern Scotian shelf supported a substantial groundfish fishery (cod, haddock, American plaice), the bulk of which was caught by large groundfish trawlers. Other important fisheries included silver hake and redfish, as well as a spectrum of other species. By 1993, the groundfish resource base, and in particular

cod, had collapsed and a moratorium was placed on the fishery. In 2000, the cod have not recovered and the fishery has not re-opened. Fisheries for invertebrates such as shrimp, crabs and bivalve molluscs have developed as fishers have switched targets to other species. The value of the total catch has been maintained (Liew 1997).

The Ecopath model describes the eastern Scotian shelf system for the time period 1980-1985, prior to the collapse of cod when the biomass of many species was relatively stable. There are 35 functional groups, including 3 fish groups that are split into juvenile and adults, in order to account for trophic ontogeny. The structure of the model is similar to the Ecopath model of the Newfoundland-Labrador shelf (see Bundy *et al.* 2000 and Vasconcellos *et al.*, this report, for a flow diagram). Nine fisheries were identified in the model, see Table 1. This model will be fully described in a forthcoming DFO technical report. This paper uses preliminary model results.

The model was manually fitted to a time series of relative abundance data (cod, haddock, American plaice, flounders, skates, pollock and sand lance) in a rough replication of the collapse of the groundfish stocks. The fishing mortality rates of the large and small mobile fleets were increased four fold from 1985 to 1993, when fishing by these two fleets ceased as a result of the moratorium. All other fleets fished at the constant 1980-1985 rate until 1993. The optimisation runs begin in 1993, after the collapse of the cod and groundfish fisheries.

The aim of this work was to explore multispecies harvesting strategies using the policy optimisation routine. The objective functions of the policy optimisation routine are defined as follows:

- Economic: estimated as total landed value of the catch minus total operating costs required to land this value
- Social: employment is used as the social indicator, and is assumed proportional to the landed value of the catch

**Table 1.** Socio-economic input parameters.

Name of fleet	Fixed cost (%)	Effort related cost (%)	Sailing related cost (%)	Profit (%)	Total value (%)	Jobs/Catch
Large mobile gear	30	20	20	30	100	1
Small mobile gear	30	20	15	35	100	4
Silver hake fishery	30	20	20	30	100	2
Redfish fishery	30	20	15	35	100	2
Large Long line	30	20	15	35	100	1
Small Long line	30	20	10	40	100	3
Nets	30	20	10	40	100	3
Shrimp fishery	30	20	10	40	100	5
Crab Fishery	30	20	10	40	100	5

- Ecosystem: measured by the departure of biomass from a specified target biomass ( $B_{ideal}/B_{base}$ ).

Values for the attributes of the objective functions were varied and sensitivity to key Ecosim parameters such as vulnerabilities tested. In all runs, the economic data, and the attributes of the social objective function were set as outlined in Table 1. These are not empirical values derived from fisheries data. They are based on typical values suggested by Dr. Rashid U. Sumaila (Fisheries Centre).

The following analyses were conducted:

1. *Baseline runs to optimise for economic, social and ecosystem goal functions.* In each run, the goal function to be optimised was set to 1, and the other 2 were set to 0.001. The ecosystem was defined as:  $B_{ideal}/B_{base}$  – Cetaceans =10, Grey seals = 1, Seabirds = 3, other fish groups = 2; Importance – importance of all species =1, except mature and immature cod = 2. Vulnerabilities were set at 0.4 for all groups, except cod/sand lance interactions which were set at 0.9, defining strong top-down interactions.
2. *The importance criterion of the ecosystem goal function defined as 1/PB.* The aim was to investigate a possible criterion for defining importance in the ecosystem attribute. Other settings are as in (1).
3. *Assume that vulnerabilities are proportional to trophic level.* Ecosim simulations can be very sensitive to the value set for the vulnerability parameter in the consumption estimates. A possible approach is to assume that vulnerabilities are proportional to trophic level (ie., the top of the food web would be subject to top-down control and the bottom of the food web would be subject to bottom-up control). Other settings are as in (1).
4. *Test sensitivity to feeding parameter.* The feeding time adjustment rate was set to 0.5 by default in the above simulations. This assumes that in times of scarcity, all groups will increase the time spent foraging, and thus their vulnerability to predation. This was revised

**Table 2** - Results of the base optimisations using the economic, social and ecosystem goal functions.

	No optimisation	Goal Function		
		Economic	Social	Ecosystem
Economic	29.35	31.01	28.28	9.55
Social	125.37	79.34	125.74	26.39
Ecosystem	-8010.53	-8192.08	-8109.01	-6121.08
Overall	3	1.03	2.04	-2.22
Fished $B_{end}/$ Fished $B_{start}$	1.01	0.80	0.89	1.07
Total $B_{end}/$ Total $B_{start}$	1.03	1.06	1.07	1.02
<b>Groups lost</b>	None	Silver hake, Skates, Dem.pisc.	Silver hake, Skates	Sand lance

groups with the exception of the 3 immature groups which were set to 0.5, to reflect that juveniles are more likely, due to high  $Q/B_s$ , to increase their time feeding when prey is scarce. Other settings are as in (1).

5. Look at trade-off between economic, social and ecosystem goals. The above simulations were run for a single goal function. Here, the trade-off between goal functions was examined. The economic and social goal functions were set to 1, whilst the ecosystem goal function was varied from 0.1 to 1000.

Each run was started with Ecopath base fishing mortality rates, then 1-3 runs using the current fishing mortality rates to ensure that the optimisation routine has found the real optima, and not a local maxima. Several optimisations with random fishing mortality rates were also run to test for consistency.

## Results

### 1. Base optimisations

The results in Table 2 demonstrate that the optimisation routine does optimise for the specified goal function. Compared to the results when there is no optimisation, the ecosystem goal function performs well for the ecosystem score. However, the economic and social indicators were not much

**Table 3.** Comparison of fishing rates per fleet for Analyses 1 to 4. (1) Baseline run; (2) The group importance is defined as equal to 1/PB; (3) Assumes vulnerabilities are proportional to trophic level; (4) Feeding rate sensitivity.

Analysis	Economic			Social			Ecosystem			
	(1) Base	(3) V = TL	(4) Feeding rate	(1) Base	(3) V = TL	(4) Feeding rate	(1) Base	(2) Imp. = 1/PB	(3) V = TL	(4) Feeding rate
Fishing Gear										
Large mobile gear	0.1	1.2	0.1	0	0	0	0	0.1	0.1	0.1
Small mobile gear	0.2	2	0.2	4.4	20.9	5.1	0.1	0.2	0.9	0.3
Silver hake fishery	17.7	20.1	16.5	24.1	20.1	20.1	1	3	2.6	0.3
Redfish fishery	3.5	2.2	4.3	4.7	3	5.1	0.2	0.2	0.3	0.2
Large Long line	10.1	1.5	7.9	1	0.1	0	0.2	0.3	1.4	0.2
Small Long line	0.6	1	0.8	20.1	20.7	20	0.8	0.9	0.8	0.6
Nets	0.2	0.6	0.7	0.7	0.8	1.1	0.5	0.7	0.8	0.9
Shrimp fishery	0.9	1	1.2	1.4	1.4	1.2	0.9	1	0.9	0.9
Crab Fishery	2.8	1.1	1.3	2.6	20.2	3	1.1	1.1	1.1	1

**Table 4.** Optimisation results when ecosystem importance attribute is defined as 1/PB.

	Ecosystem Goal
Economic	10.95
Social	30.19
Ecosystem	-70,334
Overall	-4.97
Fished B <sub>end</sub> /Fished B <sub>start</sub>	1.07
Total B <sub>end</sub> /Total B <sub>start</sub>	1.04
Groups lost	none

improved by the economic and social goal functions. The economic and social goal functions perform badly with respect to the ecosystem score, while the ecosystem goal function performs very badly with respect to the economic and social scores.

In the economic optimisation, the landed value is increased, due to increased catch of crabs, haddock, cod, redfish and American plaice. The silver hake fishery is increased 18 fold, effectively fishing out the silver hake and presumably releasing the above species from predator control (Table 3). The fishing rates of the redfish, long line and crab fisheries are increased to take advantage of this increased bounty. Large and small mobile gears are reduced to 10% and 20% of their initial values, and nets (gillnets and purse seines) are reduced to 20 % of their initial value. The total fished biomass is 80% of the initial fished biomass and the total biomass of the system is a little higher than the initial total biomass. Three groups disappear by the end of the simulation.

The social optimisation also results in a very high fishing rate for the silver hake fishery, effectively fishing this predator species to zero biomass. The landed value is increased, due to increased catch of crabs, haddock, cod, and American plaice. The fishing rates of the fisheries which employ higher numbers of fishers for landed value are all increased, that is small mobile gear, small long line gear, crab and shrimp fisheries. The total fished biomass is 89% of the initial fished biomass and the total biomass of the system is a little higher than the initial total biomass. Two groups disappear by the end of the simulation.

In the ecosystem optimisation, the fishing rates of all fleets are reduced, except the silver hake fishery, which remains the same and the crab fishery, which is increased slightly (Table 3). The silver hake fishery is maintained to reduce predation and/or competition with cod, which is given more importance than the other groups in the ecosystem attributes. Total landed value and to-

tal catch are reduced. The total fished biomass is greater than the initial fished biomass. The total biomass of the system is a little higher than the initial total biomass, but not as high as the total biomass generated by the economic and social optimisations. This could be because the economic and social optimisations fish out the predators to let lower trophic levels increase to provide abundant resources for the fishery. However, one group, sand lance, was lost to the system under the ecosystem goal function.

*2. The importance criterion of the ecosystem goal function defined as 1/PB.*

In this optimisation, species with low production rates are given more importance than species with high production rates. Thus marine mammals are given more importance than fish and fish are given more importance than highly productive invertebrate species. The management policies implied by the fishing rates resulting from the ecosystem optimisation are not qualitatively different from the results given above, with the exception that the silver hake fishery is increased almost 3 fold (Table 3). However, no groups were lost during this optimisation.

However, the optimisation performs very badly for the ecosystem score (Table 4). This performance is poor since the ecosystem goal function is more challenging than the one defined above where only cod, which had collapsed, were given an importance value of 2. Here, cetaceans, grey seals, seabirds, redfish, dogfish and crabs all have importance greater than 6. If the biomass of the functional groups in analyses (1) and (2) are compared (Figure 1), most are greater when PBs are used to define the importance attributes of the ecosystem goal function, whilst the silver hake biomass, as a result of increased fishing rate, is greatly reduced. This optimisation also performs marginally better on the economic and social scores, compared to analyses (1).

*3. Assume that vulnerabilities are proportional to trophic level.*

The system is more resilient under the assump-

**Table 5.** Optimisation results when vulnerabilities are directly related to trophic level.

	No optimisation	Economic	Social	Ecosystem
Economic	13.39	34.51	30.9	18.77
Social	32.53	103.22	141.33	49.04
Ecosystem	-6225.86	-7548.63	-7590.69	-6100.63
Overall	-1.17	1.15	2.29	-2.18
Fished B <sub>end</sub> /Fished B <sub>start</sub>	0.97	1.60	1.67	0.99
Total B <sub>end</sub> /Total B <sub>start</sub>	1.01	1.22	1.28	1.02
Groups lost		Silver hake Skates	Cod, Silv. hake Skates	

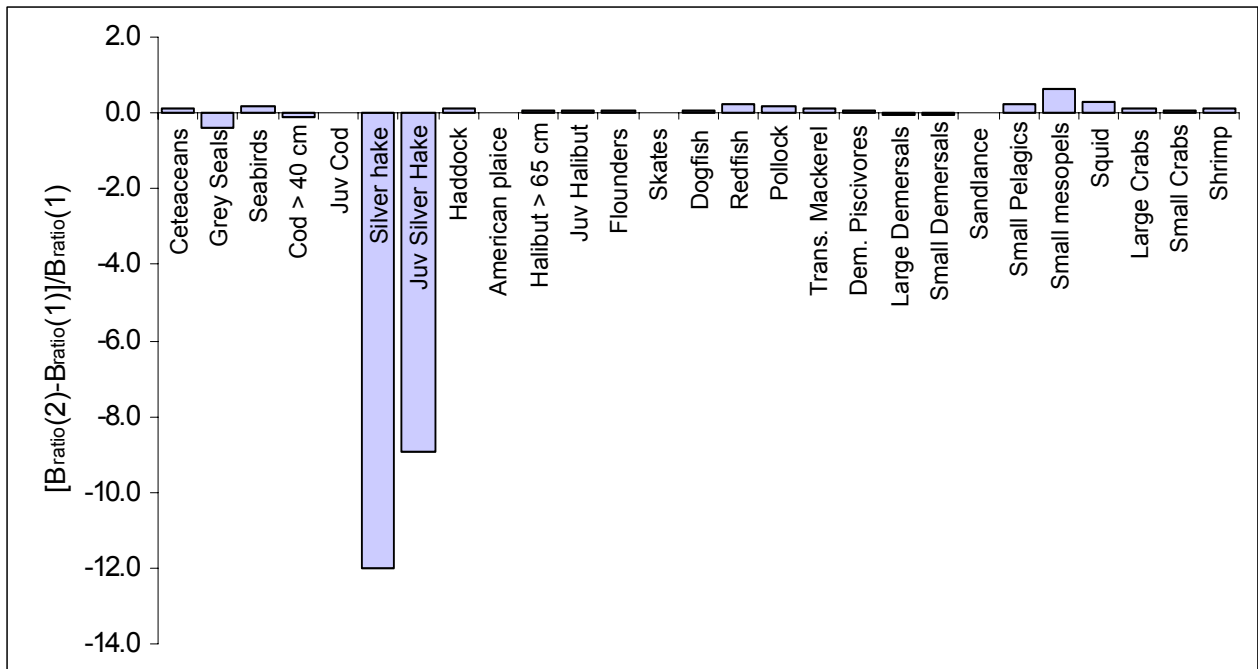

**Figure 1.** Comparison of end biomass/start biomass from results of analyses (1) and (2) above for the ecosystem goal function.

tion that vulnerabilities are related to trophic level, and supports a higher fishing rate. Under all runs, the end total biomass is greater than the start total biomass (Table 5), and the scores in Table 5 are better than the scores for the base simulations (1) in Table 2.

The economic, social and ecosystem scores are all improved by the economic, social and ecosystem goal functions respectively. Compared to the results when there is no optimisation, the economic and social goal functions perform well for the economic and social scores (Table 5). However, the ecosystem goal function does not perform much better than when there is no optimisation. This is in contrast to the results in Table 2.

Both the economic and social optimisations increase the catch, landed value and biomass of fished groups. Both also increase the fishing rate of the silver hake fishery to the point where silver hake is lost from the system, as in Analysis (1). Again, the predator is removed and the abundance of its prey and competing groups increases. In the economic optimisation, the fishing rates of all fleets are slightly increased, except for the small long line, nets and shrimp, which are reduced, while the landed value and catch increase. In the social optimisation, the large mobile gear is reduced to zero effort, while the small mobile gear, silver hake fishery and small

long line gear are increased 20 fold, effectively removing cod, silver hake and skates from the system. The ecosystem optimisation reduces the catch and landed value considerably, but succeeds in maintaining all functional groups in the system, and in particular cod. The fishing rate of silver hake fishery is increased, again to reduce predation by silver hake. The fishing rate of other gears remains near 1, except large mobile gear and redfish gear, which are reduced to 0.1 and 0.3 respectively. Table 3 compares these fishing rate changes with the results from Analysis (1).

4. Test sensitivity to feeding parameter.

The fishing rate scenarios resulting from these optimisations are not qualitatively different from the results for Analysis (1), with the exception of the ecosystem optimisation, which has a much lower fishing rate for silver hake (Table 3). The economic and ecosystem goal functions result in marginally higher scores than in Analysis (1) and the social goal function has a marginally lower score (Table 6).

**Table 6.** Optimisation results when feeding time parameter = 0, and juvenile groups = 0.5.

	No optimisation	Economic	Social	Ecosystem
Economic	14.95	32.69	26.8	11.61
Social	35	83.44	124.73	32.32
Ecosystem	-5794.36	-6594.33	-7049.49	-5755.6
Overall	-0.92	1.09	2.02	-2.05
Fished B <sub>end</sub> /Fished B <sub>start</sub>	1.06	0.81	0.8	1.12
Total B <sub>end</sub> /Total B <sub>start</sub>	1.01	1.04	1.05	1.02
Groups lost	none	Silver hake Halibut	Silver hake	none

5. Trade-off between economic, social and ecosystem goals.

The trade-off used Analysis 3, where vulnerabilities were assumed to be relative to trophic level. Figure 2 shows the optimisation scores for a range of weightings, from 0.1 to 100, for the ecosystem goal function. The economic, social and ecosystem goal functions have an inflexion point when the

ecosystem goal function is a given a weighting of 10. The social goal function has a second inflexion point when the ecosystem function has a weighting of 50. The scores continue to improve after the inflexion points, but marginally. The response of the fishing rate predictions to the changing weight of the ecosystem function are more complex (Figure 3). The fishing rate of the redfish fishery and small mobile gear decrease immediately, whilst the silver hake fishery, small long line and crab fishery have inflexion points at ecosystem weightings of 5, 10 and 50 respectively. The fishing rates of the shrimp fisheries, large long line and nets increase, and have inflexion points at ecosystem weightings of 1, 5, 5 respectively.

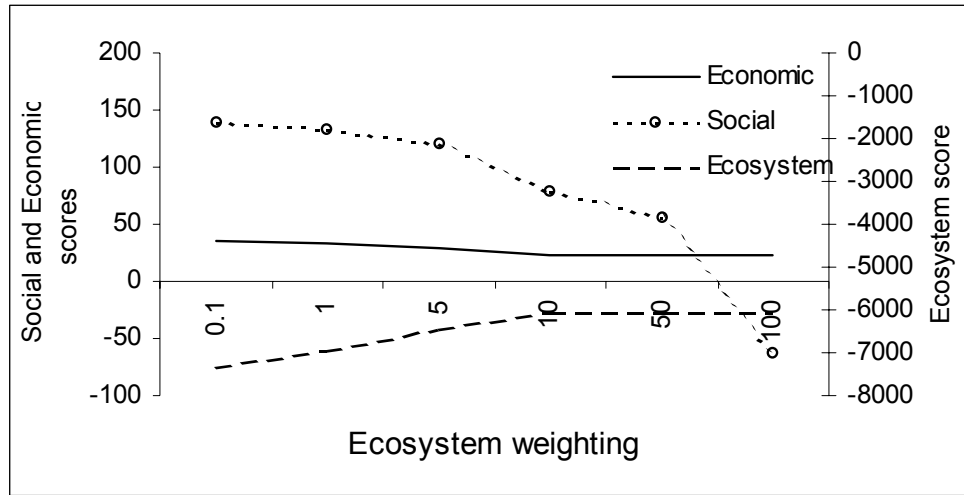

Figure 2 Comparison of scores for a range of ecosystem weightings.

There is no distinct flip point from one type of policy to another. An ecosystem weighting of about 5 to 50 appears to be the transition stage: the social and economic goal functions dominate the results up to an ecosystem weighting of 5, the ecosystem goal function dominates when the ecosystem weighting is greater than 10.

6. Random fishing rates

All the above optimisations were also run starting from random fishing rates. For the economic and ecosystem goal functions, it was always possible to get qualitatively similar results. The social goal function often gave different results for the red-

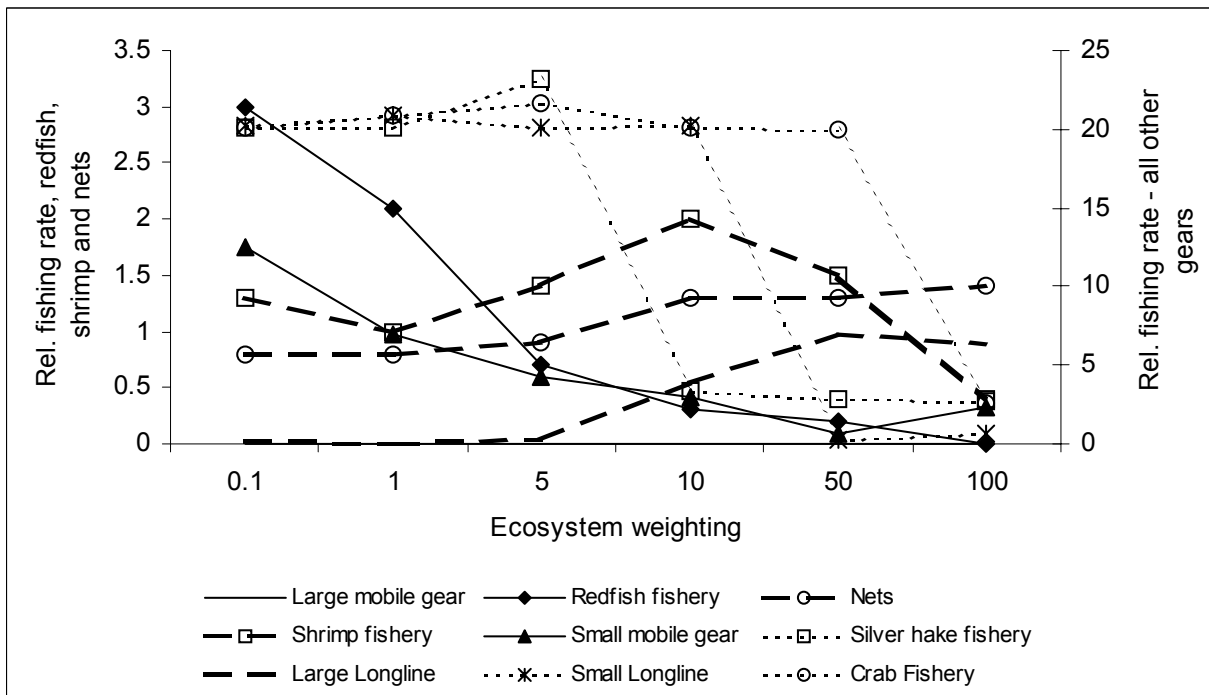

Figure 3 Comparison of fishing policies for a range of ecosystem weightings.

fish fishery and crab fishery in response to different random fishing rates.

## Discussion

In the base runs, the economic and social goal functions did not greatly improve the economic and social scores above the baseline score, whilst the ecosystem score was improved. This may be due to the state of the fishery and ecosystem at the beginning of the simulation when the cod fishery has collapsed and other groundfish stocks are low. It is difficult to improve the economic and social components of the fishery when the resource status is very low. From the ecosystem perspective, there is enormous scope for improvement. When vulnerabilities were assumed to be related to trophic level, there was more scope for improving the economic and social components of the fishery and less likelihood of improving the ecosystem component.

The model performed better (higher scores were obtained from the optimisations, and higher ratios of  $B_{\text{end}}:B_{\text{start}}$ , higher catches) when vulnerabilities were directly related to the trophic level and feeding time of all groups except juveniles were set to zero. These options should be further investigated in order to determine whether they could give a better fit of the model to time series data, and whether they could improve other aspects of model performance.

The data for the social goal function was based on the authors' judgement. The socio-economic data (except price data) were also based on judgement (*see above*). The analyses should be re-run based when the base Ecopath model is finalised and this data becomes available.

## References

- Bundy, A., Lilly, G. and Shelton, P.A. 2000. A mass balance model of the Newfoundland-Labrador Shelf. Can. Tech. Rep. Fish. Aquat. Sci. 2310.
- Liew, D. 1997 Trends in the landed value and participation in the Maritime regions fisheries. DFO Fisheries Status Report 97/E.
-



# The Use of Ecosystem Models to Investigate Multispecies Management Strategies for Capture Fisheries: Report on Southern Benguela Simulations

**Lynne Shannon**

*Resource Assessment and Modelling Section  
Marine And Coastal Management, South Africa*

## Abstract

Fishing strategies which best achieved specified objectives were investigated using an Ecosim model of the southern Benguela ecosystem for 1990-1997. Value of landed catch was maximized when purse seine, demersal trawl and jig fishing effort was increased, although many stocks collapsed. Numbers of jobs were maximized when the demersal, longline and jig fisheries were expanded, again causing stock collapses. There is little clarity in how to optimize ecosystem importance, or what it means in an ecosystem context. A combined, compromise objective was evaluated, which involved weighting the primary objectives to search for a fishing strategy which came closest to simultaneously meeting all defined objectives. Modelling suggests that the optimal compromise fishing strategy is that in which catches by the squid jig fishery are optimized. However, the way in which an ecosystem is presumed to function can have major implications for the choice of the optimal fishing strategy under certain objectives. Further, differences in the nature of control in the ecosystem also affect how error in the management system feeds back into the ecosystem; results obtained showed greater variability between scenarios under the "closed loop" simulations when vulnerabilities are 0.7 than when wasp-waist control or vulnerabilities of 0.4 are assumed.

## Introduction

Two mass-balanced ecosystem models have been developed for the southern Benguela ecosystem. One described the system in the period 1980-1989, the other 1990-1997 (Jarre-Teichmann *et al.* 1998, Shannon and Jarre 1999). The latter is the one used for purposes of this workshop, and has been updated to include discard data from S. Hart (unpublished data from SANCOR Observer Programme, Ph.D. in prep.).

The area modeled extends from the Orange River Mouth (about 29°S) to East London (28°E), offshore to approximately the 500-m depth contour, covering an area of 220 000 km<sup>2</sup>. 31 living groups are modeled (Fig. 1) and six fisheries are considered separately: i) purse

seine, ii) midwater trawl, iii) demersal trawl, iv) line v) long line and vi) other (includes beach seine, gill net, handline, squid jig fishery, recreational fishery). The most valuable commercial species are shallow- and deep-water hake, constituting 26% of the total catches in the southern Benguela during the period 1990-1997. They are caught in demersal trawls, the line and the longline fisheries. There is little room for expansion of the demersal fishery above present levels. Most linefish stocks are currently overexploited and cause for concern. Owing to large fluctuations in anchovy and sardine stock sizes, the pelagic fishery is the most dynamic of all in this region.

During the 1980s, anchovy was the dominant small pelagic fish in the southern Benguela upwelling system. By the 1990s, the size of the anchovy population had decreased and populations of sardine, redeye, horse mackerel and both species of hake had increased in size. Summed biomasses of small pelagic fish (anchovy sardine, redeye, juvenile horse mackerel and other small pelagic fish) increased from 2.62 million tons in the 1980s to 2.80 million tons in the 1990s.

In the 1990s, total biomass and many total flows through the southern Benguela upwelling system were larger than in the 1980s (Table 1), and many properties measuring system maturity were also larger (Shannon thesis in prep.).

## Sensitivity analysis

Simulations in which variability about input parameters were investigated showed that the models of the southern Benguela system during the 1980s and 1990s were both tightly fitted and that there was little room for allocating values to parameters that were much different from those used in original models (Shannon thesis in prep.). Maximization of biomass obtained by varying parameters within defined limits gave total system biomasses only 10% (1980s) and 15% (1990s) above those used in the original models, indicat-

**Table 1.** Comparison of summary statistics of the Southern Benguela upwelling system for the 1980s and 1990s. Flows are in t.km<sup>-2</sup>.y<sup>-1</sup>, biomass in t.km<sup>-2</sup>. (After Shannon, thesis in prep.).

	1980s	1990s
Total biomass (excluding detritus)	221	231
Sum of all consumption	17 230	18 831
Sum of all exports	2 559	1 698
Sum of all flows to detritus	8 771	8 496
Total system throughput	37 975	39 304
Sum of all production	16 233	16 638
Sum of all respiratory flows	9 416	10 279
Total net primary production	11 974	11 977
Total catches	3.04	2.48
Mean trophic level of the fishery	4.74	4.80

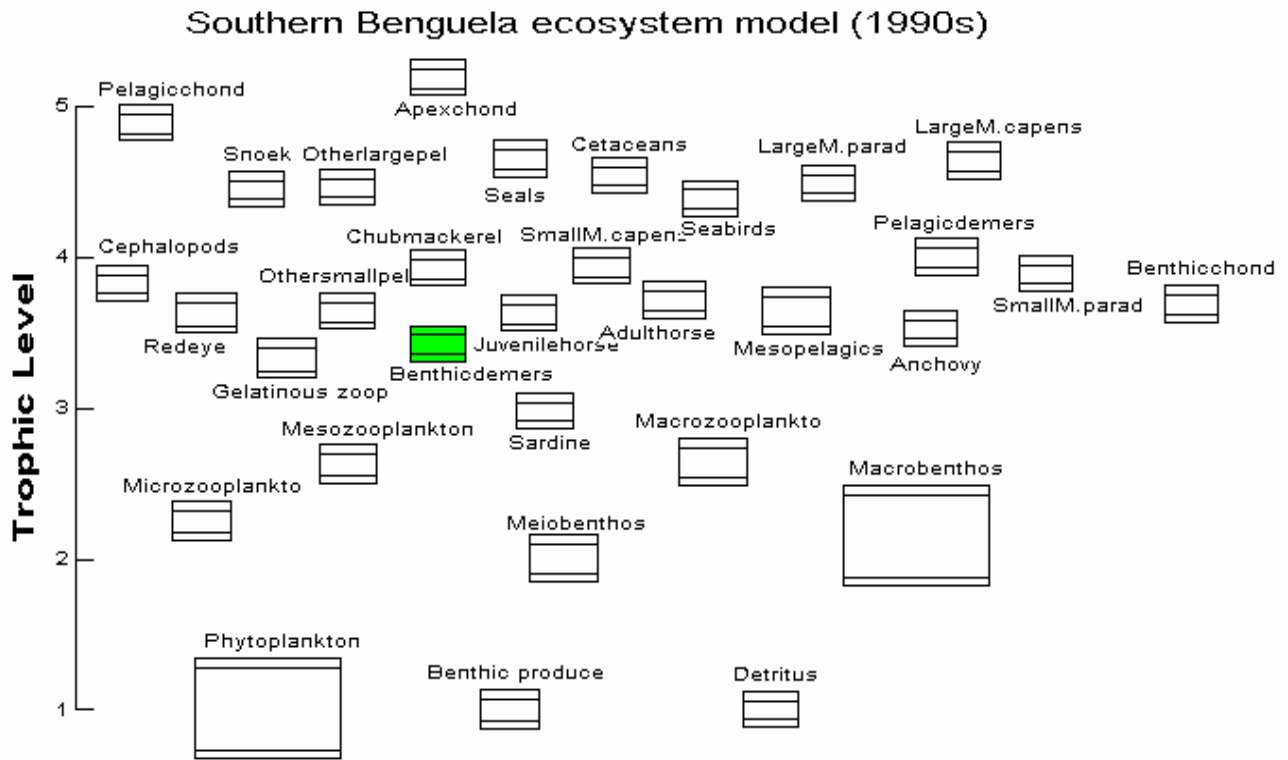

**Figure 1** Diagram of components of the southern Benguela ecosystem model for 1990-1997, arranged according to trophic level.

ing that the system is fairly well constrained.

*Exploring vulnerability settings*

Simulations were explored in which “flow control”, defining the vulnerability of a prey species to its predators, was changed to investigate top-down, bottom-up and wasp-waist flow control between small pelagic fish and their predators and prey in the southern Benguela system (Shannon *et al.* 2000, Cury *et al.* 2000, Shannon thesis in prep.).

Bottom-up control of small pelagic fish by zooplankton prey was found to dampen effects of altered fishing. Under wasp-waist control, assuming small pelagic fish control both their zooplankton prey (top-down) and their predators (bottom-up), vigorous effects of altered fishing propagated through the system. Therefore under bottom-up flow-control, heavier fishing on certain groups may be sustainable, whereas under another scenario e.g. wasp-waist control, fisheries may crash.

Wasp-waist control is believed to best describe the control of flows between groups in the southern Benguela (Cury *et al.* 2000).

*Exploring optimal fishing strategies: Methods*

A new routine in Ecosim was used to search for

theoretical fishing strategies that would optimize economic value, number of jobs (social value) or ecosystem structural importance, or a balance of all three. Values of landed catches (Stuttaford 1999) and estimates of fishers and land-based workers (Cochrane and Payne 1998) were additional data required for this investigation (Tables 2 and 3). It should be noted that estimates of costs related to the various fisheries in this system were not accessible at the time of the workshop, so optimization of economic value was simply based on the selection of fishing strategies that optimized the total value of the landed catches. Numbers of jobs per fishery were estimated as the sum of fishers and jobs ashore.

Ecosystem structure was modeled in two ways – initially, for each ecosystem component, the ratio of ideal biomass ( $B_{ideal}$ ) to current biomass ( $B$ ) could be selected, and a relative importance value allocated. Anchovy, sardine and seabirds were considered to be at levels below pristine states,

**Table 2.** Estimates of jobs per unit catch in the six fisheries of the southern Benguela.

Fishery	Jobs/(catch t.km <sup>-2</sup> )
Purse seine	0.015
Midwater trawl	0.033
Demersal trawl	0.033
Line	0.428
Longline	0.4
Other (rec', squid jig, handline)	0.355

**Table 3.** Landed values (Rands/ton) of fish in the southern Benguela (based on estimates for 1997 in Stuttaford 2000). Derm = Demersal; Mid. = Midwater

Group	Purse seine	Mid. trawl	Dem. trawl	Line	Long-line	Other
Anchovy	408					
Sardine	430					
Redeye	408					
Other small pelagic fish	408					
Chub mackerel	430		1476			
Juvenile horse mackerel	430					
Adult horse mackerel		1340	1340			
Mesopelagic fish	430					
Snoek			2268	4000		4000
Other large pelagic fish			6464	6464		6464
Cephalopods			4930			17000
Small <i>Merluccius capensis</i>			1944			
Large <i>M. capensis</i>			3466		6000	3466
Small <i>M. paradoxus</i>			1944			
Large <i>M. paradoxus</i>			3466		6000	3466
Pelagic-feeding demersals			1305			
Benthic-feeding demersals			4411		10000	
Pelagic-feeding chond.				1090		
Benthic-feeding chond.			465		456	456

and  $B_{ideal}/B$  values of 1.5, 2.0 and 1.25 were allocated respectively, equivalent to the larger anchovy and seabirds abundances of the 1980s and sardine abundance comparable to that of anchovy. All groups were given equal relative importance (unity). This method was in place when strategies optimizing economic and social values were assessed. In the second, revised method, ecosystem structure was modeled by giving relative weightings to each group, the default being equivalent to B/P ratios, although alternative relative weightings were permitted. The second method was used in testing for optimal ecosystem structure without optimizing economic or social values, and also in simulations to obtain a balance between the three objectives. For comparative purposes, the first method was also used in the trade-off optimization procedure.

Optimal fishing strategies were explored by giving a relative weighting of 1 to the objective being tested (economic value, social value or ecosystem structure) and a value of 0.0001 to the other two. Open loop simulations gave biomasses, catches and values per group, and once I was satisfied that a certain strategy was optimal under the chosen conditions (i.e. that beginning open loop

**Table 4.** Optimal fishing strategies over twenty years when economic value was optimized. Catch and value are reported as the ratio of those at the start (year 0-2): those at the end of the simulation period (year 22).

	Wasp-waist		Vulnerability=0.4		Vulnerability=0.7	
	Catch	Value	Catch	Value	Catch	Value
Purse seine	2.02	2.00	2.17	2.14	5.50	5.42
Midwater trawl	0.00	0.00	0.00	0.00	0.00	0.00
Demersal trawl	4.61	3.02	5.87	2.89	5.54	3.80
Line	0.70	0.52	0.21	0.05	0.17	0.04
Longline	0.56	0.76	0.19	0.23	0.28	0.43
Other	27.05	34.80	29.48	38.15	26.2	34.18
Total	3.41	6.11	4.05	6.37	5.61	7.01

simulations from base Fs, current Fs to avoid plateauing, and from random Fs, all pointed to common optimal fishing strategies), a closed loop simulation of 100 runs was used to produce projected plots of biomasses of each group over time. Default settings were adopted. Wasp-waist flow control was assumed for simulations, but alternative vulnerability settings were also tested. A period of 22 years was modeled. In the first two years, Fs were assumed to be those in the base model (1990-1997). The model

was then used to find optimal constant Fs for each of the six fisheries over the next 20 years, given the three objectives or a trade-off between them.

### Exploring optimal fishing strategies: Results and Discussion

#### Optimizing economic value (landed values):

In a wasp-waist system, optimal economic value of the catch was obtained by increasing catches of the purse-seine fishery twofold and increasing demersal trawl catches almost five-fold (Table 4).

In particular, catches of cephalopods were increased by a factor of 27, largely through expanding the jig fishery ("other" gear category). This strategy promoted heavier fishing on the predators of cephalopods, such as hakes (demersal trawl) and seals, and on species competing with cephalopods for food, such as anchovy and sardine (purse seine fishery), resulting in macrozooplankton, anchovy, sardine, chub mackerel, horse mackerel, snoek and hakes being eliminated from the system, and seals severely reduced (Fig. 2). The optimal economic strategy yielded a value

6.11 times the original value of landings in the 1990-1997 model (Table 4). Higher net values were obtained from open loop simulations (without assessment) than means achieved over the 100 closed loop simulation trials (Table 5).

A uniform vulnerability setting of 0.7 gave similar results to those assuming wasp-waist flow control. By comparison, when vulnerabilities were uniformly set to 0.4 for all groups, macrozooplankton did not crash, pelagic demersal fish became more abundant, and the increase in cetacean biomass was dampened. There was greater variability between the 100 runs when vulnerabilities were 0.7 than in the wasp-waist or 0.4 vulnerability simulations. This was also true when social, ecosystem and trade-off objectives were optimized

*Optimizing employment in the fisheries (no. of jobs):*

For all three vulnerability settings, fishing strategies optimizing employment caused stocks of chub mackerel, snoek, other large pelagic fish and hakes to crash because fishing using demersal trawls was 4-5 times heavier, fishing using “other” gear was increased and in most cases, the longline fishery was expanded. Snoek and other large pelagic fish were depleted (Fig. 3) because

**Table 5.** Open versus closed loop values when optimizing landed economic values – differences indicating the “cost” of improving assessment estimates. Wasp-waist control was assumed. \* =(approach used at workshop)

Criteria	Open loop	Closed loop
Net economic value	1.5x10 <sup>6</sup>	8.2x10 <sup>5</sup>
Social/employment value	2.8x10 <sup>5</sup>	1.4x10 <sup>5</sup>
Ecosystem stability value *	-7.6x10 <sup>3</sup>	-6.0x10 <sup>3</sup>
Overall value	8.76	4.66

they are targeted by the line fishery, having a high employment value. Similarly, hakes are caught in both the demersal and longline fisheries, the latter employing many people relative to the catch size (Table 2).

For vulnerabilities of 0.4, in half the cases simulating optimal fishing strategies in the open loop from random Fs, a fishing strategy similar to that obtained for vulnerabilities of 0.7 was obtained, in the other half, these differed (Table 6). Wasp-waist control and vulnerabilities of 0.4 produced similar closed loop versus open loop results; all values were larger in the open loop simulations. By comparison, closed loop simulations gave larger ecosystem structure values than open loop

simulations when vulnerabilities were 0.7, suggesting that this vulnerability setting may cause instabilities in the system (Table 7).

*Optimizing ecosystem structure:*

When relative weightings were assumed equivalent to the B/P ratios for each group, and wasp-waist control was assumed, the “optimal” fishing strategy in terms of ecosystem objectives had detrimental effects on the ecosystem; macrozooplankton, chub mackerel, snoek and hakes all collapsed (Fig. 4). Therefore, numerous different selections of relative ecosystem weightings were tested in attempts to reach a more balanced system in which these stocks were not depleted. It was found that either horse mackerel or other large pelagic fish (including snoek) were favoured, never both simultaneously.

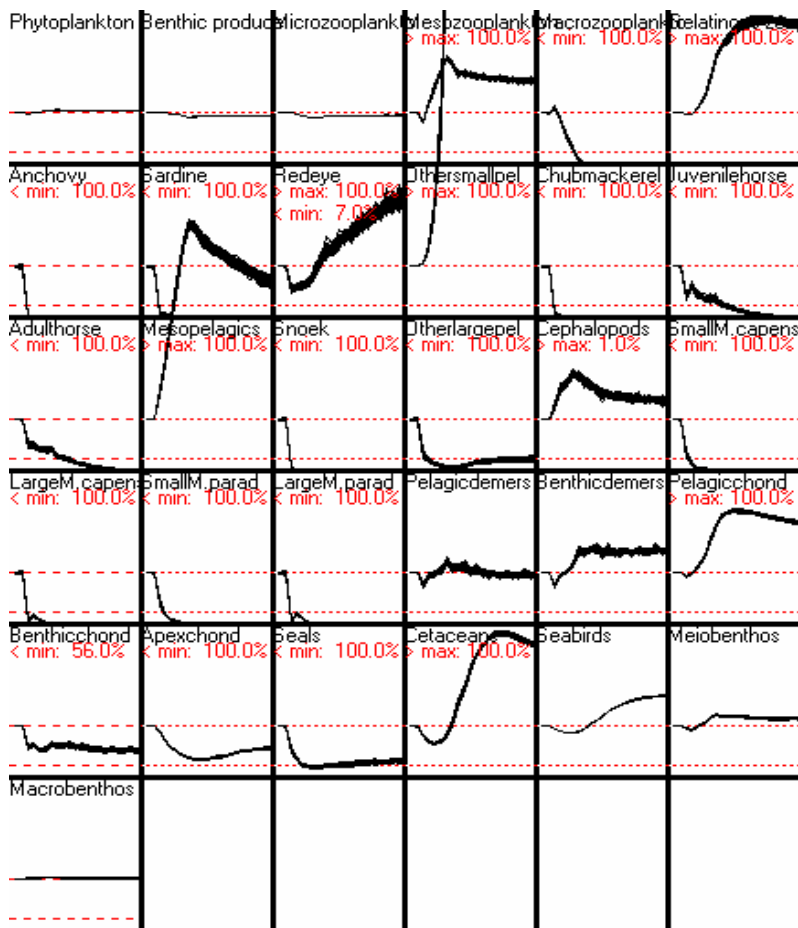

**Figure. 2** Biomass plots (over the 22 year simulation period) of 100 closed loop simulations optimizing landed catch values (Rands/ton) in the southern Benguela system. Wasp-waist control was assumed.

**Table 6.** Optimal fishing strategies over twenty years when employment was optimized. Catch and value are reported as the ratio of those at the start (year 0-2): those at the end of the simulation period (year 22). \* assuming vulnerabilities of 0.4, typifying half the simulations and differing from those when vulnerabilities=0.7.

	Wasp-waist		Vulnerability=0.4*		Vulnerabil-	
	Catch	Value	Catch	Value	Catch	Value
Purse seine	0.05	0.05	0.49	0.49	2.96	2.97
Midwater trawl	0.96	0.96	0.79	0.79	0.38	0.38
Demersal trawl	3.73	2.84	5.66	3.28	5.45	4.25
Line	3.84	3.47	0.86	0.19	1.07	0.24
Longline	2.87	4.35	0.87	1.16	4.13	6.86
Other	25.05	29.41	26.59	33.34	28.38	36.4
Total	2.05	5.39	3.06	5.90	4.3	7.31

**Table 7.** Open versus closed loop values when optimizing employment.

Criteria	Wasp-waist control		Vulnerabilities of 0.4	
	Open loop	Closed loop	Open loopx10 <sup>5</sup>	Closed loopx10 <sup>3</sup>
Net economic value	1.3 x10 <sup>6</sup>	7.8 x10 <sup>5</sup>	1.8 x10 <sup>5</sup>	7.6 x10 <sup>5</sup>
Social/employment value	2.6 x10 <sup>5</sup>	1.5 x10 <sup>5</sup>	3.1 x10 <sup>5</sup>	1.2 x10 <sup>5</sup>
Ecosystem stability value (approach used at workshop)	-1.6x10 <sup>3</sup>	-1.5x10 <sup>3</sup>	-853.61	-893.05
Overall value	12.84	7.71	15.37	5.95

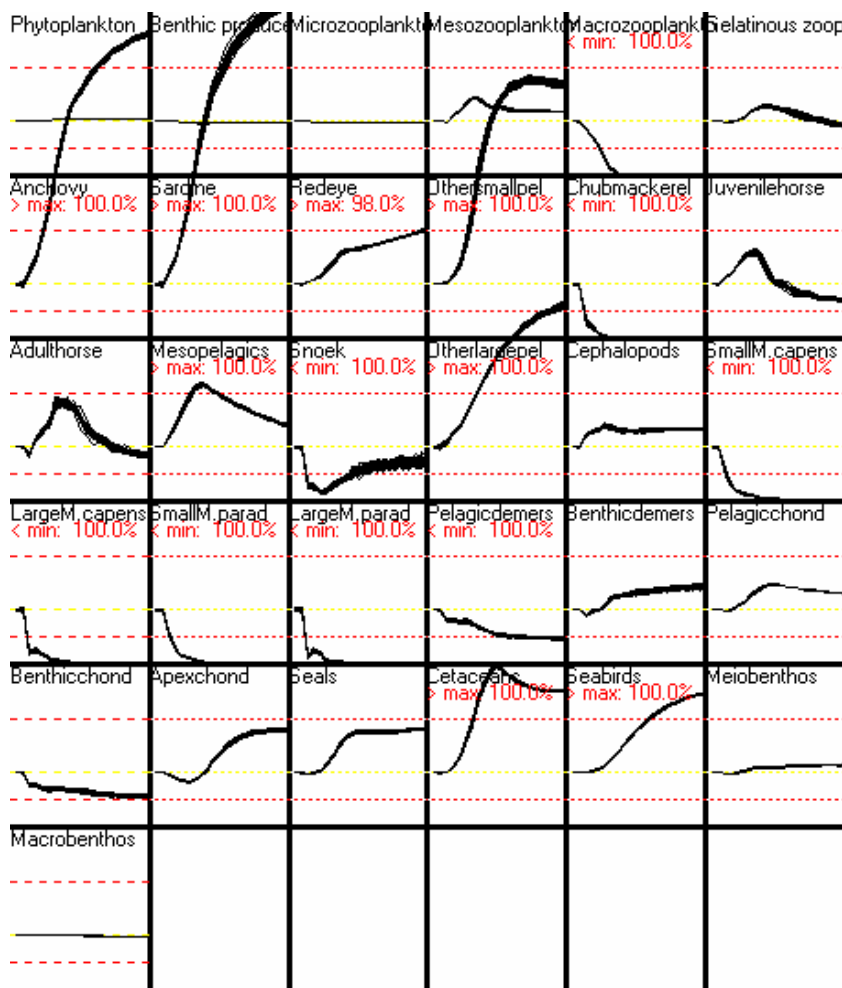

**Figure. 3** Biomass plots (over the 22 year simulation period) of 100 closed loop simulations optimizing employment (jobs/ton caught) in the southern Benguela system. Wasp-waist control was assumed.

It was felt that the scenario in which snoek and other large pelagic fish were not reduced was the better option for investigating the trade-off strategy because these fish are highly valuable and form an important part of fisheries with high employment values. Therefore, the B/P defaults were accepted for most groups except for macrozooplankton and small hakes (increased to 1.0) and large hakes (increased to 1.5). Simulations assuming wasp-waist control and vulnerabilities of 0.4 were similar (Table 8), favouring snoek and other large pelagic fish, but greatly reducing horse mackerel abundance (Fig. 5). By comparison, vulnerabilities of 0.7 caused the system to revert to a state similar to that when weightings were set according to B/P ratios.

Closed loop simulations showed that vulnerabilities of 0.7 produced larger economic, social and ecosystem structural values than the other two flow control types. In all cases, identical ecosystem and overall values in open and closed loop simulations indicated that there were no additional costs or benefits to optimizing net ecosystem values by improving stock assessments. This is in contrast to strategies in which either economic or social objectives are optimized (Tables 5 and 7).

*Towards a trade-off between optimizing economic value, social value and importance of ecosystem structure:*

Extensive testing of various different weightings of economic:social:ecosystem values was undertaken in an attempt to find a trade-off fishing strategy that optimized all three objectives.

To minimize stock collapses in the southern Benguela, ecosystem structure required a much larger weighting than economic or social values.

**Table 8.** Optimal fishing strategies over twenty years when optimal ecosystem structures were attempted using the revised (second) method. Catch and value are reported as the ratio of those at the start (year 0-2): those at the end of the simulation period (year 22).

	Wasp-waist		Vulnerability=0.4		Vulnerability=0.7	
	Catch	Value	Catch	Value	Catch	Value
Purse seine	0.10	0.10	0.08	0.08	0.12	0.12
Midwater trawl	0.17	0.17	0.32	0.32	2.03	2.03
Demersal trawl	0.06	0.07	0.07	0.08	3.31	2.24
Line	0.21	0.21	0.13	0.13	0.18	0.24
Longline	1.54	1.55	1.60	1.61	0.30	0.40
Other	0.72	0.63	0.47	0.41	0.76	0.73
Total	0.10	0.16	0.09	0.14	1.52	1.61

**Table 9.** Open versus closed loop values when optimizing ecosystem structure.

Criteria	Wasp-waist control		Vulnerabilities of 0.4		Vulnerabilities of 0.7	
	Open loop	Closed loop	Open loop	Closed loop	Open loop	Closed loop
Net econ. value	4.1 x10 <sup>4</sup>	3.0x10 <sup>4</sup>	3.7x10 <sup>4</sup>	2.8x10 <sup>4</sup>	4.8x10 <sup>5</sup>	2.9x10 <sup>5</sup>
Social/employ.	8.3 x10 <sup>3</sup>	5.8x10 <sup>3</sup>	6.5x10 <sup>3</sup>	4.7x10 <sup>3</sup>	2.2x10 <sup>4</sup>	1.4x10 <sup>4</sup>
Ecosystem stability (as at workshop)	1.0x10 <sup>3</sup>	1.0x10 <sup>3</sup>	9.8x10 <sup>2</sup>	9.8x10 <sup>2</sup>	1.2x10 <sup>3</sup>	1.2x10 <sup>3</sup>
Overall value	1.21	1.21	1.17	1.17	1.45	1.45

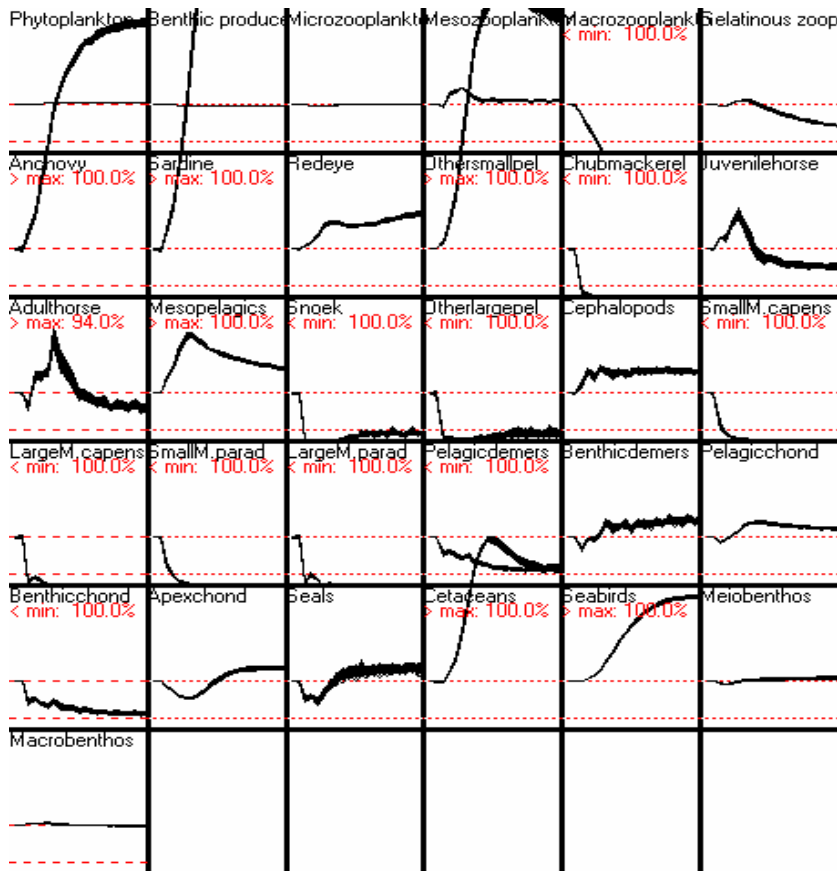

**Figure 4** Biomass plots (over the 22 year simulation period) of 100 closed loop simulations optimizing ecosystem structure in the southern Benguela system when groups were weighted according to their B/P ratios. Wasp-waist control was assumed

Even under a weighting of 1:1:10, and assuming the conservative vulnerability setting of 0.4, chub mackerel, snoek, other large pelagic fish and hakes were eliminated from the system. Therefore a weighting of 1:1:25 for economic: social :ecosystem was adopted.

Using the first method of evaluating ecosystem importance, catch was increased by up to 50% and economic value between two and three-fold when ecosystem structure was optimized (Table 10). Catches, especially of cephalopods, were increased in the “other” gear fisheries and abundances of most groups increased or at least remained constant (Fig. 6).

Two sets of optima were obtained using the second method to assess ecosystem structure (weighting according to B/Ps with increased values for macrozooplankton and hakes) and to find a trade-off between the three objectives. In the first, catches were doubled and economic values increased between five- and six-fold when wasp-waist control and vulnerabilities of 0.7 were assumed (Table 11). Similarly, in some simulations where vulnerabilities were proportional to trophic levels, and which began using random Fs, the same optimal strategy was found (Fig. 7).

Such strategies caused collapses of chub mackerel, snoek and hakes by expansion of the demersal trawl fishery to four or five times its original size. These consequences differed from those under optimal trade-off fishing strategies obtained when vulnerabilities of 0.4 were assumed, and in some cases when vulnerabilities were proportional to trophic levels (Table 11).

**Table 10.** Optimal fishing strategies over twenty years when optimal ecosystem structures were attempted using the first method (ecosystem importance) and weighting economic:social:ecosystem importance as 1:1:25. Catch and value are reported as the ratio of those at the start (year 0-2): those at the end of the simulation period (year 22).

	Wasp-waist		Vulnerability=0.4		Vulnerability=0.7	
	Catch	Value	Catch	Value	Catch	Value
Purse seine	0.99	0.99	0.23	0.23	1.47	1.47
Midwater trawl	3.07	3.07	1.53	1.53	0.33	0.33
Demersal trawl	1.13	1.16	1.63	1.5	1.12	1.17
Line	0.97	0.91	0.62	0.57	0.44	0.37
Longline	1.37	1.38	1.89	1.91	1.58	1.59
Other	16.79	17.23	16.77	18.61	16.53	18.18
Total	1.27	2.88	1.07	3.12	1.49	3.01

**Table 11.** Optimal fishing strategies over twenty years when a trade-off between economic value, employment value and ecosystem structure was achieved by relative weighting of these three objectives: 1:1:25 using the revised method of ecosystem weighting. Catch and value are reported as the ratio of those at the start (year 0-2): those at the end of the simulation period (year 22).

	Wasp-waist		Vuln.=0.4		Vuln.=0.7		Vuln. α TL	
	Catch	Value	Catch	Value	Catch	Value	Catch	Value
Purse seine	0.00	0.00	0.00	0.00	0.00	0.00	0.01	0.01
Midwater trawl	0.21	0.21	0.28	0.28	0.23	0.23	0.02	0.02
Demersal trawl	3.75	2.93	0.01	0.01	4.65	3.95	0.01	0.01
Line	0.23	0.28	0.03	0.03	0.10	0.12	0.03	0.03
Longline	0.75	1.11	30.43	30.78	0.34	0.57	27.78	28.15
Other	25.31	28.12	19.16	18.16	28.59	33.59	21.05	20.66
Total	1.95	5.03	0.36	2.42	2.37	6.28	0.38	2.65

Under these conditions, catches were reduced to a third of original levels and economic values increased between two- and threefold by large increases in the valuable longline and “other” fisheries and a reduction in the demersal fishery. The trade-off in the second set of strategies was a severe reduction in horse mackerel stock size (Fig 7).

In all cases using the second ecosystem approach, the purse seine fishery was closed, allowing anchovy and sardine stocks to grow, whereas under the first ecosystem method, a healthy purse seine fishery was maintained. However, both methods revealed a common goal of expanding the economic and socially valuable “other” gear fisheries, in particular to enhance catches of cephalopods. This

was achieved by increasing cephalopod biomass by a factor of between 15 and 36, in particular through a reduction in its predators (hakes and seals).

There were no differences between open and closed loop simulation values when wasp-waist control was assumed (Table 12), suggesting little benefits in improving estimates of stocks and effort regulation. Overall values for closed loop simulations were larger in the trade-off simulations than in those in which only one objective was optimized at a time (Table 12 cf. Tables 5,7 and 9).

Vulnerability settings of 0.7 gave a net ecosystem stability value that was lower in open loop simulations than in closed loop simulations incorporating variability about stock assessments and methods of effort control.

Assuming vulnerabilities of 0.7 may give rise to instabilities in the system and unrealistic optimal fishing strategies.

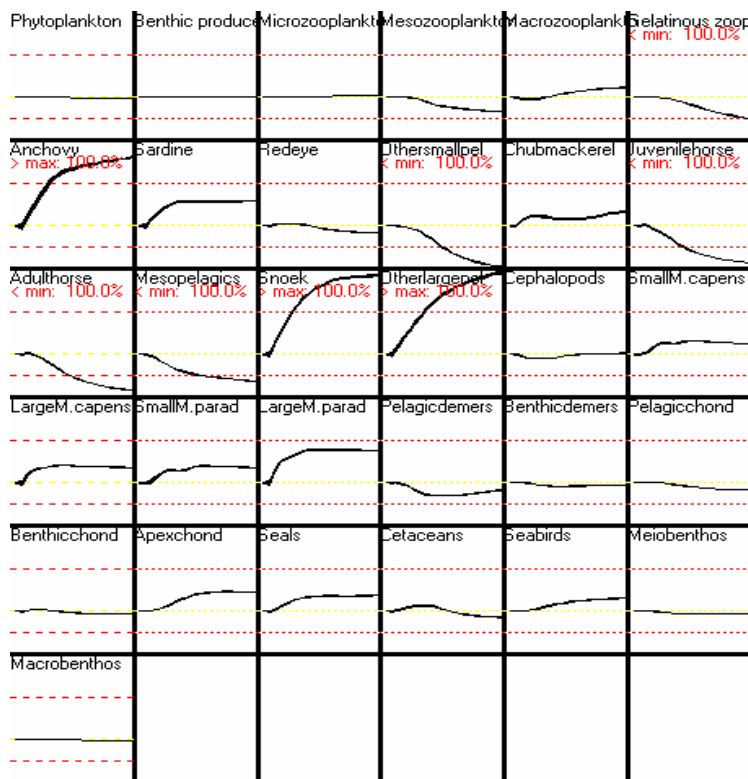

**Figure 5** Biomass plots (over the 22 year simulation period) of 100 closed loop simulations optimizing ecosystem structure in the southern Benguela system when groups were weighted according to their B/P ratios, with the exceptions of macrozooplankton and small hakes (set to 1) and large hakes (set to 1.5). Wasp-waist control was assumed.

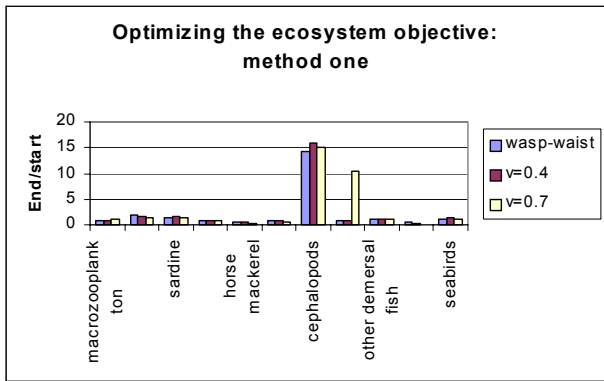

**Figure. 6** Comparing end/start biomasses of major groups in the southern Benguela system under three vulnerability settings, when the first method of optimizing ecosystem importance was used to find a trade-off between economic, social and ecosystem objectives by relative weightings 1:1:25.

**Conclusions**

(i) Fishing strategies that optimize economic value or employment are understandable and can be explained.

(ii) These simulations often give rise to extreme alternative fishing policies and highlight the importance of carefully defining the objectives for setting a new fishing strategy in a particular system.

(iii) The way in which a system is presumed to function (vulnerability settings) can have major implications for the choice of optimal fishing strategy under certain objectives.

(iv) In contrast to optimizing economic or social values, there is not as much clarity in how to optimize ecosystem stability or structure. This is partly because the latter includes some subjectivity in the selection of groups to be given higher weightings, or even to be “monitored” when testing for reasonable optimal strategies.

(v) The trade-off fishing strategy selected depends on how much relative weighting is given to each objective i.e. it is somewhat subjective and depends on the importance given to a stable ecosystem structure.

(vi) The 1:1:25 economic: social: ecosystem weighting using the first method to find a trade-off strategy was similar to that using the second ecosystem optimization method in that both

optimized cephalopod catches. This provides confidence in the overall conclusions drawn about theoretical optimization of fishing strategies in the southern Benguela system given specific theoretical objectives.

(vii) When ecosystem structural weightings were considered to be proportional to trophic levels, the optimal trade-off fishing strategy was consistent with those obtained when wasp-waist control and vulnerabilities of 0.4 were assumed. Therefore this general guideline to setting of vulnerabilities is promising.

(viii) The larger variability between the 100 means of closed loop simulations when vulnerabilities were 0.7 than when wasp-waist control or 0.4 vulnerabilities were assumed, suggests that smaller vulnerabilities are probably preferred for the southern Benguela upwelling system. Wasp-waist flow (bottom-up control of predators by small pelagic fish and top-down control of zooplankton by small pelagic fish) gave reasonable results.

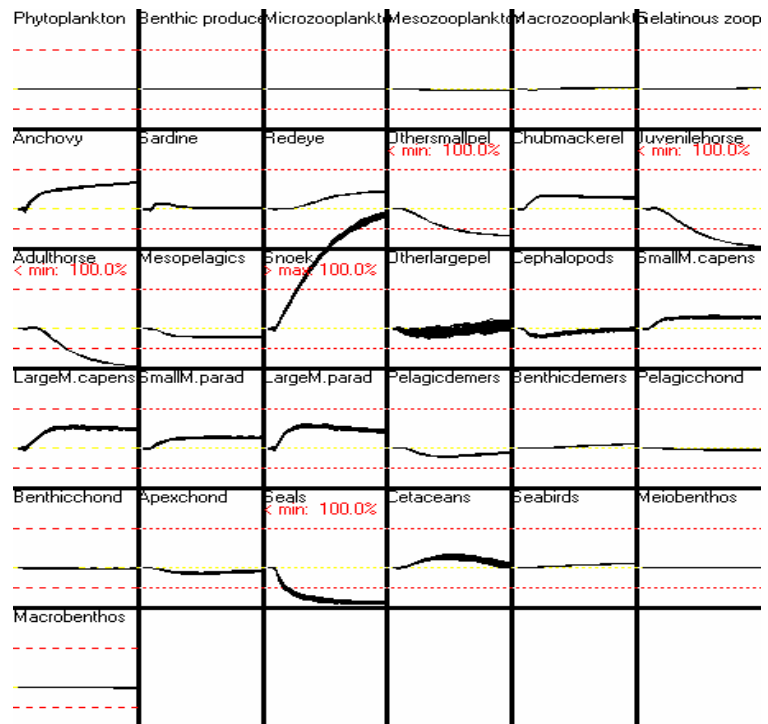

**Fig. 7** Biomass plots (over the 22 year simulation period) of 100 closed loop simulations finding an optimal trade-off between economic, social and ecosystem objectives (weighted 1:1:25) in the southern Benguela system when the revised ecosystem weighting method was used and vulnerabilities were proportional to trophic levels.



**Table 12.** Open versus closed loop values for a trade-off between economic value, social value and ecosystem structure using the revised method of ecosystem weighting. \* = approach used at workshop.

Criteria	Wasp-waist control		Vuln. = 0.4		Vuln. = 0.7		Vuln. $\alpha$ TL	
	Open loop	Closed loop	Open loop	Closed loop	Open loop	Closed loop	Open loop	Closed loop
Net economic value	1.3 x10 <sup>6</sup>	1.3x10 <sup>6</sup>	4.6x10 <sup>5</sup>	3.1x10 <sup>5</sup>	1.6x10 <sup>6</sup>	7.3x10 <sup>5</sup>	4.9x10 <sup>5</sup>	3.3x10 <sup>5</sup>
Social value	2.3x10 <sup>5</sup>	2.3x10 <sup>5</sup>	1.6x10 <sup>5</sup>	1.1x10 <sup>5</sup>	2.8x10 <sup>5</sup>	1.4x10 <sup>5</sup>	1.8x10 <sup>5</sup>	1.1x10 <sup>5</sup>
Ecosyst. stability*	1.1x10 <sup>3</sup>	1.1x10 <sup>3</sup>	9.2x10 <sup>2</sup>	9.2x10 <sup>2</sup>	1.1x10 <sup>3</sup>	1.2x10 <sup>3</sup>	9.3x10 <sup>2</sup>	9.3x10 <sup>2</sup>
Overall value	50.79	50.79	38.38	34.76	56.08	45.66	39.37	35.37

## References

- Cochrane, K.L. and A.I.L. Payne 1998. People, Purses and Power: Developing fisheries policy for the new South Africa. Pages 57-71 in T.J. Pitcher, P.J.B. Hart and D. Pauly (eds) Reinventing Fisheries Management. Kluwer Academic, Dordrecht, Netherlands. 435 pp.
- Cury, P., Bakun, A., Crawford, R.J.M., Jarre-Teichmann, A., Quinones, R.A., Shannon, L.J. and Verheye, H.M. 2000. Small pelagics in upwelling systems: patterns of interaction and structural changes in "wasp-waist" ecosystems. Academic Press, ICES Journal of Marine Science, Symposium Edition 57(3): 603-618.
- Jarre-Teichmann, A., Shannon, L.J., Moloney, C.L. and Wickens, P.A. 1998. Comparing trophic flows in the southern Benguela to those in other upwelling ecosystems. In Pillar, S.C., Moloney, C.L., Payne, A.I.L. and Shillington, F.A. Benguela dynamics: impacts of variability on shelf-sea environments and their living resources. S. Afr. J. mar. Sci. 19: 391-414.
- Shannon, L.J., Cury, P and Jarre, A. 1999. Modelling effects of fishing in the southern Benguela ecosystem. Academic Press. ICES Journal of Marine Science, Symposium Edition 57(3):720-722.
- Shannon, L.J. in prep. Modelling trophic flows through the southern Benguela upwelling system, towards provision of ecosystem management advice. Ph.D. thesis to be submitted - end 2000.
- Stuttaford, M. (ed.) 2000. Fishing Industry Handbook: South Africa, Namibia and Moçambique. Exbury Publications, Cape Town, South Africa. 404 pp.

# Impact of harvesting strategies on fisheries and community structure on the Continental Shelf of the Campeche Sound, Southern Gulf of Mexico

**Francisco Arreguin-Sanchez**  
 CICIMAR, La Paz, Baja California Sur, Mexico

## Abstract

An analysis of harvest strategies for the ecosystem of the Campeche Sound, Southern Gulf of Mexico, was conducted based on a mass-balance model previously published, and making some emphasis on the shrimp fishery, which is strongly depleted. In the ecosystem model four fleets were identified, the shrimp and three artisanal fleets associated with the fishing gear and target species. A time series of estimated biomass (and corrected because of a depensatory effect) and fishing pattern for the shrimp fishery, for the period of 1974 to 1993 was contrasted with Ecosim shrimp-biomass simulation, also involving forcing factors representing one of the main causes for shrimp-biomass depletion. Besides this simulation, seven harvesting strategies were simulated by optimizing different criteria such as economic rent, social (employment) and ecosystem stability, as well as a combination between them. The impact of different strategies on biomass groups, on the uncertainty, and how biomass changes with trophic level was measured. Changes in vulnerability to predation and in the mean trophic level were also explored. Simulations were conducted under different harvesting strategies considering optimization of economic rent, jobs and ecosystem stability criteria combined, as well as the ecosystem stability criterion alone. During such simulations some conditions were modified such as the weighting factors on ecosystem criteria and uncertainty per group; weighting factors for the impact of fleets, and annual changes in catchability per fleet. Simulated biomasses were compared with some fixed levels of biomass as reference points. In general terms most scenarios caused a depletion of some groups below the critical level of 50% of the starting biomass, which was here considered as an undesirable level. Even more sharks tend to disappear during the first years of simulation. A scenario where the ecosystem structure criterion was optimized, shows no depletion of any group. For all the cases, shrimp showed an uncertain behavior during the terminal years of the simulation, always associated with the effect of forcing factors. However, for the scenario optimizing an ecosystem structure criterion, shrimp uncertainty was lower.

## Introduction

The continental shelf of the Campeche Sound on the Southern Gulf of Mexico is a complex ecosystem accounting for the use and exploitation of the natural resources. In this area the oil industry ex-

tracts around 70% of the oil and natural gas produced in the country, and converges with other activities, mainly fisheries and services (mainly transport).

The Campeche Sound has historically been important because of the exploitation of shrimp resources. Before the oil industry was established (early 80's), fishing, and particularly the shrimp fishery, was the center of the regional economy. Landing records show that for many years shrimp was practically the only species exploited; other species did not appear in the statistics. Higher yields were obtained during early 1970's with around 27,000t per year, of which 90% was the pink shrimp (*Farfantepenaeus duorarum*). Currently this fishery is collapsed, with yields close to 3,000t per year. The main problem with this fishery is that recruitment rate has continuously declined since the 1970's, and is highly influenced by environmental factors such as salinity, which has decreased markedly since the mid-80's. Increasing sea surface temperature has reduced stock abundance. In both cases, correlation analysis indicates values above  $r^2=0.7$  (Ramírez-Rodríguez *et al.* 2000). With decrease in the shrimp stock, there has been more targeting of other fish.

The ecosystem approach to explore the impact of harvest strategies is based on a model constructed with Ecopath with Ecosim software (Christensen and Pauly 1992, Walters *et al.* 1997) by Manikchand-Haileman *et al.* (1998), and it is based on information on biomass taken from surveys during the period August 1988 to July 1994. The ecosystem comprises an area of 65,000km<sup>2</sup>, where the shrimp fishery commonly operates with a current fleet size of around 320 boats. In this area, close to the coast, some artisanal fisheries also operate. Recent statistics indicate the existence of more than 4400 boats in the artisanal fleet. Details of the basic data, related to the construction of the model and ecosystem statistics, can be consulted in Manikchand-Haileman *et al.* (1998), while main biomass flows are shown in Figure 1.

**Table 1.** List of strategies.

Strategy	Description
Strategy 1	Leave things under the current tendency. This is taken as the base scenario
Strategy 2	Optimize economic benefits over social and ecological benefits
Strategy 3	Optimize social benefits in terms of jobs
Strategy 4	Optimize ecosystem benefits in terms of ecological quality/conservation
Strategy 5	Optimize economic, social and ecological benefits as an ideal scenario
Strategy 6	Optimize economic and social benefits
Strategy 7	Optimize social and ecological benefits
Strategy 8	Optimize economic and ecological benefits

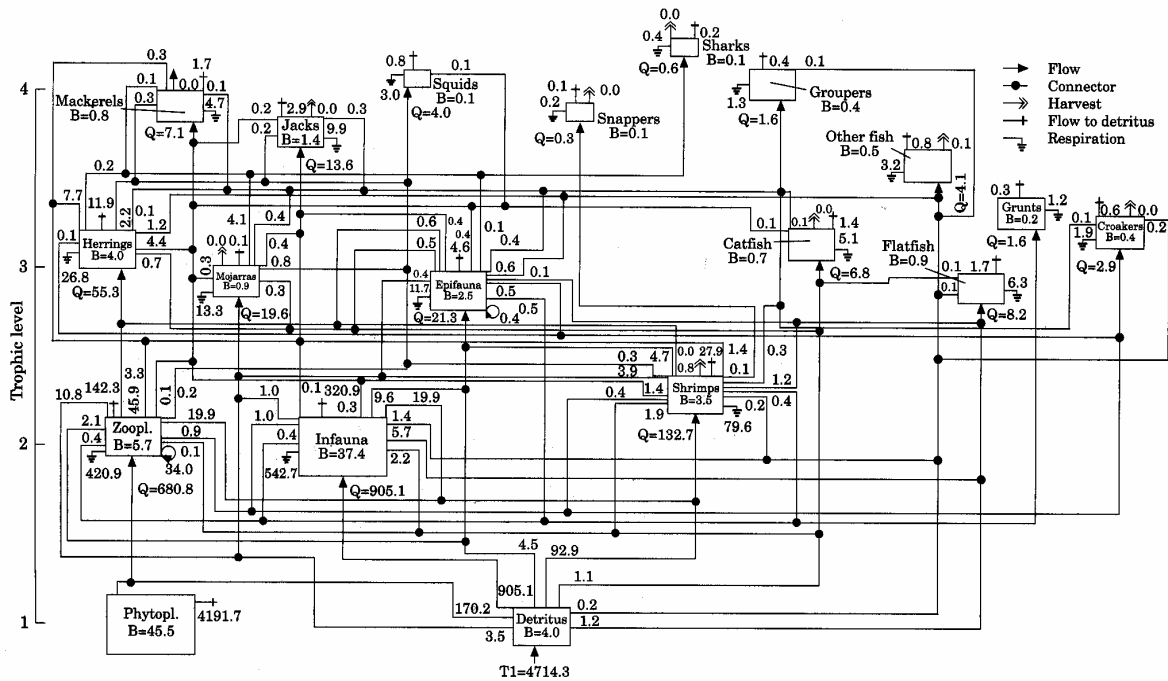

**Figure 1** Biomass-flow diagram for the ecosystem of the continental shelf of the Campeche Sound, Mexico. Biomass (B), Consumption (Q) and fishery harvest are in  $\text{g m}^{-2}$  wet weight; all flows are in  $\text{g m}^{-2} \text{ year}^{-1}$  (taken from Manikchand-Haileman *et al.* 1998).

In 2000, the National Institute of Fisheries in Mexico met a panel of experts to analyze the situation of the shrimp fishery in the Campeche Sound. The main conclusions were classified under three major issues: the impact of the fishery (overcapitalization, overfishing), the quality of the environment (which in some areas has been altered by natural and human-induced causes), and social aspects (loss of employment and inability to control illegal fishing). The aim of this contribution is to test harvesting strategies of the fisheries of Campeche Sound in the context of the ecosystem, and to evaluate the impact of potential management policies.

## Material and Methods

The previously published model contains 11 groups: fishes, sharks, shrimp, squids, epifauna, infauna, zooplankton, phytoplankton and detritus. There are two types of fisheries, shrimp trawling and artisanal fisheries. The latter was di-

vided in three groups by target species and fishing gear. The *artisanal-demersal fleet* mostly uses short longlines and hand-based hooks; this fleet target on groupers, snappers among others. The *artisanal-pelagic fleet* mostly uses gillnets to catch mackerels, jacks, and hook-lines for sharks; and the *beach seine fishery*, which operates in some localities exploiting a number of species.

Harvesting strategies were tested for the optimization of three major criteria, *economic benefits* in terms of net profits, *social benefits* in terms of *employment* (*social benefits*) generated by the fisheries, and *ecosystem benefits* in terms of maintenance of the stocks (ecosystem stability). Under this context eight strategies were tested as in Table 1.

### Preparing the base scenario (Strategy 1)

Catch values were obtained from statistical records reported by the ministry of fisheries (SEMARNAP, 1998) as landed prices. Costs were represented as proportions as in Table 2.

Time series were used to calibrate simulated biomasses. In this case, the available data corresponded to harvest rates and estimated biomasses for the shrimp fishery which were previously estimated through a non-equilibrium biomass dynamic model (Schaefer 1957, Hilborn and Walters 1992) and corrected by non-compensatory effects

**Table 2.** Costs per fleet.

Fleet	Fixed cost (%)	Effort related cost (%)	Sailing related cost (%)	Profit (%)
Shrimp	5	40	10	55
Art DEM HL	2	20	1	77
Art PEL	2	30	3	65
Art Beach Seine	2	10	0	88

(unpublished data<sup>1</sup>). Time series cover the period of 1974 to 1994.

A significant correlation with forcing factors and shrimp abundance were found, particularly sea surface temperature and salinity, being the last an inverse relationship. Here salinity was incorporated as forcing factor affecting shrimp group.

Vulnerabilities to predation were assumed to be  $v = 0.3$ , representing mixed control of flows of biomass by predators and preys.

For all strategies the mean trophic level of the ecosystem, MTLE, was computed based on simulated biomasses:

$$MTLE = \left( \sum_{i=1}^n B_i TL_i \right) / \sum_{i=1}^n B_i$$

where  $B_i$  = biomass of the stock  $i$ , and  $TL_i$  = the mean trophic level of the stock  $i$ .

**Testing Strategies**

Applying specific objective functions, all the strategies were tested; for this, a very low weight was assigned to the undesirable criteria, and unit weight to the objective criteria. A null ecological weight (zero) was assigned to each group, with exception of shrimp, where the weight was unity. For the social criteria, defined as the Job/Catch ratio, the assigned values for each fishery were as follows: shrimp=0.5, art-DEM HL=1.7, art-PEL=1.7 and art-beach seine=2.0.

In a trophic model, vulnerability to predation can be an important factor defining simulated biomass trajectories. Arreguín-Sánchez (2000) showed that modelled octopus biomass is unstable with low values of vulnerability to red grouper on the continental shelf of Yucatan. The same occurs under high vulnerabilities combined with high fishing pressure. In the present case, the exploration of the vulnerability parameter is useful because of the stress to which shrimp stock is currently subjected. In addition to the EwE default value ( $v = 0.3$ ), three scenarios were tested with values  $v = 0.2$ ,  $v = 0.4$  and  $v = 0.7$ , where lower

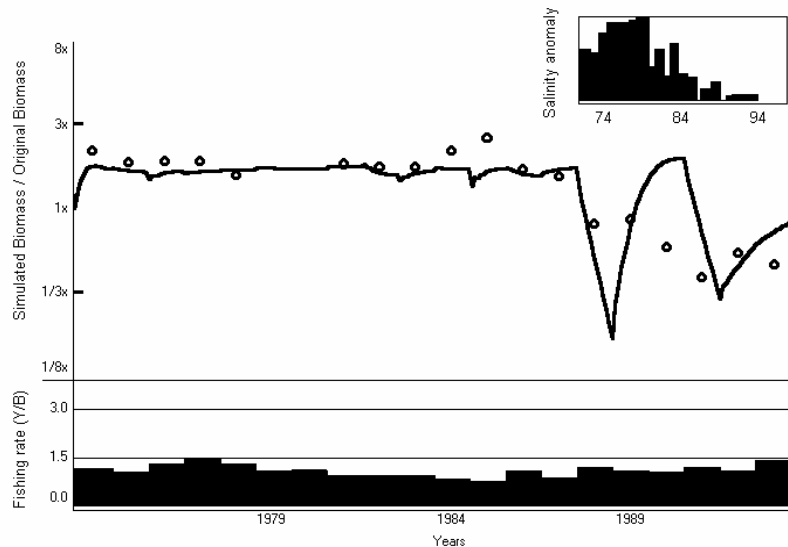

**Figure 2.** Ecosim simulated biomass (line) contrasted with independent estimates of biomass (dots) and real fishing pattern (black bars on the bottom) for the pink shrimp (*F. duorarum*) on the Campeche Sound, Mexico, for the period 1974 to 1993. Diagram on the top-right side shows the anomaly of salinity used as forcing factor.

and higher values represent bottom-up and top-down control, respectively.

Another aspect to be considered is the starting fishing rate,  $F$ , to be used for simulations. In this case two scenarios were tested, *selecting current  $F$ 's* as starting state, or *selecting random  $F$ 's* values. The difference is that during simulations fishing rate can follow a different routes to arrive at the optimization for a particular objective function.

**Closed loop simulation**

The performance of the simulations above can be improved by specifying some factors affecting the fishery. Here the incorporation of uncertainty for risk analysis, changes in catchability with time, the relative impact of the fishery and the comparison with some biological reference points were considered. All strategies were tested under this scope, and for particular situations, with emphasis on the shrimp stock.

**Results**

Strategy 1, as the base scenario, leaves things running under the current pattern, also representing the state of the ecosystem against which others strategies can be compared. Time series and a forcing factor (salinity anomaly) were incorporated as mentioned above.

<sup>1</sup> A. Navarrete del Proó and F. Arreguín-Sánchez. 2000. Depletion of the pink shrimp fishery on the Campeche Bank. INP-Campeche, CICIMAR-IPN. Mexico. 17p.

**Table 1.** Simulated average biomass (top) and its coefficient of variation (bottom) for commercial groups on the Campeche Sound, Southern Gulf of Mexico, for different harvesting strategies (S#). \$, J and E indicate optimization for economic, job and ecosystem criteria. Biomasses decreasing below 20% of starting biomass are between brackets. Bold numbers indicate higher values of biomass with respect to the starting value (For explanation see text).

	Average biomass													
	Her	Jac	Mac	Fla	Cat	Moj	Sna	Cro	Gro	Gru	Sha	O_f	Squ	Shr
S1 (=base)	6.18	1.84	1.08	0.91	0.70	0.85	0.11	0.46	0.47	0.23	0.09	0.53	0.11	1.41
S2 (=M\$)	3.18	1.69	0.36	<b>1.51</b>	(0.04)	(0.04)	<b>0.13</b>	(0.10)	<b>0.72</b>	(0.10)	<b>0.12</b>	0.22	0.04	<b>1.91</b>
S3 (=MJ)	5.65	(0.10)	(0.02)	<b>1.66</b>	(0.04)	(0.04)	<b>0.12</b>	(0.10)	<b>0.51</b>	(0.10)	(0.00)	0.40	<b>0.12</b>	<b>2.05</b>
S4 (=ME)	<b>6.57</b>	<b>1.84</b>	<b>1.17</b>	0.85	<b>0.80</b>	<b>0.93</b>	0.10	<b>0.48</b>	0.46	<b>0.24</b>	<b>0.09</b>	<b>0.54</b>	<b>0.12</b>	1.00
S5 (=M\$JE)	<b>6.47</b>	1.75	0.56	<b>1.20</b>	0.27	0.40	<b>0.11</b>	0.10	<b>0.48</b>	(0.05)	(0.00)	<b>0.56</b>	<b>0.14</b>	<b>1.74</b>
S6 (=M\$J)	(0.24)	(0.31)	(0.02)	<b>2.23</b>	(0.03)	(0.02)	<b>0.12</b>	(0.10)	<b>0.62</b>	(0.10)	(0.00)	0.19	0.07	<b>2.45</b>
S7 (=MJE)	5.70	(0.10)	(0.02)	<b>1.66</b>	(0.04)	(0.04)	0.08	(0.10)	<b>0.49</b>	(0.10)	(0.00)	0.30	0.08	0.90
S8 (=M\$E)	(0.25)	0.47	(0.03)	<b>2.18</b>	(0.03)	(0.02)	<b>0.12</b>	(0.10)	<b>0.64</b>	(0.10)	(0.00)	0.19	0.06	<b>2.35</b>
	Coefficient of variation													
	Her	Jac	Mac	Fla	Cat	Moj	Sna	Cro	Gro	Gru	Sha	O_f	Squ	Shr
S1 (=base)	16.92	8.63	17.61	2.62	15.37	16.05	24.05	23.40	15.29	23.14	22.43	9.00	13.68	29.22
S2 (=M\$)	18.37	6.94	38.20	<b>17.79</b>	(263.6)	(287.54)	<b>32.85</b>	(362.28)	<b>22.34</b>	(310.77)	<b>14.34</b>	37.51	51.13	<b>26.57</b>
S3 (=MJ)	5.65	(0.10)	(0.02)	<b>1.66</b>	(0.04)	(0.04)	<b>0.12</b>	(0.01)	<b>0.51</b>	(0.01)	(0.00)	0.40	<b>0.12</b>	<b>2.05</b>
S4 (=ME)	<b>2.50</b>	<b>2.46</b>	<b>1.80</b>	4.43	<b>4.17</b>	<b>2.28</b>	23.31	<b>11.93</b>	14.83	<b>14.84</b>	<b>5.42</b>	<b>3.95</b>	<b>6.10</b>	52.15
S5 (=M\$JE)	<b>5.12</b>	2.81	14.91	<b>9.26</b>	52.66	28.26	<b>25.73</b>	88.80	<b>14.45</b>	(93.26)	(319.72)	<b>7.63</b>	<b>12.30</b>	<b>25.06</b>
S6 (=M\$J)	(256.76)	(111.83)	(479.16)	<b>28.57</b>	(361.14)	(432.93)	<b>30.58</b>	(510.11)	<b>22.58</b>	(433.27)	(770.08)	40.10	51.91	<b>31.43</b>
S7 (=MJE)	12.10	(284.0)	(630.10)	<b>21.31</b>	(281.73)	(323.14)	20.16	(416.22)	<b>16.06</b>	(353.73)	(871.72)	11.50	14.29	68.97
S8 (=M\$E)	(249.05)	71.57	(439.75)	<b>28.17</b>	(356.98)	(426.51)	<b>30.24</b>	(503.85)	<b>23.01</b>	(428.12)	(701.42)	42.76	53.03	<b>32.23</b>

Her = Herrings, Jac = Jacks, Mac = Mackerels, Fla = Flatfish, Cat = Catfish, Moj = Mojarra, Sna = Snappers, Cro = Croakers, Gro = Groupers, Gru = Grunts, Sha = Sharks, O\_f = Other fish, Squ = Squids, and Shr = Shrimps.

Figure 2 shows simulations performed which, for the case of shrimp, exhibit an unstable behavior at the end of the period. This unstable behavior is a consequence of environmental effects plus the fishing stress imposed by the fishery. Ramírez-Rodríguez *et al.* (2000a, b) explain this in terms of the impact of the forcing factors on recruitment patterns and reproduction success. In terms of the model, simulations appears to fit independent data reasonably well.

### Comparing Strategies

Table 1 summarizes outputs of different strategies with respect to their impact on biomasses. In general terms the most important stocks, from the fishing point of view, shrimp, groupers and snappers were always positively impacted for all strategies, or at least not strongly affected in a negative sense. Except for Strategy 4 (optimizing ecological benefits), all strategies imply negative effects on at least one stock, taking as a criterion reduction of biomass below 20% of that of the base scenario. Strategy 5, optimizing three criteria simultaneously, represents the next best strategy in terms of biomass. Seven stocks increase in biomass while two decrease, but one of them disappears (sharks). Strategies

6, 7 and 8 (optimizing two criteria) show 4 stocks increased and seven decreased, with one of them disappearing (sharks).

As expected, biomasses decrease with trophic level for all strategies, at a rate of around 12% (Fig. 3a), corresponding roughly to the transfer efficiency suggested by Pauly and Christensen (1995); but also reflecting harvesting strategies. Coefficients of variation of biomass for the different strategies tend to increase with TL, with the exception of strategy 3 (maximize jobs), which decreases with trophic level. This behavior is likely due to the construction of the social index (Job/Catch), and suggests lower uncertainty in

**Table 2** Mean trophic level of the ecosystem computed for simulated harvesting strategies and changes in vulnerability (Vul) to predation. Low value between brackets; higher value in bold. \$, J and E represent economic, job and ecosystem stability criteria. S#'s represent strategies (for explanation see text)

Control Type	Vul = 0.2	Vul = 0.3	Vul = 0.4	Vul = 0.7
Strategies	(bottom-up)	(mixed)	(mixed)	(top-down)
S1 (=base)	-	2.330	-	-
S2 (=M\$)	(2.200)	2.282	2.345	2.446
S3 (=MJ)	2.204	2.274	2.309	<b>2.461</b>
S4 (=ME)	2.326	2.336	2.330	2.325
S5 (=M\$JE)	2.215	2.319	2.346	2.349
S6 (=M\$J)	-	2.228	-	-
S7 (=MJE)	-	2.268	-	-
S8 (=M\$E)	-	2.229	-	-

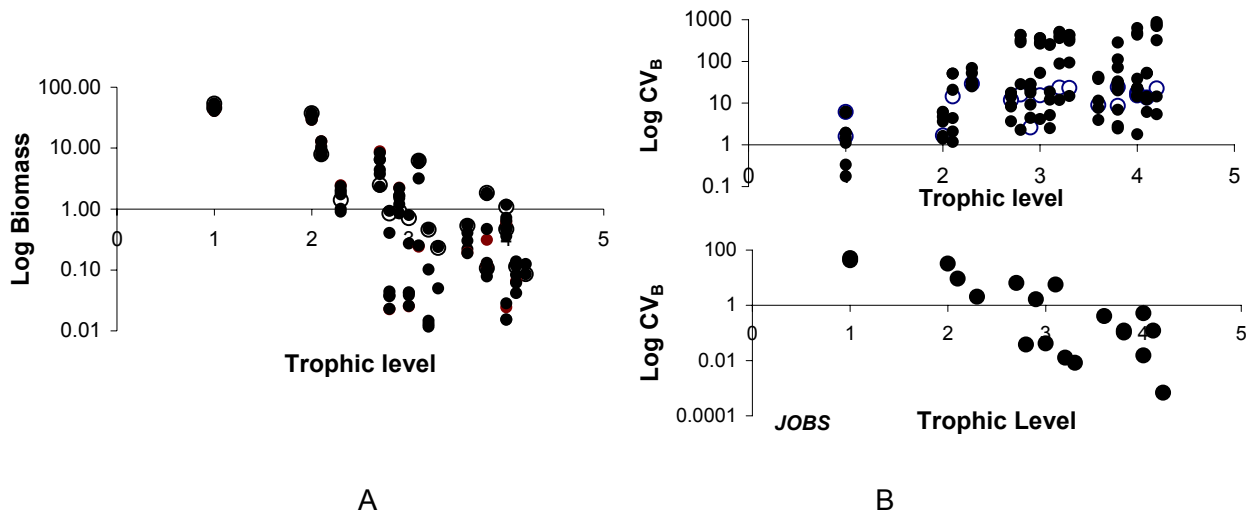

**Figure 3.** Changes in biomass (A) and the corresponding coefficient of variation (B) with trophic level for different harvesting strategies simulated with Ecosim. White dots are for strategy 1 (base scenario). Note the inverse relationship when jobs are optimized (for explanation see text).

employment if fisheries target high trophic levels (Fig. 3b).

With respect to the fleets, the ratio between the last year of simulation to the starting year was used to evaluate the relative effect of the harvest strategies. The only fleet which improves biomass under all strategies was the artisanal fishery targeting demersal fishes (art-DEM HL), which captures mostly high-priced species. The strategy which shows the best overall condition for all fleets was that which optimizes economic criteria (Strategy 2), but it is not a clear improvement on the base scenario.

Changes in vulnerability to predation suggest that mixed control involves less uncertainty in biomasses (expressed by the coefficient of variation) than 'bottom-up' or 'top-down' controls. For bottom-up control ( $V=0.2$ ), higher uncertainty was observed for intermediate trophic levels. For top-down control ( $V=0.7$ ), higher uncertainty was associated with higher trophic levels. However, a relatively constant, low uncertainty was observed for mixed control (Fig. 4). These aspects should be given further investigation because ecosystem mechanisms behind the observed behaviour could explain what happens in those cases where top predators have been removed from the ecosystem.

Mean trophic level of the ecosystem (MTLE) was computed for a different combination of strategies and vulnerabilities (Table 2). Strategies, which optimize economic yield and jobs show a proportional increase of MTLE with vulnerability. A strategy optimizing the three criteria shows a decrease in MTLE with low vulnerability ( $v = 0.2$ ) corresponding to 'bottom-up control', but no

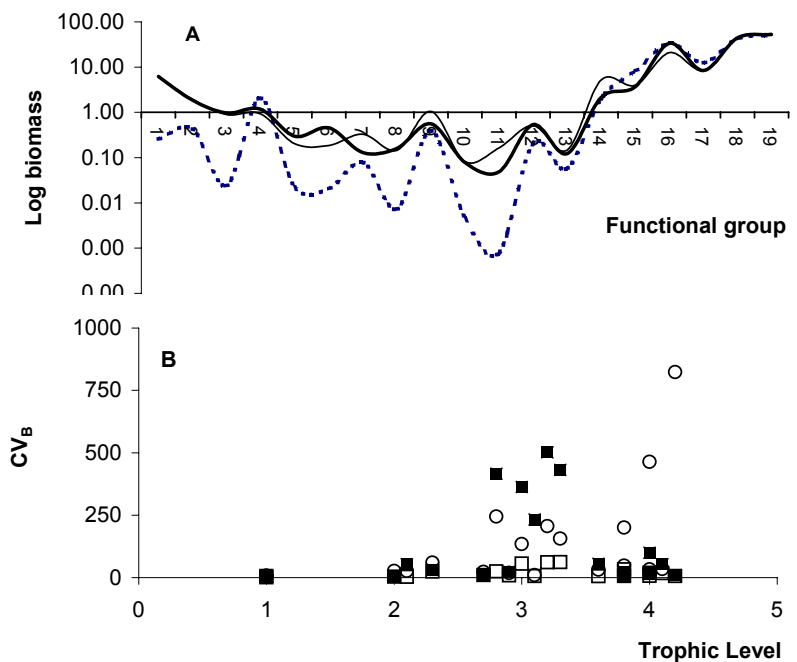

**Figure 4.** Effect of changes in vulnerability in Strategy 2 (optimizing the economic criterion). A) on group biomasses, and B) on uncertainty of biomass by trophic level. Low values for vulnerability,  $v=0.2$  (dashed line and black squares) indicate bottom-up control; high values,  $v=0.7$  (thin line and white circles) top-down and intermediate values mixed control,  $v=0.4$  (bold line and white squares).

**Table 3.** Conditions established for harvesting scenarios during close loop simulations.

	CV	RIF	max Δq	wfS
<i>Strategy 4, optimizing economic rent, jobs and ecosystem stability</i>				
Scenario 1	0.2 all (groups)	1 all	0.1 all	1
Scenario 2	0.2 all	3 Shrimp, 1 others	0.2 Shrimp, 0.05 others	1
Scenario 3	0.2 all	1 all	0.1 all	5
Scenario 4	0.2 all	3 Shrimp, 1 others	0.2 Shrimp, 0.05 others	5
Scenario 10	0.4 Shrimp, 0.2 all	3 Shrimp, 1 others	0.2 Shrimp, 0.05 others	1
Scenario 11	0.4 Shrimp, 0.2 all	3 Shrimp, 1 others	0.2 Shrimp, 0.05 others	5
<i>Strategy 3, optimizing ecosystem stability</i>				
Scenario 5	0.2 all	1 all	0.1 all	1
Scenario 6	0.2 all	3 Shrimp, 1 others	0.2 Shrimp, 0.05 others	1
Scenario 7	0.2 all	1 all	0.1 all	5
Scenario 8	0.2 all	3 Shrimp, 1 others	0.2 Shrimp, 0.05 others	5
Scenario 9	0.4 Shrimp, 0.2 all	3 Shrimp, 1 others	0.2 Shrimp, 0.05 others	5

CV = coefficient of variation, RIF = relative impact of the fishery, max Δq = maximum rate of catchability increase. WfS = ecological weighting factor assigned to Shrimp group at the beginning of simulations.

change was produced for mixed and ‘top-down control’ ( $v \geq 0.3$ ). Strategy 4, optimizing ecosystem stability, did not change with vulnerability (Fig. 5).

*Starting simulations with current F’s vs. Random F’s*

The reason for this test was to observe the effect of running a given strategy by using a predefined F (i.e. current fishing mortality) to initiate simulations. The use of random values of F will generate a number of iterations, which could change the way in which a simulation approaches the solution of the objective function. In all the cases, the results at the end of the simulation were the same. Further work on simulations will initiated by using random F.

*Closed loop simulations*

For this analysis, uncertainty was incorporated through the coefficient of variation associated with each group. The fleet impact on the ecosystem was also provided by a weighting factor, in this case I assumed that the artisanal fleet do not cause an impact (factor = 1X), while the shrimp fleet factor was 3X. Changes in catchability with time were also considered in different ways. The upper and lower bounds in biomass of the groups were used as biological reference points to evaluate the state of the stock. Conditions for simulations are defined in Table 3.

For all the strategies, the shrimp stock becomes unstable in the last years of simula-

tion, but this behaviour is associated with forcing factors as mentioned previously. For the two scenarios related to Strategy 5, croakers and grunts fall below the level of 0.5B at the end of the simulated period; while sharks fall below this level, disappearing before year 10 of the simulation (Figure 6). For Strategy 4, and with the exception of shrimp, there no stocks declined below the reference point of 0.5B (Fig. 7).

*Performance index*

The weighted total objective performance was computed for each scenario mentioned above, and same selected outputs are shown in Table 4.

**Discussion**

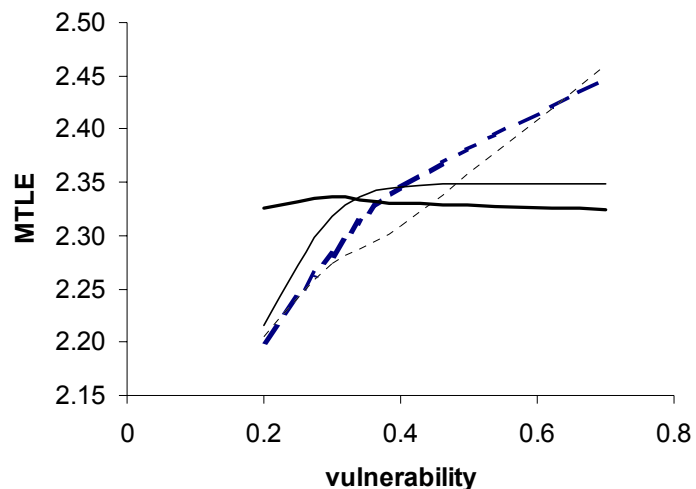

**Figure 5** Changes in the mean trophic level for the ecosystem (MTLE) as a function of vulnerability. Strategy maximizing ecosystem stability is not affected (bold line); Strategies maximizing economic rent and jobs increase in proportion to vulnerability (dashed and dotted lines, respectively). Strategy optimizing the three criteria (thin line) increases for transition between bottom-up to mixed control, and remains stable from mixed to top-down control.

Currently, Ecopath with Ecosim constitutes a useful tool to explore harvesting strategies. The incorporation of independent estimations of biomass and fishing patterns provides an important possibility for its use for exploring management strategies. Moreover, the application of objective functions to optimize single or multiple criteria, the impact of fleets, changes in catchability with time as well as uncertainty, give a good opportunity to consider an ecosystem framework for management purposes.

Simulated strategies give a number of scenarios concerning changes in ecosystem pools, which change in different ways. Strategy 4 (optimizing ecosystem stability) was the only option which did not provoke decline in the biomass of any group; moreover, biomass increased in most of them. Moreover, the most important resources, shrimp, groupers and snappers were reduced under any strategy tested. However, groups like grunts, croakers, mojarra, catfish and sharks were reduced under most strategies, as measured by a decline in biomass below 20% of base scenario (Strategy 1). Sharks disappeared in most cases. It was also noticed that when a simulation optimized only two criteria, several groups were reduced, but with high uncertainty, as expressed by the coefficient of variation (Table 1).

Decrease of biomass with trophic level (Fig. 3a) for all strategies appears to be associated with transfer efficiencies. However, those data also reflect fishing stress imposed by exploitation, suggesting that the rate of change could be lower for unexploited systems. This could be an impact on biodiversity. In this sense, more investigation is required.

Vulnerability to predation, related to the type of biomass-flows control, suggests that, for mixed

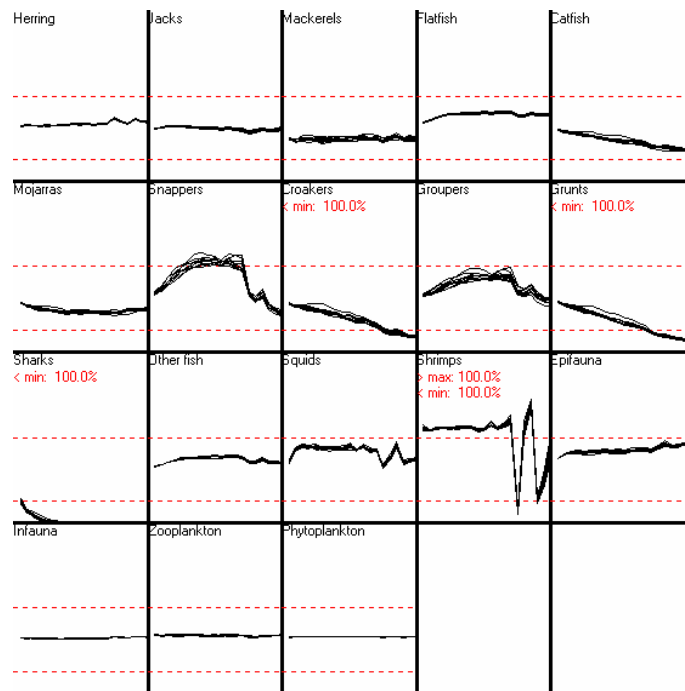

**Figure 6.** Simulated biomasses from close loop simulation for Strategy 4 (optimizing economic, jobs and ecosystem criteria) under the following conditions: a) assigning a factor of 1 to ecosystem criteria as well as for the shrimp group. b) Assigning uncertainty to biomass for each group as CV = 20%. c) Shrimp fleet impact ecosystem three times respect to the artisanal fleets. d) Catchability for artisanal fleets increases 5% each year while for shrimp fleet 20%. e) Reference biological level of biomass (dashed lines) fixed at 0.5B and 2.0B. Note that Croakers, Grunts and Sharks fall below critical level of 0.5B, and Shrimps maintain large uncertainty during the last period because the effect of forcing factors.

control, uncertainty decreases, while the opposite applies to top-down or bottom-up control. This uncertainty also suggests that a more stable system might obtain under mixed control.

This is a research line to be explored, because it could be associated with removal large predators in an ecosystem, such as has occurred in some collapsed fisheries.

**Table 4.** Weighted total performance indices for simulation of harvesting strategies.

Criteria	Strategy 5 max (\$JE) Scenario 4		Strategy 4 max (ME) Scenario 9		Strategy 5 max (\$JE) Scenario 11	
	Open Loop	Closed Loop	Open Loop	Closed Loop	Open Loop	Closed Loop
	<i>Relative index (Close Loop / Open Loop)</i>					
Net Economic Value	3012.81	2486.52	420.17	1733.4	3012.95	2531.03
Social value (employ.)	2887.83	2047.38	1645.64	1586.6	2887.84	2069.5
Ecosystem stability	-44.46	-43.61	-23.1	-21.06	-44.46	-43.97
Overall value	0.66	0.4	-0.23	-0.21	0.66	0.41
Net Economic Value	0.825		4.125		0.840	
Social (employ.) value	0.709		0.964		0.717	
Ecosystem stability	0.981		0.912		0.989	
Overall value	0.606		0.913		0.621	
Figure	6		7			

Ar present, the problem of the pink shrimp (*F. duorarum*) fishery in Campeche Sound is a great challenge for scientists, managers and fishers in Mexico. The main question here is, what can we do to rebuild this fishery?

Initially the role of the forcing factors is extremely important creat-



ing both low stock abundance and uncertain biomass and fishery behavior (Figure 2) at the end of the period. During The simulations measured social impact as the Job/Catch ratio. In the shrimp fishery, employment is now around 10% of that in the mid-1970's, while yields have collapsed. Evidently, some fishers have continued fishing despite low yields, a change that can modify the Job/Catch ratio. Some looked for alternative fishing jobs, adding fishing pressure to alternative fish resources. Some other fishers migrated to other sectors. These social dynamics are not captured by the fixed values in the simulation model.

In general terms, best option from the simulations is Strategy 4 (Fig. 7), which optimizes the ecosystem stability criteria. Other options tested, such as optimizing economic, social and ecological criteria simultaneously, yield some undesirable scenarios, since some stocks decline and sharks tend to disappear.

### Acknowledgments

I would like to acknowledge to Dr. Kevern Cochran from FAO for his invitation to participate in the FAO / UBC Fisheries Centre workshop on "The use of ecosystem models to investigate multispecies management strategies for capture fisheries". Thanks also to the Japan Government who financed me for this activity, and to the National Polytechnic Institute, Mexico, for partial support through CEPEPI-980056 project, COFAA and EDI.

### References

- Arreguín-Sánchez, F. 2000. Octopus-red grouper interaction in the exploited ecosystem of the northern continental shelf of Yucatan, Mexico. *Ecological Modelling* (in press).
- Christensen, V. and D. Pauly. 1992. Ecopath II - a software for balancing steady - state ecosystem models and calculating network characteristics. *Ecological Modelling* 61: 169-185
- Hilborn, R. and C. J. Walters. 1992. *Quantitative fisheries stock assessment*. Chapman and Hall. New York, 570pp.
- Manikchand-Haileman, S., L.A. Soto and E. Escobar. 1998. A preliminary trophic model of the continental shelf, South-western Gulf of Mexico. *Estuarine, coastal and shelf Science*. 46: 885-899
- Pauly, D. and V. Christensen. 1995. Primary production required to sustain global fisheries. *Nature* 373: 255-257
- Ramírez-Rodríguez, F. Arreguín-Sánchez and D. Lluch-Belda. 2000a. Collapse of the pink shrimp *Farfantepenaeus duorarum*(Burkenroad, 1939) fishery and sea surface temperature in Southern Gulf of Mexico. (submitted to *Fish. Bull.*)

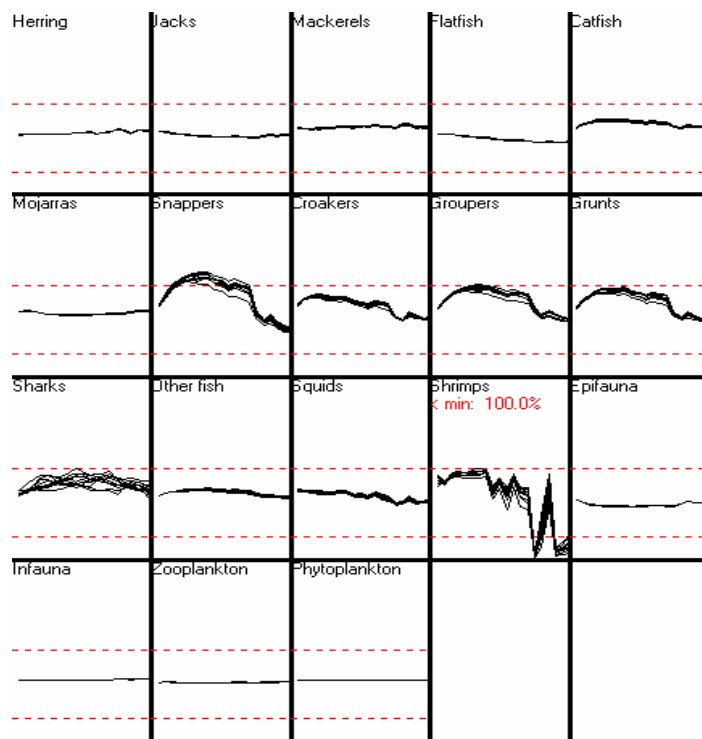

**Figure. 7** Simulated biomasses from close loop simulation for Strategy 3 (optimizing ecosystem criteria) under the following conditions: a) assigning a factor of 5 to ecosystem criteria as well as for the shrimp group. b) Assigning uncertainty to biomass for each group as CV = 20%, except for shrimp with CV = 40%. c) Shrimp fleet impact ecosystem three times respect to the artisanal fleets. d) Catchability for artisanal fleets increases 5% each year while for shrimp fleet 20%. e) Reference biological level of biomass (dashed lines) fixed at 0.5B and 2.0B. Note that Croakers, Grunts and Sharks remains at "health" levels of biomass (>0.5B), and Shrimps maintain uncertainty during the last period because the effect of forcing factors.

- Ramírez-Rodríguez, M. E.A. Chávez and F. Arreguín-Sánchez. 2000b. Perspective of the pink shrimp (*Farfantepenaeus duorarum* Burkenroad) fishery of the Campeche Bank, Mexico. *Ciencias Marinas*, 26(1):97-112
- Schaefer, M. B. 1957. A study on the dynamics of the fishery for yellowfin tuna in the eastern tropical Pacific Ocean. *Inter-Am. Trop. Tuna Comm. Bull.* 2:247-285
- SEMARNAP. 1998. *Anuario estadístico de pesca 1997*. Secretaría de Medio Ambiente, Recursos Naturales y Pesca. México. 241pp.
- Walters, C., V. Christensen and D. Pauly. 1997. Structuring dynamic models of exploited ecosystems from trophic mass-balance assessments. *Reviews in Fish Biology and Fisheries*. 7: 1-34

## Evaluating harvesting strategies for fisheries in the Central Gulf of California ecosystem

Francisco Arreguín-Sánchez<sup>1</sup> and Luis E. Calderón-Aguilera<sup>2</sup>

<sup>1</sup>CICIMAR, La Paz, Mexico

<sup>2</sup>CICESE, Ensenada, Mexico

### Abstract

Harvesting strategies were tested for fisheries of the west-central region of the Gulf of California. Simulations using Ecosim were based on a previously constructed Ecopath model emphasizing the benthic community and accounting for trawled shrimp and its by-catch, sardine and multispecies small-scale fisheries. In order to calibrate simulated biomasses, time series of catch-per-unit-effort and exploitation patterns for the shrimp and sardine fisheries were incorporated. Simulated harvesting scenarios consider economic value, social value (employment), ecosystem stability attributes, and all of these values combined, as criteria for optimization. Uncertainty per group, catchability changes with time and relative impact per fleet were also considered. Two weighting factors were compared for the ecosystem stability criterion; the conservation of marine mammals and sea birds, and the B/P ratio per group. Simulations emphasizing conservation indicate that maximization of ecosystem stability is the only reasonable strategy, because other criteria imply depletion of some stocks, and even cause some of them disappear. Outputs based on the B/P ratio resulted in only one non-desirable outcome (when the employment criterion was maximised). Here some stocks were depleted or disappeared, while other criteria offered reasonable alternatives. The overall performance index resulted in the same value for both scenarios, but individual criteria suggest that scenarios based on the B/P ratio offer better possibilities

### Introduction

The central Gulf of California (GoC) is a heavily exploited marine ecosystem. Native people have fished the abundant resources of this productive area since pre-Spanish times (Edwards 1978). The GoC is divided into four different regions according to topography and physical processes: the mouth, the southern (also called central) GoC, the northern GoC, and the upper GoC (Lavín *et al.* 1997). This contribution is aimed at the exploration of management strategies of fisheries in the central GoC within an ecosystem approach based on the Ecopath with Ecosim software (Christensen *et al.* 2000), which incorporates formal optimization routines.

### Methods

#### Model description

This ecosystem analysis emphasizes benthic communities where shrimp trawl and other important fisheries operate, such as those targeting Monterrey sardine (*Sardinops caerulea*) and giant squid (*Dosidiscus gigas*). Data on biomass for the benthic components of the ecosystem comes from Pérez-Mellado and Findley (1985), who collected catch and by-catch data from 290 hauls made between Sept. 1978 and March 1979.

An Ecopath mass-balance model for the central GoC ecosystem was constructed by Arreguín-Sánchez *et al.* (2000). It consists of 27 functional groups which were selected on criteria such as species abundance, by-catch structure, and the economic importance of the species. One group covers marine mammals, one represents aquatic birds, one for sharks and rays, and 11 for fish. For invertebrates, 2 groups are mollusks, 5 are macrocrustaceans, 2 are small invertebrates, and one is zooplankton. Phytoplankton and detritus represent primary producers. By-catch is explicitly identified as a non-living group named 'discarded fish' (Figure 1). We assumed that by-caught fish die on board, while most macrocrustaceans and mollusks remain alive. Practically all by-catch is returned to the sea after shrimp have been sorted from trawl hauls.

The fisheries in the ecosystem were grouped in three fleets. The first is a trawling shrimp fleet, mainly exploiting penaeid shrimp as target species. The shrimp fishery, the most profitable in the GoC, targets two species, brown shrimp *Farfantepenaeus californiensis* (Holmes 1900) and blue shrimp *Litopenaeus stylirostris* (Stimpson 1871). The latter comprise over 80 % of total shrimp catch (Snyder-Conn and Brusca. 1975; Mathews 1981), although in some years there are sharp changes in catch composition (Calderon-Aguilera and Burgueño-Aburto, 1993; Calderon-Aguilera and Campoy-Favela, 1993).

Two other fishing fleets were considered in the model. A small pelagics fleet, mainly fishing the Monterrey sardine, and a small-scale fleet. The latter has a number of target species, of which the giant squid is the most important, along with several species of Serranids and Lutjanids (Table 1).

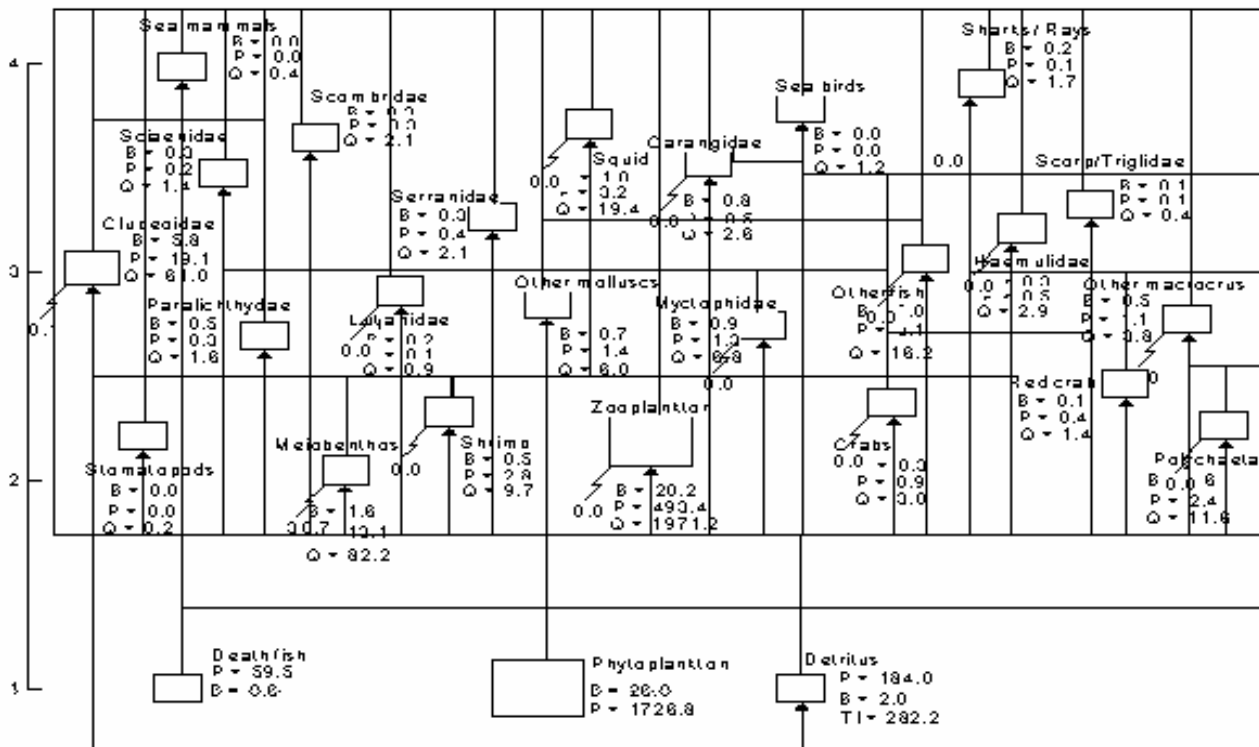

**Figure. 1** Flows of biomass diagram for the ecosystem of the west-central coast of the Gulf of California, Mexico. Biomass (B), Consumption (Q) and fishery harvest are in g m<sup>-2</sup> wet weight; all flows and production are in g m<sup>-2</sup> year<sup>-1</sup> (from Arreguín-Sánchez *et al.*, 2000, unpublished).

### Testing harvesting strategies

Five harvesting strategies were tested using EcoSim (e.g. Pauly, 1998) aimed at different objectives. In the first strategy, optimization was done without any selection of criteria, but based on the historical trend. The other four strategies optimize some criteria such as: the economic value, ecosystem stability, social value (measured as employment) and, the fifth scenario, the previous three objectives combined.

In addition, three different vulnerabilities to predation were tried:  $v=0.4$  representing mixed control (set as default for optimization). ‘Bottom-up’ and ‘top-down’ control were represented with values  $v=0.2$  and  $v=0.7$ , respectively.

For the simulations, the social criterion was defined per fleet as follows; small-scale catches do not generate important profits but provide jobs at a rate of 10 jobs/catch value. Comparatively, the shrimp fishery was set at 0.5 jobs/catch value and the sardine fishery at 0.1 jobs/catch value.

For ecosystem stability, the weighted value of marine mammals and birds was set to 1 while the rest of the groups got 0. This was to emphasize the importance of conservation for mammals and birds, but allowing the captures of others. In the second case, the importance of all groups was

weighted by B/P.

For all strategies, the mean trophic level of the ecosystem, MTLE, was computed based on simulated biomasses. The index was constructed as:

$$MTLE = \left( \sum_{i=1}^n B_i TL_i \right) / \sum_{i=1}^n B_i$$

**Table. 1** Commercial catch (g m<sup>-2</sup>) per fleet of groups considered in the model. Trophic level =TL.

Group \ catch	TL	Small Scale	Shrimp Trawl	Sardine	Total catch
Sea mammals	4.0				0
Sea birds	3.9				0
Sciaenidae	3.5	0.032	0.025		0.06
Scombridae	3.7	0.092	0.001		0.09
Sharks / Rays	3.9	0.061	0		0.06
Squid	3.7	0.367			0.37
Carangidae	3.5	0.001	0.001		0
Serranidae	3.4	0.18	0.18		0.36
Scorp/Triglidae	3.3		0.062		0.06
Other fish	3.2	0.054	0.054		0.11
Haemulidae	3.2	0.001	0.196		0.2
Clupaeidae	3.0		0.005	14.5	14.51
Lutjanidae	2.9	0.008	0		0.01
Paralichthyidae	2.7	0.126	0.126		0.25
Myctophidae	2.7		0		0
Shrimp	2.3		1.432		1.43
Crabs	2.4	0.203			0.2
Total catch		1.125	2.081	14.5	17.706
Trophic level		3.28	2.6	3.02	2.99

where  $B$  = biomass,  $TL$  = the mean trophic level,  $i$  = stock/group index.

Two forms of optimization were conducted; an 'open loop' situation where criteria were optimized following a nonlinear optimization procedure known as the Davidson-Fletcher-Powell (DFP) method (see Christensen *et al.* 2000). The second level, named 'closed loop', where, under the open loop framework, catchability changes and uncertainty in group biomass were also considered.

## Results

Independent time series of biomass and exploitation pattern for the period of 1965 to 1997 were used to compare observed versus Ecosim-simulated biomasses for shrimp (Figure 2) and sardine (Figure 3) fisheries. In both cases fitting results appear to be a reasonable representation by Ecosim.

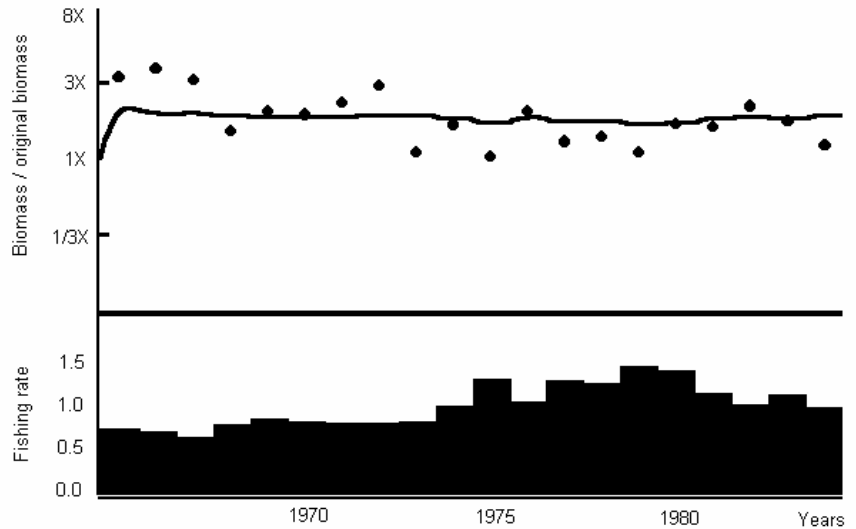

**Figure. 2** Ecosim simulated biomass (wavy line) contrasted with independent estimates of catch-per-unit-effort (dots) and fishing pattern (black bars at bottom) for the brown shrimp (*F. californiensis*) of the Gulf of California, Mexico, for the period 1965 to 1984.

Outputs for the open loop simulations are shown in Table 2 in terms of biomass per group for different harvesting strategies and vulnerabilities to predation. For the current situation (expressed by mixed control,  $v=0.4$  in Table 2), strategies that resulted in higher biomasses for most groups were those that maximize ecosystem and social criteria.

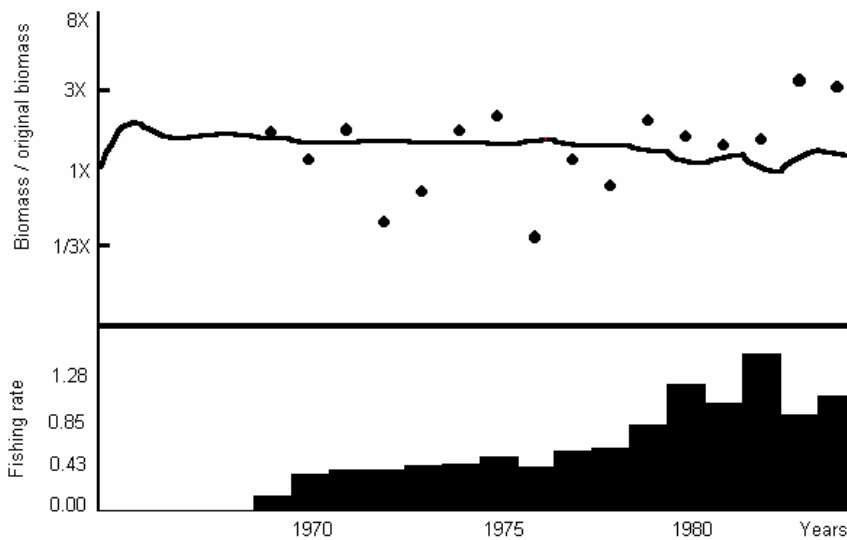

**Figure. 3** Ecosim simulated biomass (wavy line) contrasted with independent estimates of catch-per-unit-effort (dots) and fishing pattern (black bars at bottom) for the Monterrey sardine (*S. caeruleus*) in the Gulf of California, Mexico, for the period 1969 to 1984.

Under bottom-up and top-down control, the scenario represented by optimization of employment was the one where most groups increase in biomass.

Such optimizations include exploited species as well as conservation of sea mammals and sea birds. Commercially important groups, such as shrimp, lutjanids and clupeoids reached their maximum biomasses under different criteria depending on the strategy, however most of their biomasses were maximized under 'top-down' control. The scenario that maximized total ecosystem biomass was when optimizing employment criterion under 'top-down' control.

**Table 2.** Gulf of California: estimated biomasses per group (g m<sup>-2</sup>) for different harvesting strategies and vulnerabilities to predation. Bold numbers/light shading indicate highest values between criteria for each type of flow control (=vulnerability). AC=all objectives combined.

Biomass Group	Mixed control (v=0.4)			'Bottom-up' control (v=0.2)			'Top-down' control (v=0.7)					
	Economic	Ecosystem	Social	AC	Economic	Ecosystem	Social	AC	Economic	Ecosystem	Social	AC
Sea mammals	0.013	0.022	<b>0.023</b>	0.022	0.013	0.019	<b>0.055</b>	0.019	0.010	0.012	<b>0.191</b>	0.033
Sea birds	0.012	0.019	0.016	<b>0.018</b>	0.011	0.016	<b>0.047</b>	0.016	0.009	0.012	<b>0.140</b>	0.026
Sciaenidae	0.122	0.396	<b>1.529</b>	0.435	0.289	0.384	0.011	<b>0.438</b>	0.041	0.162	<b>3.011</b>	0.237
Scombridae	0.198	0.336	<b>0.560</b>	0.350	0.263	0.351	0.002	<b>0.364</b>	0.063	<b>0.257</b>	0.008	0.192
Sharks / Rays	0.232	<b>0.236</b>	0.041	0.217	0.140	<b>0.214</b>	0.001	0.162	0.316	0.206	0.003	<b>0.364</b>
Squid	1.124	1.585	1.513	<b>1.607</b>	0.943	<b>1.419</b>	0.019	1.396	0.880	1.064	1.971	<b>2.033</b>
Carangidae	0.975	1.006	<b>1.409</b>	1.097	0.840	1.032	<b>2.901</b>	1.041	2.108	0.941	<b>2.537</b>	1.064
Serranidae	<b>0.492</b>	0.352	0.306	0.404	0.262	<b>0.351</b>	0.002	0.273	<b>0.647</b>	0.370	0.004	0.552
Scorp/Trigl.	0.127	0.129	<b>0.347</b>	0.169	0.097	0.127	0.097	<b>0.130</b>	0.101	0.095	<b>0.244</b>	0.067
Other fish	1.846	<b>2.538</b>	2.045	2.334	2.099	2.470	<b>4.685</b>	2.525	1.132	2.220	<b>4.219</b>	1.846
Haemulidae	0.318	0.402	<b>0.558</b>	0.425	0.316	0.370	0.365	<b>0.377</b>	0.172	0.325	<b>0.801</b>	0.390
Clupaeidae	9.575	<b>12.952</b>	12.946	12.894	9.283	11.786	<b>31.237</b>	11.827	5.026	9.957	<b>36.733</b>	14.028
Lutjanidae	0.119	<b>0.170</b>	0.070	0.130	0.185	0.185	0.011	<b>0.192</b>	0.043	<b>0.156</b>	0.021	0.042
Paralichthyidae	<b>0.880</b>	0.598	0.705	0.737	0.442	<b>0.571</b>	0.005	0.458	1.314	0.611	0.014	<b>1.372</b>
Other molluscs	0.551	0.672	<b>0.957</b>	0.696	0.726	0.670	<b>0.977</b>	0.708	0.456	0.819	<b>5.000</b>	1.229
Mycetophidae	<b>1.123</b>	0.839	0.381	0.787	0.883	0.847	<b>1.136</b>	0.848	<b>2.724</b>	1.244	0.143	0.108
O. macrocrust.	0.415	<b>0.426</b>	0.332	0.370	0.516	0.476	<b>0.756</b>	0.497	0.081	<b>0.433</b>	0.276	0.044
Red crab	0.040	0.051	<b>0.084</b>	0.053	0.061	0.058	<b>0.080</b>	0.061	0.006	0.041	<b>0.319</b>	0.017
Shrimp	0.583	<b>0.860</b>	0.790	0.845	0.467	0.651	0.562	<b>0.655</b>	0.882	0.535	<b>1.119</b>	1.444
Crabs	0.262	<b>0.324</b>	0.291	0.295	<b>0.366</b>	0.347	0.002	0.354	0.038	<b>0.282</b>	0.005	0.066
Polychaeta	0.524	0.584	<b>0.636</b>	0.572	0.635	0.607	<b>0.736</b>	0.623	0.263	0.661	<b>1.252</b>	0.438
Stomatopods	0.010	<b>0.014</b>	0.003	0.008	0.021	0.018	<b>0.030</b>	0.019	0.002	0.020	<b>0.009</b>	0.004
Meiobenthos	<b>20.451</b>	19.595	19.635	19.613	<b>20.579</b>	19.880	19.022	19.866	<b>21.295</b>	20.284	14.600	19.408
Zooplankton	<b>1.696</b>	1.409	1.451	1.465	1.638	1.607	<b>1.745</b>	1.597	<b>1.940</b>	1.586	1.189	0.720
Phytoplankton	25.797	26.889	26.871	<b>26.877</b>	25.870	26.338	<b>26.885</b>	26.345	24.182	25.911	<b>38.377</b>	27.607
Discarded fish	19.929	19.915	<b>0.621</b>	18.491	19.584	19.797	<b>22.980</b>	19.305	21.219	19.521	17.582	<b>21.958</b>
Detritus	16.992	<b>17.693</b>	17.637	17.647	17.041	17.289	<b>17.514</b>	17.293	16.116	17.100	<b>22.334</b>	18.750

**Table 3.** Summary of Mean Trophic Level for the Ecosystem under different harvesting strategies and vulnerabilities.

Strategy (Maximizing criteria)	Vulnerability		
	0.2	0.4	0.7
Economic value (\$)	1.67	1.68	1.65
Ecosystem stability (E)	1.68	1.69	1.67
Social Value (J)	1.82	1.85	1.88
'Big compromise' (\$EJ)	1.68	1.72	1.67

In general terms, higher values of MTLE were reached under the social criterion. Within this, the highest value was obtained when vulnerability to predation corresponded to a system under top-down flow control (Table 3). This is mainly because this scenario resulted in the highest biomass for most groups with respect other scenarios in Table 2. It is also interesting that this scenario (social optimization with top-down control) provides the larger number of jobs per catch, and fish species of higher trophic level (Table 1).

*Closed-loop simulation*

For this analysis, uncertainty was incorporated into simulated scenarios through the coefficient of variation (CV) of the biomass for each group (in the absence of specific data, we assumed a CV=20% for all groups). We assumed that fleets affected the ecosystem differently. The shrimp trawl fishery had a major impact, so we used a factor of 3X; the sardine fishery had a lower factor (2X); and we assumed a null impact (1X). for the small-scale fleet. Catchability was assumed to increase at a rate of 5%, 10% and 15% per year for small-scale, shrimp and sardine fleets. Upper and lower bounds of biomass of the groups were used as biological reference points to evaluate the state of the stocks during simulations.

The main overall evaluation for the scenario

**Table. 4** Closed loop simulation emphasizing mammals and aquatic birds.

Criteria	Open loop simulation w/o assessment	Means achieved through closed loop simulation	% enhanced performance w/ perfect information
Net economic value	381.59	267.11	30
Social (employment) value	671.22	428.21	36
Ecosystem stability	-0.27	-0.7	59
Overall performance	2.18	1.44	34

**Table. 5** Closed loop simulation weighting all biomass groups by the B/P ratio.

Criteria	Open loop simulation w/o assessment	Means achieved through closed loop simulation	% enhanced performance w/ perfect information
Net economic value	427.84	294.69	31
Social (employment) value	605.89	386.57	36
Ecosystem stability	-22.51	-20.7	8
Overall performance	2.14	1.41	34

where conservation of mammals and birds was emphasized is shown in Tables 4. Compared with the open loop simulation, net economic value was enhanced by 30%, 36% for social value and overall performance increased by 34%. However, ecosystem stability decreased 59% (Table 4). The reason for this is probably because the biomass of some groups was depleted below 50% of the original biomass, here assumed as a critical threshold for the stocks. (Figure 4).

When the reciprocal of P/B per group was used as the weighting factor as a conservation criterion, the economic and social values, and the overall performance index, were similar, but ecosystem stability was greatly improved (Table 5).

**Discussion**

Even when we accept the fitting of biomasses in Ecosim (*comparing observed versus simulated biomasses*) as a reasonable procedure, the figures suggest some deviations in both clupeids and shrimp. For clupeids it is well known that inter-annual stock variation is strongly associated with forcing factors (Nevárez-Martínez, 2000). Regarding the shrimp group, the fit appears to be better than clupeids, but we also noticed that the residuals suggest the influence of forcing factors (see also López-Martínez, 2000). Environmental data were not incorporated in the present case, but they must be further considered.

Another aspect regarding the time series is that we used catch-per-unit-effort as an index of stock abundance for both clupeids and shrimp, but we have no good evidence that this relationship applies. For simulations, vulnerability to predation shows a strong influence on biomasses. It suggests that further consideration must be taken during calibration in order to improve the fit. This is because we can expect changes in vulnerability due to variation in biomass of the groups.

During the closed loop simulation, two scenarios were tested, as defined above, using weighting factors for conservation of marine mammals and sea-birds and the use of the reciprocal of P/B for all groups. Simulations were conducted to explore maximization of three criteria, economic, social and ecosystem stability, as well as the combination of them. In the first scenario, some groups disappear before the conclusion of the

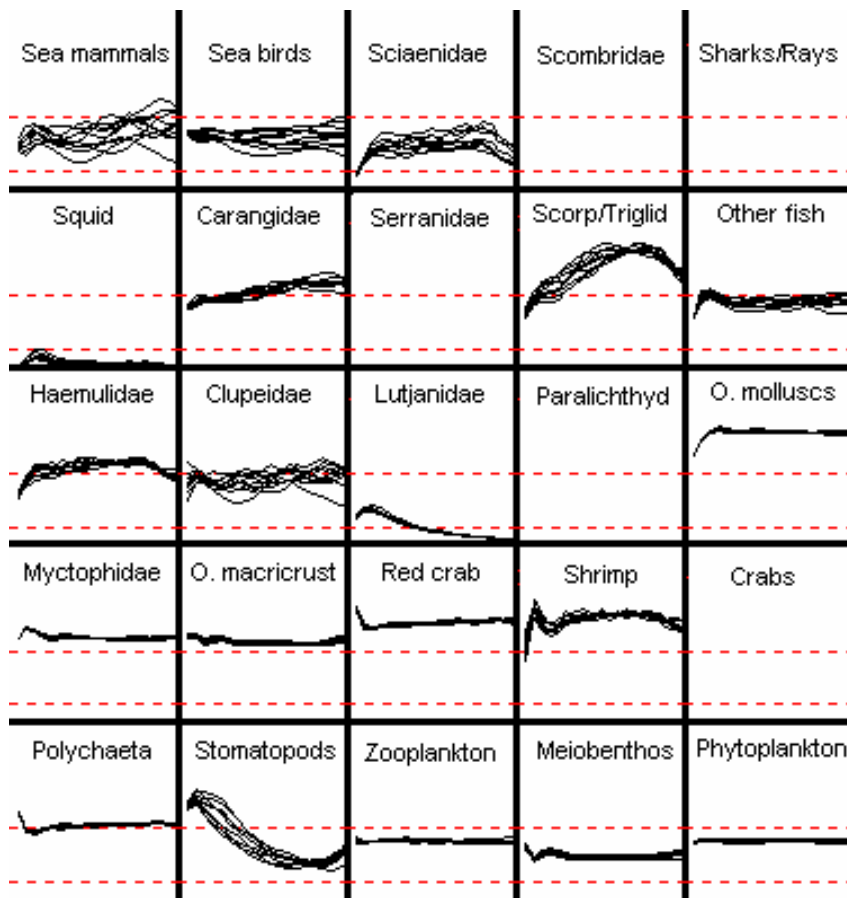

**Figure 4** Simulated biomasses from close loop simulation for Strategy 4, optimizing economic, jobs and ecosystem criteria combined, assigning a factor of 1 to marine mammals and sea birds to emphasize ecosystem criteria (other pools set 0). Simulations were running considering a) uncertainty on biomass per group as  $CV = 20\%$ . b) Relative impact of fleets using factor of 3, 2 and 1 for shrimp, sardine and small-scale, respectively. c) Catchability increases a maximum of 5%, 10% and 15% for small-scale, shrimp and sardine fleets. e) Reference biological level of biomass (dashed lines) are fixed at  $0.5B$  and  $2.0B$ .

simulated period. The same happens when the three criteria are combined. Maximization of the social criterion resulted in some groups falling below  $0.5$  of the original biomass.

When the reciprocal of the  $P/B$  ratio was used as a weighting factor, aimed at maintaining the stability of the ecosystem, some stocks disappear when the social criterion was maximised. The reason for this is probably because optimization of employment implies a large number of fishers working on the fishable stock.

The MTLE changes according to policy criterion and vulnerability to predation. In the first case criteria are associated to harvesting strategies, and significant changes should be demonstrated in further work as an index of the impact of fishing on the ecosystem structure. Regarding vulnerability, we cannot manage, in practice, how

ecosystems control flows of biomass. However, vulnerability to predation influences ecosystem function and it could have some effect on predictions.

The overall performance increased 34% through the closed loop simulation, regardless of the weighting value given to the biomass groups. However, ecosystem stability greatly improved when they were weighted by the reciprocal of the  $P/B$  (Figure 5).

### Acknowledgments

The first author acknowledges Dr Kevern Cochrane from FAO for his invitation to participate in the FAO/UBC Fisheries Centre workshop on 'The use of ecosystem models to investigate multispecies management strategies for capture fisheries'. Thanks also to the Japanese Government who financed FA for this activity; and to the National Polytechnic Institute, Mexico, for partial support through CEGEPI-980056 project, COFAA and EDI; and to CONACyT through the project 34865-B.

### Literature cited

- Calderon-Aguilera L.E. y J.C. Burgueño 1993. Análisis y evaluación de la situación actual de la pesquería de camarón (*Penaeus* sp) en el Golfo de California. Comunicaciones Académicas. Serie Ecología CICESE CICT 9301.
- Calderon Aguilera, L.E. y J.R. Campoy Favela 1993. Bahía de Las Guasimas, Estero Los Algodones Y Bahía de Lobos, Sonora. Pages 411-419 in: Biodiversidad marina y costera de México. S.I. Salazar Vallejo y N.E. González (eds). Com. Nal. Biodiversidad y CIQRO, México, 865 pp.
- Christensen, V., C.J. Walters, and D. Pauly. 2000. Ecosystem with Ecosim Version 4, Help system©. Univ. of British Columbia, Fisheries Centre, Vancouver, Canada and ICLARM, Penang, Malaysia.
- Edwards, R. R. C. 1978. Ecology of a coastal lagoon complex in Mexico. Estuarine and Coastal Marine Science. 6:75-92.
- Lavin, M., E. Beier and A. Badan. 1997. Estructura Hidrográfica y Circulación del Golfo de California: Escalas Estacional e Interanual. In: M.Lavin (Ed.) Contribuciones a la Oceanografía Física en México. Monog.3. U. Geofísica Mex., pp. 139-169.

López-Martínez, J. 2000. Dinámica de camarón (*Penaeus californiensis*) en el litoral sonorensé y su relación con algunos parámetros oceano-atmosféricos. Tesis Doctor en Ciencias, Centro Interdisciplinario de Ciencias Marinas del IPN, México. 174p.

Mathews C.P. 1981. A review of the North American penaeid fisheries, with particular reference to Mexico. Kuwait Bulletin of Marine Science 2: 325-409.

Nevárez-Martínez, M.O. 2000. Variabilidad de la población de sardina monterrey (*Sardinops caeruleus*) en el Golfo de California, México. Tesis Doctor en Ciencias, Centro Interdisciplinario de Ciencias Marinas del IPN, México. 103p.

Pauly, D. (Editor). 1998. Use of Ecopath with Ecosim to evaluate strategies for sustainable exploitation of multi-species resources. Fisheries Centre Research Reports 6(2). 49 p.

Perez-Mellado, J.L. and L.T. Findley. (1985). Evaluación de la Ictiofauna del camarón capturado en las costas de Sonora y norte de Sinaloa, México, Cap.5:201-254. In: Yañez-Arancibia, A. (Ed) Recursos Pesqueros Potenciales de México: La pesca acompañante del camarón. Progr. Univ. de Alimentos, Inst. Cienc. del Mar y Limnol., I.N.P., UNAM, México D.F. 748 P.

Snyder-Conn E. and R.C. Brusca. 1975. Shrimp population dynamics and fishery impact in the northern Gulf of California. 1967-1968. Ciencias Marinas, 2 (2): 54-67.

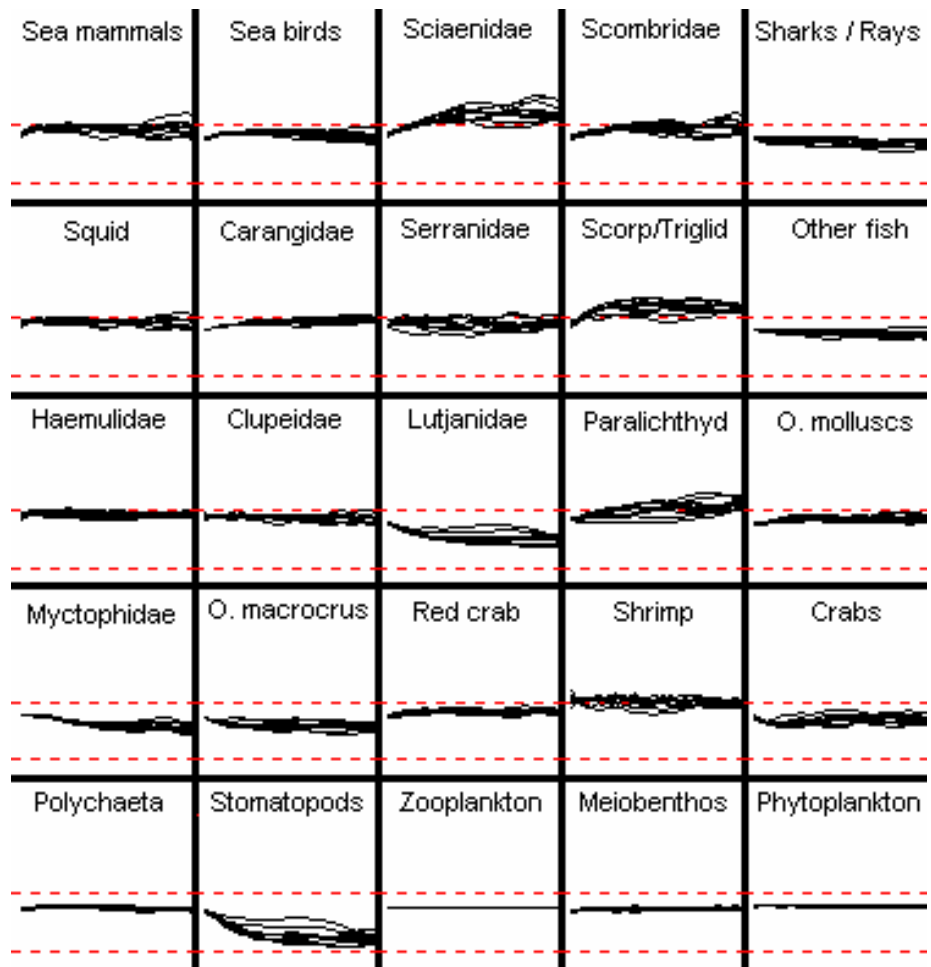

**Figure. 5** Simulated biomasses from close loop simulation for Strategy 4 (optimizing economic, jobs and ecosystem criteria), assigning B/P ratio as weighting factor for each group to emphasize ecosystem criteria. Simulations were running considering a) uncertainty on biomass per group as CV = 20%. b) Relative impact of fleets using factor of 3, 2 and 1 for shrimp, sardine and small-scale, respectively. c) Catchability increases a maximum of 5%, 10% and 15% for small-scale, shrimp and sardine fleets. d) Reference biological level of biomass (dashed lines) are fixed at 0.5B and 2.0B.



## Testing responses of a tropical shelf ecosystem to fisheries management strategies: a small-scale fishery from the Colombian Caribbean Sea

Luis Orlando Duarte<sup>1</sup> and Camilo B. García<sup>2</sup>

<sup>1</sup> *Universidad de Concepción, Chile*

<sup>2</sup> *Universidad Nacional de Colombia, Santa Marta, Colombia.*

### Abstract

A mass balance model (Ecopath II) was constructed for the Gulf of Salamanca, a Colombian Caribbean shelf ecosystem, using mostly local information collected during 1997. The biological structure and social and economical characteristics of the artisanal fisheries were included in the analysis. Based on this model, responses of the ecosystem and the fishing performance were tested over 20-year Ecosim simulations. Four fishery management scenarios maximized three independent objective functions (fisheries profits, employment, and ecosystem structure) and the combination of the three objectives together. The social objective simulation (employment) resulted in the most marked changes in the biomass distribution of the ecosystem components: predatory fishes, mullets/catfishes and croakers/mojarras fell below 20 percent of their baseline values of biomass; whereas small pelagic fishes, triggerfishes/filefishes and snappers/grunts increased more than two times their baseline values of biomass. Pelagic predatory fishes and mullets/catfishes groups were removed in the economic (fisheries profits) and social maximizing simulations. Including likely errors of stock assessment methods and their implementation (closed loop simulations) would indicate risk to fall below 20% of the initial biomass throughout the time of simulation for croakers/mojarras and porgies/spadefishes during the economic maximizing simulation and large demersal fishes during the social maximizing simulation. The social objective simulation generated the lowest predicted economic value of the landings and the largest declines in the mean trophic level of the ecosystem. Good performance for ecosystem structure (no collapsed species), the economic value of the predicted landings and employment, were obtained maximizing the combination of the three functions.

### Introduction

An artisanal fishery with few restrictions or controls uses the Caribbean Coast in Colombia. Recent trends of reduction of catches by the artisanal fishery in the Colombian Caribbean coast in the last decade (5886 tones landed in 1986 to 4616 tones landed in 1995, INPA 1995) have made clear the need for implementing management measures.

The Gulf of Salamanca (GofS) ecosystem (11° 00' N to 11° 19' N and 74° 12' W to 74° 50' W; Fig. 1) is an example of the Colombian Caribbean shelf ecosystems according to its biological and physical structure and the social and economical characteristics of the artisanal fisheries operating in this area. For the GofS, an expansion of the artisanal fishery depth range (at present within 0 to 50-m depth limit) has been proposed. The system and its fisheries are multispecific. The management policy should take into consideration this condition owing to the non-selective fisheries operating in the Gulf (García *et al.* 1998)

In addition, the comparison of this tropical shelf system with other similar systems might reveal some general ecosystem trends and characteristics useful in integrated management.

**Table 1.** Input parameters for the trophic modeling of the Gulf of Salamanca. Parameters calculated by ECOPATH II are presented in italics/shading. Fishes and epifauna biomass were estimated by the swept area method from the captures with bottom trawl samples. Zooplankton and infauna biomass were derived from sampling results of plankton nets and dredge respectively. Fishes P/B ratio were included as equivalent of the total mortality (Allen, 1971). Fishes Q/B ratio were computed by means of the empirical model of Palomares and Pauly (1998) (García and Duarte, *in press*). Parameters obtained from the literature are indicated: a- Arregin-Sanchez *et al.* 1993; b- Polovina 1984; c- Manickhand-Heileman *et al.* 1998; d- Wolff *et al.* 1998; e- Osorio 1997; f- Manjarres *et al.* 1993; g- Tijaro *et al.* 1998; h- Sánchez *et al.* 1998; i- Chrisholm and Roff 1990. The predator-prey matrix was constructed basically from fish stomach content analysis. This trophic information was gathered in digital format (CD; Duarte *et al.* 1999).

	GROUP	B	P/B	Q/B	EE
1	Phytoplankton	<i>10.080</i>	102.56 <sup>a</sup>	-	0.700
2	Macrophytes	<i>0.053</i>	11.00 <sup>b</sup>	-	0.700
3	Zooplankton	6.290	18.70 <sup>i</sup>	125.41 <sup>a d</sup>	<i>0.643</i>
4	Infauna	15.000	7.00	27.00 <sup>a</sup>	<i>0.975</i>
5	Epifauna	5.000	5.00 <sup>c d</sup>	19.00 <sup>a</sup>	<i>0.868</i>
6	Shrimps	0.704	7.57 <sup>a</sup>	28.00 <sup>d</sup>	<i>0.900</i>
7	Crabs	1.300	3.80 <sup>c</sup>	14.16 <sup>a</sup>	<i>0.836</i>
8	Small pelagic fishes	<i>0.835</i>	3.37 <sup>e f</sup>	18.98	0.900
9	Small demersal fishes	0.800	2.30	8.55	<i>0.847</i>
10	Large demersal fishes	0.270	0.60	6.00	<i>0.744</i>
11	Pelagic pred. fishes	0.330	0.91	8.80	<i>0.956</i>
12	Rays/Sharks	0.040	0.60 <sup>c d</sup>	5.30 <sup>a d</sup>	<i>0.050</i>
13	Mulletts/Catfishes	0.150	1.00 <sup>g h</sup>	4.50	<i>0.859</i>
14	Croackers/Mojarras	0.120	1.58	15.30	<i>0.971</i>
15	Porgies/Spadefishes	0.280	0.76	11.85	<i>0.924</i>
16	Trigger & file fish	0.480	0.80	7.39	<i>0.532</i>
17	Snappers/Grunts	0.450	0.89	6.99	<i>0.839</i>
18	Detritus	-	-	-	<i>0.666</i>

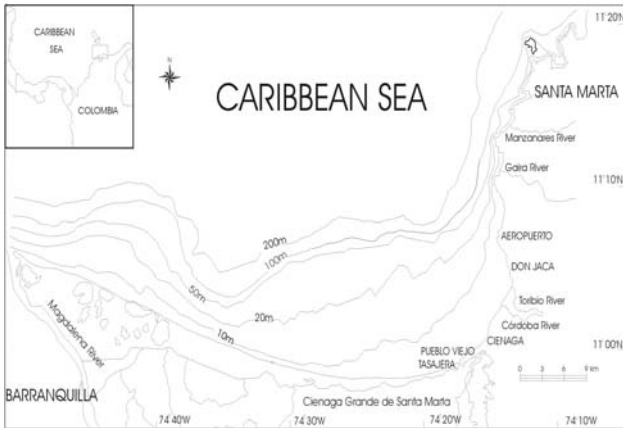

**Figure 1.** Study area, Gulf of Salamanca. A relatively small area (955 km<sup>2</sup>) located in the central Colombian Caribbean Coast.

Fishery management cannot be tackled by fishery biologists alone. The scientific community involved in management of ecosystems has recognized the importance of including scientific, social and economic criterion in the management schemes (Mangel *et al.* 1996). Therefore, multi-

variate and interdisciplinary evaluations are needed to explore management policies.

In this context, the dynamic ecosystem simulation included in Ecopath with Ecosim software (Walters *et al.* 1997, 2000) was used to test potential management strategies in order to investigate whether the GofS fishery can be sustained and have economic importance. Four scenarios were evaluated over a 20-year simulation period: maximizing three independent objective functions (fisheries profits, employment, and ecosystem structure) and maximizing the combination of these three functions.

**Data Information Sources**

A mass balance model of 18 compartments for the GofS was constructed during 1997 using Ecopath II (Christensen and Pauly 1992; Fig. 2). The input parameters were mostly obtained from local information collected in three scientific cruises (February, July and November) carried out on the continental shelf (10 to 200 m depth; Table 1).

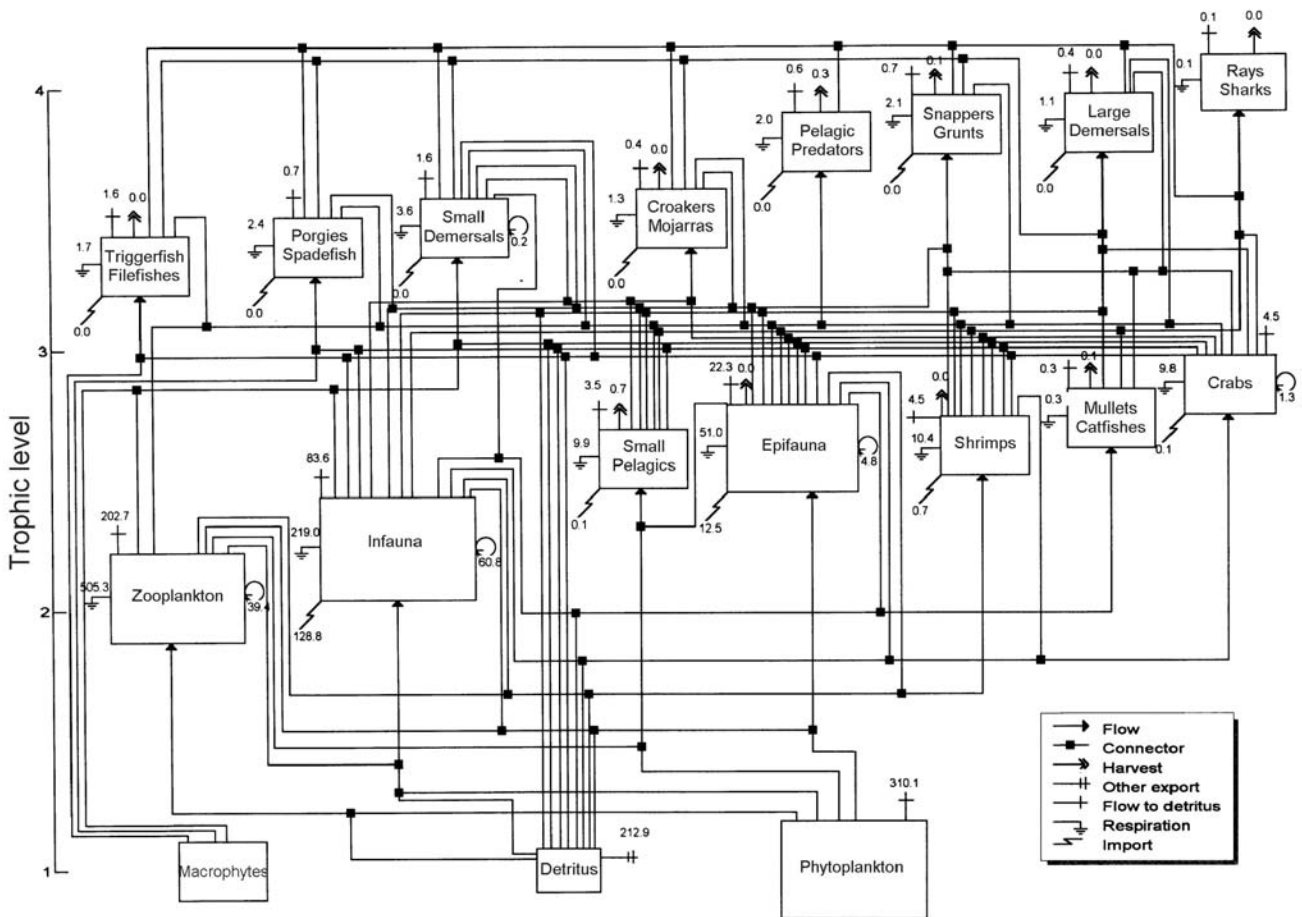

**Figure 2.** A balanced trophic model of the Gulf of Salamanca ecosystem for 1997. All flows are in t/km<sup>2</sup>/year. The surface area of the boxes is proportional to the logarithm of the biomass represented.

**Table 2.** Inventory of the fishing economical units of the Gulf of Salamanca, taken by INPA and INPA-VECEP/UE program (Dec. 1996 - Jan. 1997). Geographical location of landing towns is shown in Figure 1.

Landing town	Boat type				Fishing gear			
	Wood	Syn- thetic	Motor	Oar and Sail	Gill- nets	Fishing lines	Beach seines	Long lines
Tasajera	37			37	10		27	
Pueblo Viejo	95		22	73	22	35		
Cienaga	32	12	20	24	9	6		
Papare	11			11	11			
Don Jaca	8	3	3	8	10		1	7
Aeropuerto	3			3	2	1		6
Total	186	15	45	156	64	42	28	13

The model emphasizes demersal and benthic ecological groups due to the sampling methods used and the economic importance of these groups. The fished groups and their most important components included in the analysis were: epifauna (*Panulirus argus* Latreille 1804), shrimps (*Xiphopenaeus kroyeri* Heller 1862), small pelagic fishes (*Cetengraulis edentulus* Cuvier 1829), small demersal fishes (*Syacium*, *Polydactylus*), large demersal fishes (*Elops*, *Epinephelus*), pelagic predatory fishes (*Sphyraena*, *Scomberomorus*, *Caranx*), croakers/mojarras (*Micropogonias*, *Menticirrhus*, *Diapterus*), porgies/spadefishes (*Calamus*, *Chaetodipterus*), triggerfishes/ filefishes (*Balistes*, *Aluterus*) and snappers/grunts (*Lutjanus*, *Conodon*).

The fisheries input information is the product of the fishing assessment program developed by the Instituto Nacional de Pesca y Acuicultura (INPA) and the VECEP-UE fisheries program. This information was gathered and analyzed by García *et al.* (1999)

Table 2 shows the inventory of the fishing eco-

**Table 3.** Ten most captured components by the artisanal fisheries in the Gulf of Salamanca between May 1993 and May 1998. Landings recorded by INPA and INPA-VECEP/UE program.

Scientific name	Local name	Common name*	Catch (Kg)	% Total Catch	Accum. % Catch
<i>Cetengraulis edentulus</i>	Bocona	Atlantic anchoveta	3548046	55.395	55.395
<i>Sphyraena guachancho</i> , <i>S. picudilla</i> , <i>S. barracuda</i>	Picuas	Barracudas	484721	7.568	62.963
<i>Caranx bartholomei</i> , <i>C. crysus</i> , <i>C. ruber</i>	Cojinoas	Jacks	345567	5.395	68.358
<i>Caranx hippos</i> , <i>C. latus</i>	Jureles	Jacks	337145	5.264	73.622
<i>Scomberomorus brasiliensis</i> , <i>S. regalis</i>	Carite	Mackerels	309754	4.836	78.458
<i>Conodon nobilis</i>	Coco	Barred grunt	290653	4.538	82.996
<i>Lutjanus spp.</i> (1), <i>R. aurorubens</i> , <i>O. chrysurus</i> , <i>P. aquilonaris</i> , <i>L. maximus</i>	Pargos	Snappers	204123	3.187	86.183
<i>Micropogonias furnieri</i> , <i>Menticirrhus americanus</i> , <i>Menticirrhus littoralis</i>	Coroncoros	Croakers	157265	2.455	88.638
<i>Ariopsis bonillae</i> , <i>Arius proops</i> , <i>Bagre marinus</i> , <i>Cathorops spixi</i>	Chivos	Sea catfishes	152381	2.379	91.017
<i>Mugil incilis</i>	Lisa	Parassi mullet	145025	2.264	93.282
Others (at least 97 species).			155469	6.718	100.000

(1) *L. synagris*, *L. griseus*, *L. cyanopterus*, *L. analis*, *L. bucanella*, *L. vivanus*, *L. jocu*, *L. purpureus*, *L. mahogoni*, *L. apodu*

\* From: Cervigon *et al.* (1992)

conomic units between December 1996 and January 1997 in the GofS. Wooden boats moved with oars and/or sails predominate. The most common fishing unit uses gillnets and the town with the greatest number of fishing units is Pueblo Viejo (see Fig. 1).

Table 3 shows the list of the ten most abundant species in the landings and their relative importance between 1993 and 1998. An estimate of 6400 tons of invertebrates and fishes has been extracted in the GofS during this period. There is a high diversity in the landings with more than 100 species, although ten groups represent more than 90% of the total capture. In fact, the Atlantic anchovy (*Cetengraulis edentulus*) represents more than 55 % of total landings. It is a low economic value species since it is used as fresh food for crocodile farming. No discards are reported for the Gulf. The low value species are sustenance for fishermen.

General groups according to local names that include several species or genera (García 1999) are registered in the landings. This is a common problem in the Caribbean and constitutes a challenge to devising possible fishery management schemes (Christensen and Mahon 1997).

**Table 4.** Landings (t/km<sup>2</sup> in 1997) of the groups included in the Ecopath model used for the simulation. Local fishermen provided the landed values. Employment factor is proportional to the jobs/catch ratio.

Group Name	Beach seine	Gill net	Long line	Fishing line	Total	Landed value (US\$/Ton)
Epifauna	-	0.001	-	-	0.001	5514.09
Shrimps	0.005	-	-	-	0.005	4848.91
Small Pelagic fishes	0.690	0.005	-	-	0.695	250.00
Small Demersal fishes	-	-	0.0002	-	0.0002	200.00
Large Demersal fishes	0.001	0.011	0.007	0.003	0.022	3071.79
Pelagic Predatory fishes	0.081	0.118	0.001	0.073	0.273	2164.85
Rays/Sharks	-	-	0.001	-	0.001	1692.71
Mulletts/Catfishes	0.002	0.025	0.009	0.018	0.054	2020.62
Croakers/Mojarras	-	0.017	0.004	-	0.021	3153.38
Porgies/Spadefishes	-	-	0.001	-	0.001	2821.18
Triggerfishes/Filefishes	-	-	0.002	-	0.002	493.71
Snappers/Grunts	0.003	0.003	0.054	0.047	0.107	3568.80
Sum	0.782	0.18	0.079	0.141	1.182	-
Employment factor	1.00	1.50	1.15	0.83		

Table 4 shows the captures of each of the components of the model used in the simulation separated by fleet, for the year 1997. The beach seines reported the greatest volume of landings because they capture almost all the small pelagic fishes and an important fraction of the pelagic predatory fishes, the second most abundant group in the landings. The higher economic value groups were epifauna (spiny lobsters), shrimps and snappers/grunts. Using factors derived from jobs/catch ratios for each gear, gill nets and long lines had the higher importance for employment.

**Methods**

*Ecosim Model Parameters*

The dynamic simulation model, Ecosim (Walters *et al.* 1997, 2000), requires some parameters in addition to those used for Ecopath. This study assumed default values for all settings of Ecosim except for the trophic vulnerabilities. These parameters measure rates with which prey move be-

tween vulnerable and non-vulnerable states to their predators. Low vulnerability rates imply bottom-up and high rates top-down control. Ecosim predictions are sensitive to this set of parameters (Walters and Christensen 2000). In tropical systems, top-down effects could be enhanced by the increased food consumption rates of predators in relation with the water temperature (Pauly 1998).

On the other hand, the positive impact of detritus and lower trophic levels on other groups in some tropical systems (Wolff *et al.* 1998, Manickhand-Heileman *et al.* 1998) suggest bottom-up control in the food web. In order to consider both bottom-up and top-down potential effects, the vulnerability rates were derived in relation to the trophic level of each group in this study (T. Pitcher pers. comm.). The lower vulnerability value included (0.2) was assigned to the lower trophic level of the system (1 - phytoplankton), and conversely, the higher vulnerability (0.8) to the higher trophic level (4 - rays/sharks). The remaining groups were scaled between these extreme values. In addition, two intermediate control levels assigned for the entire ecosystem (0.4 and 0.6) were explored and the results of their performance indicators were compared.

*Objective Functions*

A nonlinear optimization procedure to search for

**Table 5.** Average annual biomass and landings by group calculated over 20 years of Ecopath with Ecosim simulations for each maximising function. The values are relative to the baseline simulation parameters. Vulnerabilities were assigned as a function of their trophic level.

Group	Function	Net Economic value		Ecosystem structure		Social value		Compromise	
		Biomass	Catch	Biomass	Catch	Biomass	Catch	Biomass	Catch
Epifauna		0.98	2.88	1.00	0.96	0.83	8.94	0.97	3.60
Shrimps		1.58	1.80	0.99	1.02	1.49	1.24	1.55	1.85
Small Pelagic fishes		2.16	2.15	0.98	1.00	3.90	0.49	1.95	1.99
Small Demersal fishes		0.62	0.11	1.01	1.02	0.93	4.04	0.67	1.31
Large Demersal fishes		1.91	4.40	0.99	0.97	0.34	2.41	1.44	4.04
Pelagic Predatory fishes		0.06	0.14	1.03	1.00	0.02	0.07	0.12	0.27
Rays/Sharks		1.23	2.41	1.00	0.98	1.62	6.52	1.20	2.25
Mulletts/Catfishes		0.12	0.32	1.03	1.00	0.03	0.19	0.15	0.38
Croakers/Mojarras		0.38	1.08	1.00	0.97	0.14	1.36	0.31	1.08
Porgies/Spadefishes		0.60	0.11	1.00	1.01	1.69	7.33	0.69	1.36
Triggerfishes/Filefishes		1.85	0.33	0.99	1.00	2.36	10.23	1.82	3.46
Snappers/Grunts		2.27	3.98	0.98	0.97	2.15	5.59	2.45	3.64
Total		1.02	1.78	0.99	1.00	1.04	0.94	1.02	1.69

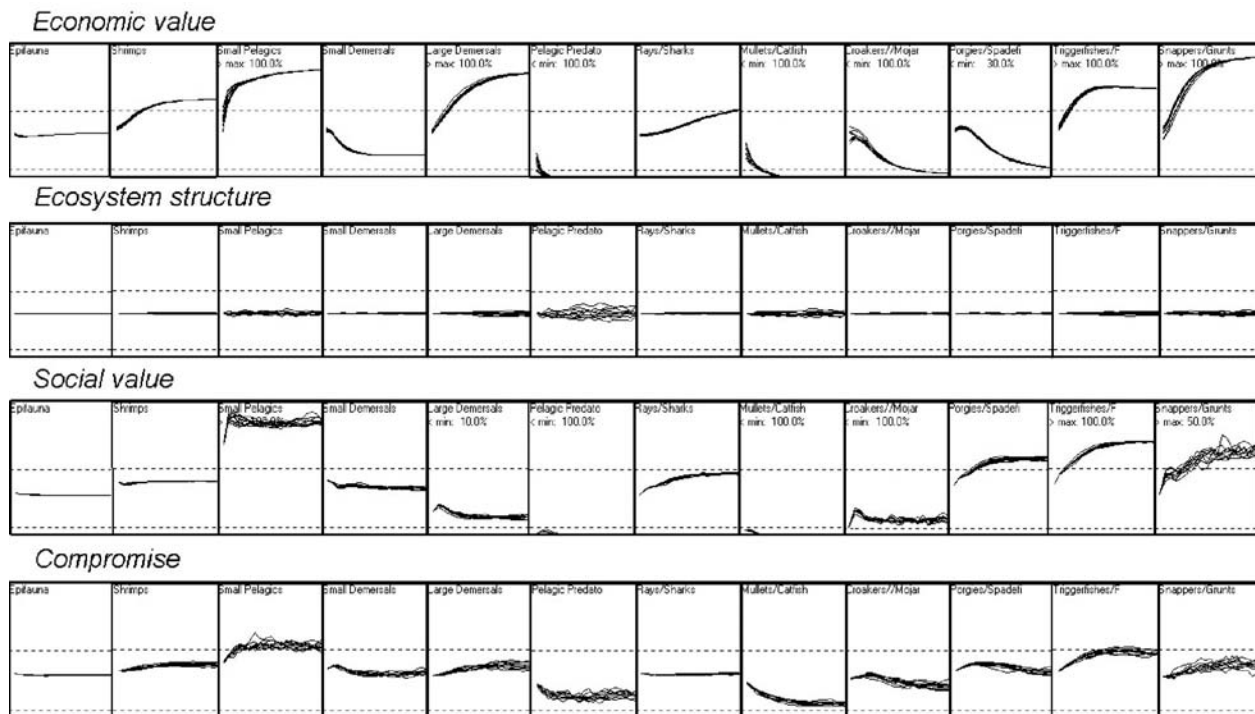

**Figure 3.** Closed loop simulations of the predicted biomass trajectories for the fished groups. Segmented lines are boundary levels for analysing risk of exceeding during runs. For this study the lower and upper limits are defined as 20% and 200% of the initial biomass value respectively. Percentages of the total runs exceeding the upper limit (>max) or falling below the lower limit (<min) are indicated.

fishing policies that maximize a particular policy goal for management is included in Ecosim as describe by Christensen *et al.* (2000). The objective functions maximized during the simulations were the employment factor (jobs/catch) for the social goal, the fisheries profits for the economic goal and the reciprocal of P/B ratio of each group as the ecological structure objective.

For the combination of the three functions (compromise scenario), equal weighting values (1-1-1) for all three objective functions underweight the ecological component effect. Economic and social components were lowered systematically (until 0.25) to get a “legitimate” effect, i. e. a nearly equitable compromise between the social, economic and ecological effects in the performance indicators used here (see results).

**Table 6.** Performance indicators calculated over the simulation period for each maximising function. Vulnerabilities were assigned as a function of to their trophic level.

Objective Function	Economic Value	Ecosys-tem stability	Social Value	The big compromise
Fished groups below 20% start biomass	4	0	4	0
Fished groups above 60% start biomass	7	12	8	9
Total average biomass (t/km <sup>2</sup> /y)	64.49	62.80	66.01	64.27
Total average Landings (t/km <sup>2</sup> /y)	2.11	1.18	1.12	2.01
Mean trophic level of the ecosystem (w/o detritus)	2.10	2.07	1.88	2.10
Mean trophic level of landings	2.96	3.04	3.43	2.97

Graphical representations of the change of the biomasses of the fished groups over the time were made up from the outputs of the closed-loop simulations routine of Ecosim. This routine is a Monte-Carlo simulation that includes random errors associated with stock assessment and regulatory process dynamics (Christensen *et al.* 2000).

**Results and Discussion**

Average annual biomasses and landings for the simulation period and relative to the baseline conditions are presented for each management strategy in Table 5. Total average biomasses changed little during the simulation in all scenarios. Total average catches were highest in economic and ‘big compromise’ scenarios.

Marked changes in the biomass partition of the ecosystem components resulted from the social and economic objective function simulation. The average annual biomass of three groups (pelagic predatory fishes, mullets/catfishes

**Table 7.** Performance indicators calculated over the simulation period for each maximising function when vulnerabilities of 0.6 were assigned to all groups. Predicted fishing rates and economical values are relative to the baseline simulation parameters.

Objective Function	Economic Value	Ecosystem stability	Social Value	'Big compromise'
Fished groups below 20% start biomass	5	4	5	5
Fished groups above 60% start biomass	7	7	7	7
Total average biomass (t/km <sup>2</sup> /y)	71.65	68.56	71.14	70.05
Total average landings (t/km <sup>2</sup> /y)	1.39	3.46	1.27	2.75
Mean trophic level of the ecosystem (- detritus)	2.10	2.08	2.10	2.09
Mean trophic level of landings	3.63	2.90	3.68	2.96
Predicted Fishing Rate of Beach Seine	0.1	1	0	1.1
Predicted Fishing Rate of Gill net	5.2	1.6	6.5	1.8
Predicted Fishing Rate of Long line	0.5	1.5	4.2	1.8
Predicted Fishing Rate of Fishing line	4.5	2.2	0	1.9
Predicted Economic Value	1.52	1.29	0.89	1.04

and croakers/mojarras) fell below 20% of the baseline biomass during the social maximizing simulation and two groups (pelagic predatory fishes and mullets/catfishes) fell below 20% of the baseline biomass during the economic maximizing simulation. In contrast, some groups experienced increased biomass (small pelagic fishes, triggerfishes/filefishes, snappers/grunts) in spite of the high fishing pressure (see Table 5). This optimistic result suggests that the lower predation pressure, as consequence of both removing predators and competitors, exceed the fishing pressure for these groups. Ecological structure and compromise scenarios did not generate extreme values in the group's average biomasses during the simulations. Apparently, the ecological structure weight settings applied here tend to maintain the baseline biomasses and landings.

The closed loop simulations reinforce the changes in the average annual biomasses described above and predict some additional changes in the biomass trajectory of other groups (see Fig. 3).

This is the case of croakers/mojarras and porgies/spadefishes during the economic maximizing simulation and large demersal fishes during the social maximizing simulation. For these groups, the incorporation of the dynamics of the stock assessment would indicate a higher risk of falling below 20% of the initial biomass throughout the time of simulation than the

**Table 8.** Performance indicators calculated over the simulation period for each maximising function when vulnerabilities of 0.4 were assigned to all groups. Predicted fishing rates and economical values are relative to the baseline simulation parameters.

Objective Function	Economic Value	Ecosystem stability	Social Value	'big compromise'
Fished groups below 20% start biomass	2	0	2	0
Fished groups above 60% start biomass	11	13	11	11
Total average biomass (t/km <sup>2</sup> /y)	63.62	63.13	61.36	63.31
Total average Landings (t/km <sup>2</sup> /y)	2.10	1.42	0.70	1.38
Mean trophic level of the ecosystem (w/o detritus)	2.08	2.08	1.84	2.08
Mean trophic level of landings	2.94	2.98	3.52	3.01
Predicted Fishing Rate of Beach Seine	1.3	0.7	0	1.1
Predicted Fishing Rate of Gill net	4	1.1	6.8	1.2
Predicted Fishing Rate of Long line	1.6	0.8	5.3	1.2
Predicted Fishing Rate of Fishing line	3.6	1.3	0	1.2
Predicted Economical Value	0.76	0.97	0.77	0.7

search procedure results of the optimization method or 'open loop policy analysis' (specially in croakers/mojarras for the economic maximizing scenario where 100% of the runs fell below the 20% of the initial biomass, see Figure 3).

Catches of high value groups were increased in the economic scenario, while in the social and compromise scenarios catches of several groups were increased.

Fishing rates of gill nets and long lines were increased by a factor of 15.9 and five respectively in the social objective function simulation. These fishing rates were heavily decreased in the other simulation scenarios (Table 6). Predicted catches and economic values were higher in the economic scenario. In contrast, the social objective simulation generated the lowest predicted economic value (Table 6).

High biomasses and catches that are predicted for other high value groups should be regarded with caution. The decrease of the total prey mortality owing to the elimination of one predator may be compensated by increase in the vulnerability to other predators due to changes in behavioral or physiological states of preys and/or enlargement of the time exposed to predators (Christensen and Walters 2000).

The results of the analysis presented here show a strong social pressure in the system and reinforce the urgency of a monitoring plan for the GofS to avoid potential Malthusian overfishing (Pauly *et*

al. 1989).

This study represents the first exploratory analysis addressing ecosystem management strategies for Colombia. Independent information to validate the simulations will be needed. Further studies, confirmation and refinement of input parameters will be needed to explore the ecosystem responses in more detail. At the end the decision about which management strategy is the best to apply will always be a political one, but at least we hope it will be an informed one.

### Acknowledgements

We are grateful to Prof. T.J. Pitcher for the invitation to attend the FAO/UBC Fisheries Centre Workshop and for his hospitality, support and interest. We thank Fisheries Centre/University of British Columbia for sponsoring the participation in the Workshop. Financial support for L.O. Duarte is given by a Ph. D. scholarship from the Deutscher Akademischer Austauschdienst (DAAD). Research was funded by the Fondo Colombiano de Investigaciones Científicas, COLCIENCIAS (Project cod. 2105-09-176-94) and the Instituto de Investigaciones Marinas y Costeras, INVEMAR. E. Vilorio provided some social information from the GofS fisheries.

### References

- Allen, R. 1971. Relation between production and biomass. *J. Fish Res. Board Can.* 28: 1573-1581.
- Arreguin-Sánchez, F., E. Valero-Pacheco and E. A. Chávez. 1993. A trophic box model of the coastal fish communities of the southwestern Gulf of Mexico, Pages 197-205 in: Christensen V. and D. Pauly (eds) *Trophic Models of Aquatic Ecosystems*. ICLARM Conf. Proc. 26: 390 pp.
- Cervigon *et al.* (ten authors) 1992. Fichas FAO de identificación de especies para los fines de pesca. Guía de campo de las especies comerciales marinas y de aguas salobres de la costa septentrional de Sur América. CCE. NORAD. FAO. 513 pp.
- Chrisholm, L.A. and J.C. Roff 1990. Abundances, growth rates, and production of tropical neritic copepods off Kingston, Jamaica. *Marine Biology* 106: 79-89.
- Christensen, V. and D. Pauly 1992. ECOPATH II - a software for balancing steady-state models and calculating network characteristics. *Ecol. Modelling* 61:169-185.
- Christensen, V. and R. Mahon 1997. Researchable issues relevant for management of large marine ecosystems, with special reference to the Caribbean. ACP-EU Fisheries Research Report (3): 79-100.
- Christensen, V. and C. Walters 2000. Ecopath with Ecosim: Methods, Capabilities and Limitations. In D. Pauly and T.J. Pitcher (eds) *Methods for assessing the impact of fisheries on marine ecosystems of North Atlantic*. Fisheries Centre Research Reports 8(2): 195 pp).
- Christensen, V., C.J. Walters and D. Pauly 2000. *Ecopath with Ecosim: a User's Guide*, October 2000 Edition. Fisheries Centre, University of British Columbia, Vancouver, Canada and ICLARM, Penang, Malaysia, 130 pp.
- Duarte, L.O., C.B. García and I. Moreno (con contribución de G. Melo, P. Navajas, N. Sandoval y D. Von Schiller) 1999. Atlas demográfico de los peces demersales del Golfo de Salamanca, Caribe Colombiano. Dinámica Poblacional, Distribución, Alimentación y Reproducción. Digital book CD. Invemar - Colciencias. ISBN 95950-6-5.
- García, C.B., L.O. Duarte and D. von Schiller 1998. Demersal fish assemblages of the Gulf of Salamanca, Colombia (southern Caribbean Sea). *Mar. Ecol. Prog. Ser.* 174: 13-25.
- García, C.B., M. Barros. and L. Manjarres 1999. Descripción de mediano plazo de las pesquerías del Golfo de Salamanca: Primera aproximación. Pages 20-51 in C.B. García (ed.). *Estudio integral del Golfo de Salamanca, Caribe Colombiano*. Technical Report to COLCIENCIAS, Volume II.
- García, C.B. and L.O. Duarte In press. Caribbean fishes Consumption/Biomass (Q/B) ratios and Q/B-predictor variable values. NAGA ICLARM Q.
- García, C.B. 1999. Incorporating ecosystem modelling into fisheries research: a case study from Colombia. ACP-EU Fisheries Research Report 5: 34-35.
- Larkin, P.A. *et al.* (ten authors). 1984. Strategies for Multispecies Management. Group Report. Pages 287-301 in: R.M. May (Ed.) *Exploitation of Marine Communities*. Dahlem Konferenzen. Springer-Verlag.
- Mangel, M. *et al.* (43 authors) 1996. Principles for the conservation of wild living resources. *Ecol. Appl.* 6(2): 338-362.
- Manickhand-Heileman, S., F. Arreguin-Sánchez, A. Lara Dominguez and L.A. Soto 1998. Energy flow and network analysis of Terminos Lagoon, SW of Gulf of Mexico. *Journal of Fish Biology* 53 (Supplement A): 179-197.
- Manjarres, L., J. Infante and A. Rueda 1993. Parámetros biológico-pesqueros del machuelo (*Opisthonema oglinum*), el ojo gordo (*Selar crumenophthalmus*), el pargo rayado (*Lutjanus synagris*) y el carite (*Scomberomorus brasiliensis*), con miras a regular sus capturas con redes de enmalle. P 63-68 in Proyecto integral de investigaciones y desarrollo de la pesca artesanal marítima en el área de Santa Marta. Informe técnico final INPA, CIID, UNIMAGDALENA.
- Osorio, D. 1997. Estudio biológico pesquero de *Cetengraulis edentulus* Cuvier 1820 (Pisces, Clupeiformes) y algunas consideraciones ecológicas. Sector costero Isla de Salamanca, Caribe Colombiano. 155 p.
- Palomares, M. and D. Pauly 1998. Predicting food consumption of fish populations as functions of mortality, food type, morphometrics, temperature and salinity. *Mar. Freshwater Res.* 49: 447-453.
- Pauly, D. 1998. Tropical fishes: patterns and propensities. *Journal of Fish Biology* 53 (Supplement A): 1-17.
- Pauly, D., G. Silvestre and I.R. Smith 1989. On development, fisheries and dynamite: a brief review of tropical fisheries management. *Natural Resources Modeling* 3(3): 307-329.
- Polovina, J.J. 1984. Model of coral reef ecosystems. I

- the ECOPATH model and its application to French Frigate Shoals, NOAA, Honolulu. Adm. Rep. No. 83-23. 46 pp.
- Sánchez, C., M. Rueda and A. Santos 1998. Dinámica poblacional y pesquería de la lisa, *Mugil incilis* Hancock, en la Ciénaga Grande de Santa Marta, Caribe Colombiano. Rev. Acad. Colomb. Cienc. 22(85): 507-517.
- Tijaro, R., M. Rueda and A. Santos 1998. Dinámica poblacional del chivo mapalé *Cathorops spixii* en la Ciénaga Grande de Santa Marta y complejo de Pajarales, Caribe Colombiano. Bol Invest. Mar. Cost. 27(11): 87-102.
- Walters, C.J., V.Christensen and D.Pauly 1997. Structuring dynamic models of exploited ecosystems from trophic mass-balance assessments. Reviews in Fish Biology and Fisheries 7: 139-172.
- Walters C.J., J.F Kitchell, V.Christensen and D.Pauly 2000. Representing density dependent consequences of life history strategies in aquatic ecosystems: Ecosim II. Ecosystems 3: 70-83.
- Walters C.J. and V.Christensen 2000. Using independent information on historical stock depletions and maximum tolerable fishing mortality rates to provide bounds for trophic vulnerability parameters in Ecosim. (MS). Fisheries Centre, UBC. Vancouver. 9 p.
- Wolff, M., V.Koch, J.Bautista and J.A.Vargas 1998. A trophic model of the Golfo de Nicoya, Costa Rica. Rev. Biol. Trop. 46. Supl. 6: 63-79.
-



## Exploratory analysis of possible management strategies in Lake Victoria fisheries (Kenyan sector) using the recent Ecosim software

Jacques Moreau, and  
Maria Concepcion Villanueva  
INP/ENSAT, Castanet Tolosan, France

### Abstract

New developments in Ecosim, which is part of the well known Ecopath software have allowed the user to evaluate the effects of a range of possible fisheries management strategies for the Lake Victoria fisheries. The software is also used in this report to explore the fisheries and fish community of Lake Victoria. In particular, management strategies are explored aimed at achieving specified socio-economic objectives, including maximising the economic value of the ecosystem and maximising employment by altering the pattern of fishing effort by the fishing fleets comprising the Lake Victoria fishery. Further, the same approach was used to consider optimal management strategies from an ecological perspective.

### Introduction

Lake Victoria, East Africa has undergone dramatic changes in the structure of its ecosystem since the introduction of Nile perch, *Lates niloticus* (L.) more than thirty years ago (Wandera & Wanink, 1995). The initial multispecies stock of the lake has been replaced by three commercially important species: two totally demersal exotics, the Nile perch and Nile tilapia, *Oreochromis niloticus* (L.), and the native sardinelike, zooplanktivorous, pelagic cyprinid dagaa, *Rastrineobola argentea* (Pellegrin) (Bundy & Pitcher, 1995; Wilson *et al.*, 1997). The vast expansion of fish production in the lake associated with this shift has been due to the increased population of Nile perch at the end of the 1970s, at the expense of heavy predation on endemic species, resulting in the decimation of many haplochromid species (Reynolds and Greboval, 1995; Wilson *et al.*, 1997). The small cyprinid *R. argentea* is the only indigenous species of commercial economic importance remaining and became the major prey species of the Nile perch (Ogari & Dadzie, 1988).

This present paper is the follow-up of a previous contribution (Villanueva & Moreau 2000) in which ECOPATH was used in order to describe the trophic relationships occurring in the well documented and intensively exploited Kenyan

sector of the lake since the middle of the eighties. In this updated work it was possible to estimate the biomass, food consumption, trophic level and other parameters of the ecosystem, as well as to simulate with Ecosim the variations of both the biomass and actual catch from 1985-86 to 1995-96. This study also confirmed most of the ecological trends observed in the field and reported by several authors (Pitcher & Bundy, 1995; Mkumbo *et al.*, 2000).

### Methods

#### The Ecopath IV/Ecosim Software

To model the structure of trophic interactions occurring in the ecosystem, we used ECOPATH IV (Christensen and Pauly, 1992, 1993, and 1996; Walters *et al.*, 1997). The file which has been utilized is the one already documented in Villanueva and Moreau (2000). The current version of the software allows:

- the simulations of the variations in catch and biomass related to changes in fishing effort over time, a routine which is already known by several users of Ecopath and was used by Villanueva and Moreau (2000);
- the fitting of time series data of biomasses;
- the evaluation of the vulnerability coefficients of each group ;
- the fishing policy search options discussed Walters *et al.* (this volume).

#### Designing the present Ecopath/Ecosim database

The taxonomic groups considered here are those already identified in the previous contributions by Moreau *et al.* (1993) and Villanueva and Moreau (2000). The Nile perch *L. niloticus* was divided into separate adult and juvenile components to reflect differences in their specific P/B, Q/B and feeding habits. The necessary inputs for each group (P/B, Q/B, EE and the diet composition) have been documented in Villanueva and Moreau (2000).

The segregation of *Lates niloticus* group into juveniles and adults led to the division of the fish yield according to the fishing gears used, as documented by Wanink *et al.* (1999), Tweedle and Cowx (1999) and Njiru *et al.* (2000). In addition, reasonable economical data (personal communications from resident scientists in the riparian countries of the lake) have also been incorporated in the database: the selling prices of the exploited fish populations and the relative costs of the fishing operation with the fishing gears under utilization (see Table 1a and 1b).

**Table 1.** a) Landings from the Kenyan sector of Lake Victoria, East Africa (adapted from Mkumbo *et al.* 2000). Note that landings have been segregated among various current fishing gears for a proper utilization of Ecosim.

Group \ Catch	Lates long lines	Large mesh sizes	Small mesh sizes	Dagaa fisheries	Littoral lines	Total catch
Adult Lates n.	5	5				10
Juvenile Lates		1	2			3
Bagrus/Clarias					0.15	0.15
Protopterus					0.03	0.03
Morm./Synodont					0.03	0.03
Haplochr.Predat			0.01			0.01
Haplochr.Phytop			0.01			0.01
Haplochr.Bentho			0.02			0.02
<i>R.argentea</i>				6.4		6.4
<i>O.niloticus</i>		0.6	1			1.6
Other Tilapias			0.35			0.35
Total catch	5	6.6	3.39	6.4	0.21	21.6
Trophic level	3.61	3.42	2.8	2.83	3.19	3.19

b) The value, costs and profit by gear type for the Lake Victoria fishery in Kenya. The selling prices of the fish have been set as follows: 2 US\$ kg for Nile perch, 0.5 US\$ for haplochromids and native tilapia, and 1 US\$ per kilo for other groups including Nile tilapia.

Group name	Lates long lines	Large mesh sizes	Small mesh sizes	Dagaa fisheries	Littoral lines	Total value
Adult Lates n.	10	10				20
Juvenile Lates		2	4			6
Bagrus/Clarias					0.15	0.15
Protopterus					0.03	0.03
Morm./Synodont					0.03	0.03
Haplochr.Predat			0.01			0.01
Haplochr.Phytop			0.01			0.01
Haplochr.Bentho			0.01			0.01
<i>R.argentea</i>				6.4		6.4
<i>O.niloticus</i>		0.6	1			1.6
Other Tilapias			0.18			0.18
Total value	10	12.6	5.2	6.4	0.21	34.41

## Results

Table 2 shows the key features of the present Ecopath IV model and Table 3 summarizes the diet composition of the groups considered.

*The search for an optimum strategy (the open loop strategy simulation)*

This research involved the choice of relative weights reflecting the values attached to: the absolute financial value of the ecosystem; the social value (as reflected by total employment across all fisheries); and the stability and sustainability of the ecosystem as defined by the user (see Cochrane, this volume). This paper differs from the others in that it did not explore the default strategies (maximising each of economic, social and ecosystem goals separately and the 'big compromise' in which equal weight was given to

**Table 2.** Key features of the Ecopath model of the Kenyan sector of Lake Victoria, Africa for 1985-86. The trophic levels, food consumption flow to detritus, and the biomass for all groups (except aquatic birds) have been computed by the model. The input (P/B, Q/B and EE) are documented in Villanueva and Moreau (2000).

Group name	Trophic level	Habitat area	Biomass in habitat area (t/km <sup>2</sup> )	Biomass (t/km <sup>2</sup> )	Prod./biom. (year)	Cons./biom. (/year)	Ecotrophic efficiency	Prod./cons.
Fish eat. Birds	3.9	1	0.005	0.005	0.3	60	0	0.005
Adult Lates n.	3.6	1	10.526	10.526	1	5	0.95	0.2
Juvenile Lates	3.3	1	5.421	5.421	3.5	11.8	0.98	0.297
Bagrus/Clarias	3.2	1	1.637	1.637	0.9	6.5	0.95	0.138
Protopterus	3.2	1	1.532	1.532	0.3	4.3	0.95	0.07
Morm./Synodont	3.1	1	0.425	0.425	1	11.5	0.95	0.087
Haplochr.Predat	3.7	1	0.126	0.126	2.5	8.5	0.95	0.294
Haplochr.Phytop	2.1	1	0.214	0.214	3	41	0.95	0.073
Haplochr.Bentho	3	1	0.402	0.402	3	21	0.95	0.143
<i>R.argentea</i>	2.8	1	8.693	8.693	2.8	27	0.95	0.104
<i>O.niloticus</i>	2.1	1	12.019	12.019	0.95	24.6	0.95	0.039
Other Tilapias	2.1	1	1.146	1.146	1.2	32	0.95	0.038
Zooplankton	2	1	11.321	11.321	33.5	140	0.8	0.239
Lake prawn	2.3	1	5.562	5.562	16	64	0.95	0.25
Insects/Mollusc	2.1	1	24.879	24.879	5	25	0.8	0.2
Phytoplankton	1	1	5.327	5.327	365	-	0.95	-
Bent. Producers	1	1	13.99	13.99	25	-	0.95	-
Detritus	1	1	10	10	-	-	0.652	-

**Table 3.** Diet composition of the various groups for ECOPATH in Lake Victoria, Africa, as documented in Villanueva and Moreau (2000).

Prey \ Predator	1	2	3	4	5	6	7	8	9	10	11	12	13	14	15
1 Fish eat. Birds															
2 Adult Lates n.															
3 Juvenile Lates		0.25	0.03	0.04	0.01	0.005									
4 Bagrus/Clarias		0.02		0.01	0.01	0.005									
5 Protopterus		0.005		0.005	0.01	0.005									
6 Morm./Synodont		0.005		0.005	0.005	0.005									
7 Haplochr.Predat	0.15	0.002	0.001	0.001	0.001	0.001	0.05								
8 Haplochr.Phytop	0.15	0.003	0.004	0.002	0.001	0.001	0.1								
9 Haplochr.Benth	0.2	0.005	0.01	0.002	0.003	0.003	0.1								
10 R.argentea	0.5	0.15	0.1	0.1	0.05	0.05	0.6								
11 O.niloticus		0.1	0.05	0.04	0.025	0.04									
12 Other Tilapias		0.01	0.005	0.005	0.005	0.005									
13 Zooplankton			0.05	0.03	0.03	0.05	0.05	0.03	0.05	0.7	0.02	0.02	0.02	0.2	0.04
14 Lake prawn		0.4	0.5	0.2	0.15	0.05	0.05	0.05	0.15	0.05	0.03				0.01
15 Insects/Mollusc		0.05	0.25	0.5	0.65	0.7	0.05	0.02	0.7	0.05		0.03		0.05	0.05
16 Phytoplankton								0.5		0.2	0.7	0.45	0.95	0.1	0.05
17 Bent. Producers				0.01		0.02		0.25	0.05		0.1	0.3		0.2	0.35
18 Detritus				0.05	0.05	0.05		0.2	0.05		0.15	0.2	0.03	0.45	0.5
19 Import						0.01									

all three considerations) but instead considered five different scenarios which were all in general agreement with the current situation and concern of the Lake Victoria Fisheries Organization (M.Ntiba, pers. comm. to J.M.).

The settings for the two primary simulations are shown in Table 4 above. For the reasons discussed in the chapter by Cochrane (this volume), the weighting of 0.8 for ecological balance would probably have resulted in this consideration being largely over-ridden by the economic and social criteria. Therefore the primary differences in these two were the different weightings given to social value, and the values of jobs per unit of catch for each fishery. Running the open loop search routine with these two scenarios resulted in the following estimated fishing effort multipliers to achieve the goals as specified by the weightings assigned to economic and social value and

**Table 4:** Summary of the specifications defining the fishing policies considered for the Kenyan sector of Lake Victoria. Time period for each simulation : 15 years

a) Weights assigned	Scenario 1	Scenario 2
Total economic value	1	1
Social value (job opportunities)	0.5	1
Ecosystem stability	0.8	0.8

b) Relative no. of jobs per unit mass of catch.	Scenario 1	Scenario 2
Lates long line	21.5	
Large mesh nets	21.5	
Small mesh nets	1	0.5
Dagaa fisheries	2	1.5
Littoral lines	0.5	0.5

c) Relative weightings assigned to different species	Scenario 1	Scenario 2
Default value	1	
Nile perch, dagaa and Nile tilapias	1.2	
Haplochromines	1.5	

ecosystem stability. Results are expressed as multipliers of existing fishing mortality (e.g. to attain the goals reflected in Scenario 1, the effort in the Lates long line fishery would need to be increased to an estimated 2.8 times of the present effort level).

	Scenario 1	Scenario 2
Lates long lines	2.8	3.1
Large mesh sizes	2.4	2.3
Small mesh sizes	0.8	0.8
Dagaa fisheries	1.8	1.5
Littoral lines	1.2	1.4

These conclusions are consistent with what has been suggested and discussed with colleagues involved in Lake Victoria fisheries management (see various contributions in Cowx, 2001).

A third scenario was also examined, similar economic and social weightings as in Scenario 1 (Table 4), but with the additional goal of attempting to rebuild the populations of haplochromid species. The estimated pattern of fishing effort to achieve this goal was :

Lates longlines	0.09
Large meshsizes	1.83
Small mesh sizes	1.23
Dagaa fisheries	0.33
Littoral lines	0.61

This strategy would involve shutting down the fishery for Lates, and it is not clear how this would contribute to rebuild the haplochromid population. This requires further exploration.

In the fourth scenario we gave the same input as in Scenario 1 for economic and social value, but set a default target biomass of 0 for all species with the exception of economically important species (0.2) and haplochromids (0.5).

The estimated fishing effort multipliers to achieve this goal were :

Lates longlines	0.29
Large meshsizes	2.83
Small mesh sizes	9.98
Dagaa fisheries	0.004
Littoral lines	0.29

This represents a particularly large increase in the small mesh fishery which would increase fishing mortality on juveniles and Nile tilapias.

Finally, the fifth scenario maintained the Scenario 1 parameters but increased the social value to 1 instead of 0.5 and set the default target biomass as 1, with the exception of the haplochromids (2) and selected important species (1.5).

Lates longlines	1.06
Large meshsizes	1.60
Small mesh sizes	1.5
Dagaa fisheries	0.
Littoral lines	0.98

#### *The closed loop strategy simulation*

The closed loop strategy simulation examines the impact of observation and implementation uncertainty on the performance of the management strategy. In our example, a clear oscillation pattern is displayed for most of the groups situated at the highest trophic levels, meaning that the strong predator/prey relationship between adult and juvenile Nile perch had indirect impacts on other components of the ecosystem.

#### **Discussion**

The open loop simulations suggested that a recovery of haplochromids could be stimulated by an appropriate fishing strategy.

The possible reasons for the oscillating and yet opposite behavior in the biomass trends and catch values of adult and the juvenile *Lates* under the closed loop simulations need to be investigated in detail. According to Walters *et al.* (1997) an increased density of adult *Lates* would first lead to a decrease of juvenile biomass simply by predation whereas, at a later stage, it would lead to a decrease in density of other predators and competitors. This would result in improving feeding conditions and a simultaneous decrease on the predation pressure for these juveniles. This could lead to the observed oscillatory behaviour.

Clearly the evolution of the ecosystem of Lake Victoria has been controlled by a top-down pattern during the early years of increasing importance of Nile Perch in the actual catch. The current situation may differ from the early period

due to changes in the water quality (eutrophication, depletion of oxygen in the deep layers). An alternative hypothesis is the lower trophic levels are driven largely by bottom-up effects, whereas a top-down effect is controlling the dynamics of the higher trophic levels (D. Pauly, *pers.comm.*).

The scenarios for implementing an open loop search for the optimum fisheries strategy rely on specified values to be specified of the total economical value of the fishery, its value in terms of total employment, and of the ecological goals. The social value requires specification of the relative employment value of each fishing gear, while the ecological goals require an indication of the target biomass for each functional group in the ecosystem. It should be noted that when this study was done, little was known by the authors on these values or on the ecological targets that would be preferred by the different interest groups in the fishery. Hence the figures and choices shown here should be regarded as tentative only.

#### **Conclusion**

Although it provides very useful features for simulating the trajectory of catch and biomass over time, Ecosim has some limits in its predictive power. In particular, it would be useful to be able to include the impact of changes in water quality, especially in terms of variations in primary production. This could be explored further using the forcing functions of Ecosim, which opens up a large field for further investigation.

#### **Acknowledgements**

The authors are extremely grateful to the participants of the FAO/UBC Fisheries Center Ecopath Workshop for fruitful discussions. The assistance and advice of Villy Christensen and Carl Walters have also to be gratefully acknowledged.

#### **References**

- Bundy A. and Pitcher, T.J. (1995) An analysis of species changes in Lake Victoria: did the Nile perch act alone? Pages 111-135 in Pitcher, T.J. and Hart, P.J.B. (eds) *The Impact of Species Changes in African Lakes*. Chapman and Hall, London. 601pp.
- Christensen V. and Pauly, D. (1992) ECOPATH II a software for balancing steady state ecosystem models and calculating network characteristics. *Ecological Modelling* 61: 169-185.
- Christensen V. and Pauly, D. (eds) (1993) *Trophic Models of Aquatic Ecosystems*. ICLARM Manila, Philippines. ICLARM Conference Proceedings, 26: 390 pp.
- Christensen V. and Pauly, D. (1996) Ecological Modelling for All. *NAGA, The ICLARM Quarterly* 19 (2), 25-26.
- Cox I. G. (ed.). 2000. *Proceedings of the International*

- Symposium & Workshop on Management and Ecology of Lake and Reservoir Fisheries, University of Hull, England. 10-14 April 2000. in press.
- Mkumbo O. C., Okaranon J., Getabu A., Muhoozi L., Othina A., Cowx I.G. and Tweddle, D. (2000) Analysis of exploitation patterns for Nile perch in Lake Victoria. In Cowx, I.G.(ed.) Proceedings of the International. Symposium & Workshop on Management and Ecology of Lake and Reservoir Fisheries, University of Hull, UK. in press.
- Moreau J., Ligtvoet, W. and Palomares, M.L.D. (1993) Trophic relationships in the fish community of Lake Victoria, Kenya, with emphasis on the impact of Nile perch (*Lates niloticus*). P144-152 In Christensen, V. and Pauly, D. (eds.) 1993 op. cit.
- Villanueva M.C. and J. Moreau (2000) Recent trends of evolution in Lake Victoria fisheries as assessed by Ecopath 4 (with Ecosim) software. In I. Cowx (Ed.) Lake and Reservoirs Fisheries Management. Publ. The University of Hull. UK.
- Njiru M., Othina N. and Cowx, I.G. (2000) Lake Victoria invasion by water hyacinth a blessing for Lake Victoria fisheries. In Cowx I. G. (ed.), Proceedings of the International. Symposium & Workshop on Management and Ecology of Lake and Reservoir Fisheries, University of Hull, England. 10-14 April 2000. in press.
- Ogari, J. and S. Dadzie 1988. The food of the Nile perch, *Lates niloticus* (L.), after the disappearance of the haplochromine cichlids in the Nyanza Gulf of Lake Victoria (Kenya). J. Fish Biol. 32: 571-577.
- Pitcher, T.J. and Bundy, A. (1995) Assessment of the Nile perch fishery in Lake Victoria. Pages 163-180 in Pitcher, T.J. and Hart, P.J.B. (eds) The Impact of Species Changes in African Lakes. Chapman and Hall, London. 601pp.
- Reynolds, J. E. and Greboval, D.F. (1995) Socio-economic effects of the evolution of Nile perch fisheries in Lake Victoria: a review. F.A.O. CIFA Technical Papers 17, 148 pp.
- Tweddle, D. and Cowx, I.G. (eds.) (1999) Lake Victoria Fisheries Research Project – Phase II. Proceedings of the International Workshop held at the Triangle Hotel, Jinja, Africa. 29 March to 1 April 1999.
- Walters C., Christensen V. and Pauly, D. (1997) Structuring dynamic models of exploited ecosystems from trophic mass balanced assessments. Reviews in Fish Biology and Fisheries 7: 139-172.
- Wandera S. B. and Wanink, J.H. (1995) Growth and Mortality of Dagaa (*Rastrineobola argentea*, Fam. Cyprinidae) in Lake Victoria. NAGA, The ICLARM Quarterly 18 (1): 42-45.
- Wanink J. H., Goodswaard P.C. and Berger, M.R. (1999) *Rastrineobola argentea*, a major resource in the ecosystem of Lake Victoria. Pages 295-309 in van Densen W. L. T. and Morris M. J. (eds) Fish and Fisheries of lakes and reservoirs in Southeast Asia and Africa. 432 pp.
- Wilson D. C., Medard M., Harris C.K., and Wiley, D.S. (1996) Potentials for comanagement of the Nile Perch Fishery-Lake Victoria, Tanzania. Proc. of the Voices from the Common Conference of the International Association for the study of common property, Berkeley CA. 5-8 June 1996.
-

## **Names and Addresses of Workshop Attendees**

---

Jackie Alder  
Edith Cowan University, Joondalup  
Western Australia  
j.alder@fisheries.ubc.ca

Francisco Arreguín-Sánchez  
Centro Interdisciplinario de Ciencias del Mar  
Playa El Conchalito s/n.  
La Paz Apdo. Postal 592  
Baja California Sur  
Mexico 23000  
farregui@ipn.mx

Kerim Aydin  
School of Aquatic and Fishery Sciences  
University of Washington  
Seattle  
USA  
kerim@fish.washington.edu

Alasdair Beattie  
Fisheries Centre  
2204 Main Mall  
University of British Columbia  
Vancouver  
Canada V6T 1Z4  
a.beattie@fisheries.ubc.ca

Eny Anggraini Buchary  
Fisheries Centre  
2204 Main Mall  
University of British Columbia  
Vancouver  
Canada V6T 1Z4  
e.buchary@fisheries.ubc.ca

Alida Bundy  
Bedford Institute of Oceanography  
PO Box 1006,  
Darmouth N.S. B2Y 4A2  
Canada  
BundyA@mar.dfo-mpo.gc.ca

Luis E. Calderón-Aguilera  
Centro de Investigación Científica y de Educación  
Superior de Ensenada.  
Km 107 carretera Tijuana – Ensenada,  
Ensenada,  
Baja California,  
Mexico 22800

Wai-Lung Cheung  
Department of Ecology and Biodiversity  
The University of Hong Kong  
PokFuLam Road  
Hong Kong  
wcheung@wwf.org.hk

Villy Christensen  
Fisheries Centre  
2204 Main Mall  
University of British Columbia  
Vancouver  
Canada V6T 1Z4  
v.christensen@fisheries.ubc.ca

Kevern Cochrane  
FAO  
Rome  
Italy  
Kevern.Cochrane@fao.org

Luis Orlando Duarte  
Department of Oceanography  
University of Concepción  
Casilla (P.O. Box) 160-C  
Concepción,  
Chile  
lduarte@udec.cl

Villarino Fernanda  
Instituto Nacional de  
Investigación y Desarrollo Pesquero.  
Paseo Victoria Ocampo N° 1. (7600)  
Mar del Plata  
Argentina  
mlasta@inidep.edu.ar

Katia Friere  
Fisheries Centre  
2204 Main Mall  
University of British Columbia  
Vancouver  
Canada V6T 1Z4  
k.friere@fisheries.ubc.ca

Beth Fulton  
CSIRO  
Hobart  
Australia  
beth.fulton@marine.csiro.au

Camilo B. García  
Universidad Nacional de Colombia /  
Instituto de Investigaciones Marinas y Costeras  
A.A. 1016 Santa Marta  
Colombia

Sylvie Guénette  
Fisheries Centre  
2204 Main Mall  
University of British Columbia  
Vancouver  
Canada V6T 1Z4  
s.guenette@fisheries.ubc.ca

Johanna Heymans  
Fisheries Centre  
2204 Main Mall  
University of British Columbia  
Vancouver  
Canada V6T 1Z4  
j.heymans@fisheries.ubc.ca

Subhat Nurhakim  
Research Institute for Marine Fisheries  
Ministry of Agriculture of the Republic of Indonesia  
Jakarta  
Indonesia  
kanlutmb@indosat.net.id

Edward Nsiku  
109-7341 19<sup>th</sup> Avenue  
Burnaby BC  
Canada V3N 1E3  
emnsiku@aol.com.

Steve Martell  
Fisheries Centre  
2204 Main Mall  
University of British Columbia  
Vancouver  
Canada V6T 1Z4  
s.martell@fisheries.ubc.ca

Steve Mackinson  
CEFAS  
Lowestoft  
United Kingdom  
s.mackinson@cefes.co.uk

Jacques Moreau  
Department of Inland Fisheries - I.N.P./E.N.S.A.T.  
B.P. 107 Auzeville Tolosane  
31 326 Castanet  
Tolosan  
France  
ching@flora.ensat.fr and  
moreau@ensat.fr

Thomas A. Okey  
Fisheries Centre  
2204 Main Mall  
University of British Columbia  
Vancouver  
Canada V6T 1Z4  
t.okey@fisheries.ubc.ca

Tony Pitcher  
Fisheries Centre  
2204 Main Mall  
University of British Columbia  
Vancouver  
Canada V6T 1Z4  
t.pitcher@fisheries.ubc.ca

Lynne J Shannon  
Marine and Coastal Management  
Private bag X2  
Rogge Bay 8012  
South Africa  
lshannon@mcm.wcape.gov.za  
Tony Smith  
CSIRO  
Hobart  
Australia  
Tony.Smith@marine.csiro.au

Carl Walters  
Fisheries Centre  
2204 Main Mall  
University of British Columbia  
Vancouver  
Canada V6T 1Z4  
c.walters@fisheries.ubc.ca

Tonny Wagey  
Dept. of Earth and Ocean Sciences  
University of British Columbia  
Vancouver  
Canada  
twagey@eos.ubc.ca

Marcelo Vasconcellos  
Fisheries Centre  
2204 Main Mall  
University of British Columbia  
Vancouver  
Canada V6T 1Z4  
m.vasconcellos@fisheries.ubc.ca

Reg Watson  
Fisheries Centre  
2204 Main Mall  
University of British Columbia  
Vancouver  
Canada V6T 1Z4  
r.watson@fisheries.ubc.ca

Dirk Zeller  
Fisheries Centre  
2204 Main Mall  
University of British Columbia  
Vancouver  
Canada V6T 1Z4  
d.zeller@fisheries.ubc.ca