

# DEUTSCHES ELEKTRONEN-SYNCHROTRON **DESY**

DESY 80/20  
March 1980

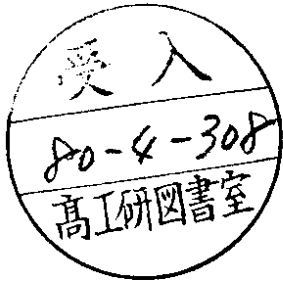

Y(9.46) DECAYS DO TEST QCD

by

T. F. Walsh

*Deutsches Elektronen-Synchrotron DESY, Hamburg*

P. M. Zerwas

*Institut für Theoretische Physik, TH Aachen*

NOTKESTRASSE 85 · 2 HAMBURG 52

To be sure that your preprints are promptly included in the  
**HIGH ENERGY PHYSICS INDEX** ,  
send them to the following address ( if possible by air mail ) :

**DESY**  
**Bibliothek**  
**Notkestrasse 85**  
**2 Hamburg 52**  
**Germany**

DESY 80/20  
March 1980

Y(9.46) DECAYS DO TEST QCD

by

T. F. Walsh

Deutsches Elektronensynchrotron DESY, Hamburg

and

P. M. Zerwas

Inst. f. Theor. Physik, TH Aachen

Abstract: QCD makes precise predictions for massive quarkonium decays,  $Q\bar{Q} \rightarrow 3G \rightarrow 3 \text{ jets}$ . The only experimental comparisons so far are for  $Y(9.46)$  decays to hadrons. However,  $Y(9.46)$  is not very massive, and 3-jet structure is hidden. Despite this we show that  $Y$  decays can be used to make firm statements about gluon color and spin. They form a nontrivial test of QCD. Simple alternative models with colorless or scalar gluons fail to explain the data.

Recent PETRA data on 3-jet production in  $e^+e^-$  annihilation /1/ provides strong support for quantum chromodynamics (QCD). However, it is an open question whether one really needs gluons with both a color charge and spin one to explain these 3-jet events. Presumably this evidence will soon be forthcoming. With this in mind, we re-examine the hadronic  $Y(9.46)$  decays. One can take two opposed views about this enterprise. One is to attempt to exclude "theories" without colored vector gluons mediating short distance reactions. The other view is that such "theories" are ugly or ill-defined, but are still useful for checking whether a given experimental result is really a nontrivial QCD test. The aim is to find features where big qualitative changes occur when the gluon's color charge and spin are altered. If this happens, the QCD test is convincing. (Ideally, one ought to examine such scenarios for every QCD test). One is then also insensitive to whether or not higher order radiative corrections in QCD are large (as they may be for quarkonium decays).

In this note we look to see how drastically QCD predictions for  $Y$  decays change on going to mock "theories" which either have colorless vector gluons or which have scalar gluons. The first point is new; the second is a generalization of existing observations /2/.

Gluon color charge. The argument is simple. In a colored gluon theory, the lowest nonvanishing contribution to hadronic quarkonium decay is  $Q\bar{Q} \rightarrow 3G$  (Fig.1A.). However, for vector gluons  $g(1^{--})$  without color the lowest order contribution is  $Q\bar{Q} \rightarrow g \rightarrow q\bar{q}$  (Fig.1B). (This is of course forbidden in QCD by color charge conservation since  $Q\bar{Q}$  is color neutral and the gluons in QCD color charged). The one-gluon-decay channel dominates the next order  $ggg$  contribution by two orders of magnitude,

$$\frac{\Gamma ( Q\bar{Q} \rightarrow g \rightarrow q\bar{q} )}{\Gamma ( Q\bar{Q} \rightarrow ggg )} = \frac{9\pi N_F}{4(\pi^2 - 9)\alpha_g}$$

We need the strong fine structure constant  $\alpha_g \sim 1/4$  to account for the 3-jet event rate at PETRA /3/. We also take the quarks in 3 colors and set  $N_F = 4$  flavors. Then the above ratio is  $O(100)$ .

As a consequence, in this colorless gluon theory  $Y$  decays to two back-to-back light  $q\bar{q}$  jets. The event topology on and off the  $Y$  resonance is the same. (The effect of the photon coupling to quark charge off resonance obviously does not alter this). Fig.2 compares thrust distributions on and off resonance /4/. A 2-jet decay of  $Y$  is clearly excluded. So is the colorless vector gluon theory. (Note that the 2-jet topology is only weakly affected by higher order corrections). On the other hand,  $Y$  decays to three gluon jets in QCD /5/. This decay mechanism does explain the data (solid curve in Fig.2.). The topology test is quite clean. It does not depend on the assumption that higher twist effects are unimportant, as is the case in lepton-nucleon tests of the gluon color charge. ( Here also, the colorless gluon theory differs dramatically from QCD /6/). Positive evidence for the gluons' color charge will come from the energy evolution of gluon jets /7/. Curiously, hadron spectra soften from  $J/\Psi$  to  $Y$  in the manner expected in QCD with colored nonabelian gluons /8/. (Of course, the  $J/\Psi$  is rather low in mass for this to be considered decisive).

Gluon spin. There is evidence that  $Y$  decays have a planar structure /9/,/\*/. The angular distribution of the normal to this plane is independent of the jet energies for a three-quantum state. (Final states with  $\geq 4$  quanta or low mass clusters would not account for the planarity). It is of the form  $d\sigma/d\cos\theta_N \propto 1 \pm \cos^2\theta_N$  for three  $J^P = 0^+$  particles and is  $1 - (1/3)\cos^2\theta_N$  for QCD /5/ ( $\theta_N$  being the angle between the normal to the plane and the  $e^+e^-$  beam axis).

One might think that the  $Q\bar{Q} \rightarrow 3G$  distributions predicted by QCD can be easily mimicked by any simple model with a three-body final state. This is not so, because of the symmetries of the 3-particle final states. For example,

$Q\bar{Q} \rightarrow 3S$  (three scalar gluons, colored to allow for  $J^{PC} = 1^{--}$ ) has a matrix element which must vanish at the center of the 3S Dalitz plot, as well as the midpoints of the three sides /11/. This is independent of any supposed higher order corrections, so long as the final state has three quanta (or three clusters which can be treated as approximately stable states). This already enforces a structure where one has two hard quanta and one softer one. The 3G distribution in QCD is, by contrast, rather close to 3-body phase space.

Koller and Krasemann /2/ have observed that in massless scalar gluon theories there is an additional dynamical enhancement of the configuration where one gluon has small momentum. This is simply due to the fact that for a massive quark  $Q$  at rest there is no angular momentum constraint against emission of a soft massless scalar particle. The matrix element for this soft emission is divergent as  $|\vec{p}| \rightarrow 0$  since the quark  $Q$  remains near its mass shell. Consequently, the most likely final state configuration is  $Q\bar{Q} \rightarrow S + S +$  soft  $S$ , giving effectively two jets. Spin then constrains the angular distribution of the thrust or sphericity axis to be  $d\sigma/d\cos\Theta \propto 1 - \cos^2\Theta$  (the angle  $\Theta$  measured relative to the beam axis). This conflicts with data /2/.

By contrast, a vector theory does not enhance  $Q\bar{Q} \rightarrow 2$  hard gluons + 1 soft gluon. This is because a quark spin must flip in emitting a soft transversely polarized vector gluon. The matrix element contains a recoil factor  $|\vec{p}|/m_Q$ , cancelling the divergence of the near-mass-shell quark propagator. The Dalitz plot density is therefore everywhere finite. The angular distribution of the thrust axis, averaged over all events, has been computed /12/ to be  $1 + 0.39 \cos^2\Theta$ . This is consistent with experiment /9/.

The lesson we wish to draw from these observations is that one cannot easily mimic the  $Y$  decay distributions without invoking essential elements of QCD: vector gluons with color charge. Despite the fact that 3-jet structure is hidden at  $Y$  energies, the agreement of data and QCD expectations is clearly nontrivial.

FOOTNOTE

/\*/ Quantitatively, the evidence for this appears about as significant as the evidence for the 2-jet structure in  $e^+e^-$  annihilation at SPEAR energies /10/.

REFERENCES

- /1/ R. Brandelik et al., Phys. Lett, 86B(1979) 243;  
D. P. Barber et al., Phys. Rev. Lett. 43(1979) 830;  
C. Berger et al., Phys. Lett 86B(1979) 418;  
W. Bartel et al., DESY 79/80.
- /2/ K. Koller and H. Krasemann, Phys. Lett. 88B(1979) 119.
- /3/ D. P. Barber et al., Phys. Lett, 89B(1979) 139;  
A. Ali et al., DESY 79/86;  
W. Bartel et al., DESY 79/80.
- /4/ S. Brandt, PLUTO collaboration, DESY 79/43.
- /5/ K. Koller and T. F. Walsh, Nucl. Phys. B140(1978) 449.
- /6/ M. Glück and E. Reya, DESY 79/13.
- /7/ K. Koller, T. F. Walsh and P. M. Zerwas, Phys. Lett. 82B (1979) 263.
- /8/ H. Meyer, PLUTO collaboration, DESY 79/81.
- /9/ C. Berger et al., Phys. Lett 82B (1979) 449.
- /10/ G. Hanson et al., Phys. Rev. Lett, 35 (1975) 1609.
- /11/ M. L. Stevenson et al., Phys. Rev. 125 (1962) 687.
- /12/ K. Koller, H. Krasemann and T. F. Walsh, Z. Physik C1 (1979) 71.

FIGURE CAPTIONS

- Fig.1. Dominant decay mechanisms of a heavy quarkonium  $1^{--} Q\bar{Q}$  resonance:  
(A) in QCD with colored vector gluons  $G$ ; (B) in an abelian theory with a colorless vector gluon  $g$  ( $q\bar{q}$  is a light quark pair).
- Fig.2. Thrust distributions off and on the  $Y(9.46)$  resonance. Data from Ref./4/. The significant difference between the distributions rules out colorless vector gluons. The resonance data are consistent with a 3-jet decay of  $Y$  (Ref./4/).



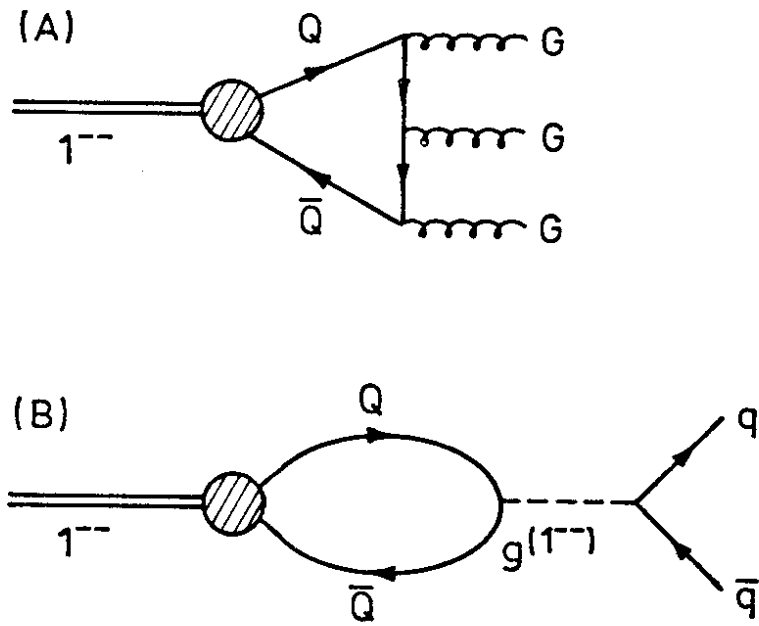

Fig.1

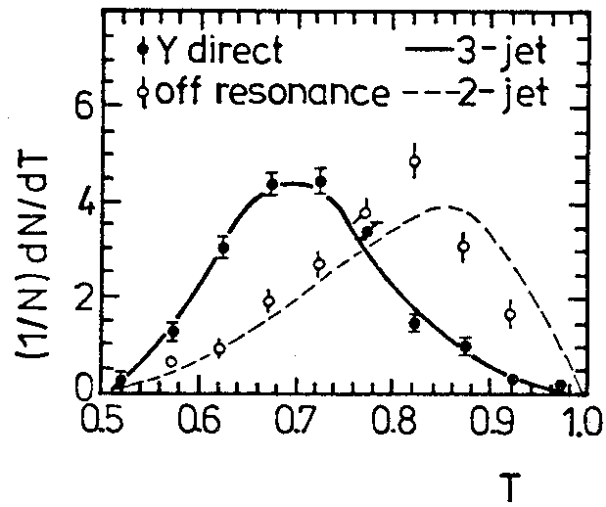

Fig. 2