

DESY 78/69  
November 1978



SUFFICIENT CONDITION FOR CONFINEMENT OF STATIC QUARKS

BY A VORTEX CONDENSATION MECHANISM

by

G. Mack and V. B. Petkova

*II. Institut für Theoretische Physik der Universität Hamburg*

NOTKESTRASSE 85 · 2 HAMBURG 52

To be sure that your preprints are promptly included in the  
**HIGH ENERGY PHYSICS INDEX** ,  
send them to the following address ( if possible by air mail ) :

**DESY  
Bibliothek  
Notkestrasse 85  
2 Hamburg 52  
Germany**

Sufficient condition for confinement of static quarks  
by a vortex condensation mechanism<sup>+</sup>

G.Mack and V.B.Petkova<sup>++</sup>

II. Institut für Theoretische Physik der Universität Hamburg

Abstract: We derive a sufficient condition for confinement of static quarks by a vortex condensation mechanism. It admits vortices that are thick at all times at the cost of constraining them to a finite volume  $\Lambda_i$  whose complement is not simply connected. The confining potential  $V(L)$  is estimated in terms of the change of free energy of a system enclosed in  $\Lambda_i$  which is induced by a change in vorticity (= singular gauge transformation applied to boundary conditions on  $\partial\Lambda_i$ .) For Abelian gauge theories in 3 dimensions the confining Coulomb potential is reproduced as a lower bound.

+ Work supported by Deutsche Forschungsgemeinschaft.

++ permanent address: Institute of Nuclear Research and Nuclear Energy, Bulgarian Academy of Sciences, Sofia, Bulgaria.

1 Introduction and summary of results.

In the work of Migdal, Polyakov, Kadanoff, t'Hooft and others [1,2] on the quark confinement problem, the idea is prevalent that one should try to generalize mechanisms which prevent spontaneous symmetry breaking in ferromagnets with a continuous global symmetry group  $G$  to Euclidean gauge field theories. In particular, t'Hooft [2] has emphasized that natural analogues of Bloch walls in ferromagnets exist in Yang Mills theories with a gauge group  $G$  that has a nontrivial center  $\Gamma$ . They are sometimes called vortices.

In ferromagnets, spontaneous magnetization breaks down when Bloch walls of large extension become sufficiently abundant. Absence of spontaneous magnetization leads to falloff of the 2-point spin correlation function with distance. The simplest Bloch walls appear in two dimensional Ising ferromagnets with spins  $\sigma[x] = \pm 1 \in \mathbb{Z}_2$ . They are called Peierls countours there. The spin direction changes from  $+1$  to  $-1$  when one crosses the countour. [In formulae: let  $b$  be a link in a lattice; its boundary  $\dot{b} = \partial b$  consists of two points  $x, y$ . Define  $\sigma[\dot{b}] = \sigma[x]\sigma[y]^{-1}$ . Then  $\sigma[\dot{b}] = -1$  when a Peierls countour passes through the link  $b$ .] These Bloch walls have a thickness of only one lattice spacing. However, in ferromagnets with continuous symmetry group, thick Bloch walls can also appear in which the spin direction rotates very gently as one crosses from one side to the other. These thick Bloch walls can be made responsible for absence of spontaneous symmetry breakdown in 2-dimensional ferromagnets with continuous symmetry group at low temperatures [4,5].

We consider lattice gauge theories without charged fields. The place of spins is taken by (random) variables  $U[b] \in G$  assigned to links  $b$  in the lattice. For a closed path  $C$  consisting of links  $b_1 \dots b_n$  one defines the parallel transporter  $U[C]$  around  $C$  by

$$U[C] = U[b_n] \dots U[b_1] \tag{1.1}$$

In particular, the boundary  $\dot{p} = \partial p$  of a plaquette (2 dimensional unit cell) consists of four links  $b_1 \dots b_4$ , and

$$U[\dot{p}] = U[b_4] \dots U[b_1]$$

The place of two point spin correlation functions is taken by the expectation value of the "Wilson loop integral". Let  $\mathcal{D}$  be a unitary representation of the gauge group  $G$  and  $\chi$  its character,  $\chi(U) = \text{tr } \mathcal{D}(U)$ . Consider a closed path which bounds a rectangular surface of  $L \times T$  plaquettes. Suppose that

$$|\langle \chi(U[C]) \rangle| \leq c \cdot e^{-TV(L)} \quad \text{for } T \gg L. \quad (1.2)$$

$c$  is a constant. According to Wilson [6], static quarks will then be confined by a potential  $\approx V(L)$  if they transform according to the representation  $\mathcal{D}$  of  $G$  and if

$$V(L) \rightarrow \infty \quad \text{as } L \rightarrow \infty \quad (1.3)$$

In nonabelian gauge theories one hopes for an approximately linear rise of  $V(L)$  with  $L$ . We will consider theories in  $\nu = 3$  and 4 dimensions.

Vortices can (in principle) produce a falloff of  $\langle \chi(U[C]) \rangle$  with  $L$  much as Bloch walls can produce a falloff of spin correlation functions in ferromagnets [3,7]. The simplest vortices have a thickness of only one lattice spacing. Their position is specified by a set  $S$  of plaquettes which is  $\text{co}$ -closed, i.e. they form a closed path ( $\nu = 3$ ) resp. closed 2-dimensional surface ( $\nu = 4$ ) on the dual lattice. Such a path resp. surface can wind around the Wilson loop  $C$ . Preliminarily, the reader may imagine (following Yoneya [7]) that a vortex on  $S$  is characterized by  $U[\dot{p}] \approx \gamma$  for  $p \in S$ ,  $\gamma$  a nontrivial element of  $\Gamma$ . ( $\gamma = -1$  if  $\Gamma = \mathbb{Z}_2$ ). The results of ref. [8] for an  $SU(2)$  model show that such thin vortices can confine static quarks for sufficiently large coupling constants  $\beta^{-1}$  (i.e. at high temperatures when Euclidean QFT is considered as a classical statistical mechanics), but that they are insufficient to do the same at small  $\beta^{-1}$  (when the center  $\Gamma$  of  $G$  is discrete. For abelian groups  $G$  the situation is somewhat different, cp. below). It was concluded that thick vortices should be allowed for. In a thick vortex it can happen that  $U[\dot{p}] \approx 1$  for all plaquettes.

In this paper we derive a sufficient condition for confinement of static quarks. It is applicable for arbitrary compact gauge group  $G$  with nontrivial center  $\Gamma$ , hence in particular for  $G = SU(N)$ ,  $\Gamma = \mathbb{Z}_N$ ,  $N = 2, 3, \dots$ . [Among the simply connected compact simple Lie groups, only  $G_2$ ,  $F_4$  and  $E_8$  have trivial center]. Our condition is similar in spirit to t'Hooft's conjecture [2] but there are also essential differences. We admit vortices which are thick at all times, at the cost of restricting them to a finite volume in space time. A mass gap is not required, instead the result is stated in terms of dependence on boundary conditions. We work on a lattice, but at a formal level our considerations and results (of Sect. 2) carry over to theories on continuous space time.

To be specific we take the Euclidean action to be of the form

$$L(U) = \beta \sum_p \mathcal{L}(U[p]) \quad (1.4a)$$

The function  $\mathcal{L}$  on  $G$  is supposed to be real, bounded above, gauge invariant in the sense that  $\mathcal{L}(V V_1 V^{-1}) = \mathcal{L}(V_1)$ , and it must satisfy  $\mathcal{L}(V) = \mathcal{L}(V^{-1})$ , for  $V, V_1 \in G$ . Summation is over all plaquettes  $p$  in the lattice  $\Lambda$ . The path measure is

$$d\mu(U) = \frac{1}{Z} \prod_{b \in \Lambda} dU[b] e^{L(U)}. \quad (1.4b)$$

$dU[b]$  is normalized Haar measure on  $G$  and product over  $b$  runs over all links on the lattice. Our results remain valid for the modified  $SU(2)$ -models studied in ref. [8] (since their path measure also has the Markov property). The proof is the same.

To begin with, we should say what a "vortex" is. However we shall see that it is not necessary to specify that. Instead it suffices to say what is meant by a "change of vorticity".

Change of vorticity will be labelled by an element  $\gamma$  of the center  $\Gamma$  of the gauge group  $G$ . If  $G$  is abelian,  $\Gamma = G$ . If  $G$  is a (simply connected) <sup>compact</sup> semisimple Lie group then  $\Gamma$  is a finite group. In any case we write  $d\gamma$  for normalized Haar measure on  $\Gamma$ .

We will need some topology.

We consider finite lattices  $\Lambda \subset \mathbb{Z}^\nu$  as cell complexes made of (oriented) 0-cells, 1-cells, ...  $\nu$ -cells. 0-cells are points, 1-cells are links, 2-cells are plaquettes, 3-cells are 3-dimensional unit cubes (cubes for short) etc..  $n$ -cells are open subsets of  $\mathbb{R}^\nu$ , but  $\Lambda$  is assumed closed, i.e. it contains with every cell also the cells on its boundary. In this way,  $\Lambda$  specifies a subset of  $\mathbb{R}^\nu$  (in the case of free boundary conditions. For cyclic boundary conditions some points on the boundary are identified). Thereby  $\Lambda$  inherits a topology and it makes sense to say that  $\Lambda$  is simply connected, or not. We write  $\partial$  for the boundary operator, and  $p \in \partial c$  if  $p$  has incidence number +1 with the boundary of  $c$ , etc.. It is convenient to use also the co-boundary operator  $\hat{\partial}$ . For cells it is defined by

$$c \in \hat{\partial} p \quad \text{if and only if} \quad p \in \partial c, \text{ etc.}$$

$\hat{\partial}$  is the boundary operator on the dual lattice. One says that  $S$  is closed if  $\partial S = 0$  (empty), coclosed (= closed in the dual lattice) if  $\hat{\partial} S = 0$ .

We consider sublattices  $\Lambda_i$  of one big lattice  $\Lambda$  whose complement in  $\Lambda$  is not simply connected.<sup>+</sup> They will be called vortex containers. They are supposed to wind around  $C$ , i.e.  $C$  cannot be shrunk to a point in the complement of  $\Lambda_i$  in  $\Lambda$ . Different vortex containers may touch but not intersect each other or the path  $C$ . A vortex container in 3 dimensions (4 dimensions) is shown in Fig. 1a (Figs. 1a, b, c). It can be viewed as a 3-dimensional (4-dimensional) neighborhood of a path (2-dimensional surface) winding around  $C$ .  $\Lambda_i$  are considered as closed  $\nu$ -dimensional cell complexes.

Let  $\partial\Lambda_i$  be the boundary of  $\Lambda_i$ . It is a  $\nu-1 = 2$  (3) dimensional cell complex. We consider the gauge theory on  $\Lambda_i$  which is specified by the path measure (1.4) plus boundary conditions  $u$  on  $\partial\Lambda_i$ . The boundary conditions prescribe  $u[b]$  for all links  $b \in \partial\Lambda_i$ .

A change of vorticity in  $\Lambda_i$  is a change of boundary conditions  $u \rightarrow u_\gamma$  on  $\partial\Lambda_i$  which has the form of a "singular gauge transformation":

[Only equivalence classes of singular gauge transformations modulo ordinary gauge transformations are relevant. Importance of singular gauge transformations was emphasized by Ezawa [9] and Englert [10]; see also [11]]. It may be chosen as follows. Let  $P_i$  be a set of links in  $\partial\Lambda_i$  which is co-closed in

<sup>+</sup> In the main text, vortex containers etc. will be labelled by an index pair  $i, r$  which indicates their position.

$\partial\Lambda_i$  and winds around  $C$  as shown in Figs.1. A change of vorticity (in  $\Lambda_i$ ) by  $\gamma \in \Gamma$  is effected by mapping

$$U[b] \rightarrow U_\gamma[b] = \begin{cases} U[b]^\gamma & \text{if } b \in \mathcal{P}_i \\ U[b] & \text{otherwise} \end{cases} \quad (1.5)$$

This does not change  $U[\dot{p}]$  for plaquettes  $p \in \partial\Lambda_i$ , but there does not exist  $V[x] \in G$  which is defined for all vertices  $x \in \partial\Lambda_i$  and such that  $U_\gamma[b] = V[x]U[b]V[x]^{-1}$  for all links  $b = (x,y) \in \partial\Lambda_i$ .

Example: Gauge inequivalent "Classical vacua" = (configurations  $U$  with  $U[\dot{p}] = 1$  for all  $p \in \partial\Lambda_i$ ) are mapped into each other by map (1.5).

Let  $Z(\Lambda_i, U)$  be the partition function of the system in  $\Lambda_i$  with boundary conditions  $U$ . A change of vorticity produces a change  $\mu(\gamma)_{\Lambda_i, U}$  in free energy

$$\beta\mu(\gamma)_{\Lambda_i, U} \equiv -\ln \left\{ Z(\Lambda_i, U_\gamma) / Z(\Lambda_i, U) \right\} \quad (1.6)$$

Our results are simplest to state for gauge group  $G = SU(2)$  with center  $\Gamma = \mathbb{Z}_2$ . The general result is embodied in Eq. (2.19) of Sect.2. For  $G = SU(2)$ ,  $\Gamma$  has only one nontrivial element  $\gamma = -1$ . Quarks transform nontrivially under  $\Gamma$ .

Let

$$\xi_i = \max_U \beta\mu(-1)_{\Lambda_i, U} \quad (1.6a)$$

Then inequality (1.2) for the expectation value of the Wilson loop integral is fulfilled for

$$V(L) = -\frac{1}{T} \sum_i \ln \tanh \frac{1}{2} \xi_i \quad (1.7)$$

Summation is over all the vortex containers that can be fitted around the loop  $C$ .  $0 \leq \xi_i < \infty$  always since  $\mu(\gamma)_{\Lambda_i, U_\gamma} = -\mu(\gamma)_{\Lambda_i, U}$  for  $\gamma = -1$  by definition; the maximum in (1.6a) exists since the space  $G \times \dots \times G$  of all boundary conditions is compact. Because of translation invariance, arrangement of vortex containers can always be made in such a way that the r.h.s. of (1.7) becomes  $T$ -independent for large  $T$ . ( $L \cdot T$  is the area enclosed by  $C$ ;  $T \gg L$ ). A possible arrangement of vortex containers is shown in Fig.2.

Requirement (1.3) will be fulfilled, and static quarks will



be confined, if an arrangement of vortex containers can be found such that the sum on the r.h.s. of (1.7) diverges to infinity.

Suppose for instance that we insist on choosing our vortex containers in such a way that for some constant  $\xi$  ( $0 < \xi < \infty$ )

$$\beta\mu(-1)_{\Lambda_i, U} < \xi \quad (1.8)$$

for all boundary conditions  $U$  and all containers  $\Lambda_i$ . Let  $\tau N(L)$  be the number of <sup>such</sup> vortex containers that can be fitted around  $C$  for  $\tau \gg L$ . Then  $V(L) \rightarrow \infty$  for  $L \rightarrow \infty$  if  $N(L) \rightarrow \infty$ . [In particular, if  $\tau N(L) \propto \tau L$ , the area enclosed by  $C$ , one would get a linearly rising potential  $V(L)$ ].

The change  $\mu$  in free energy can also be reexpressed in terms of a ratio of expectation values of an operator  $\mathcal{B}_\gamma[S]$  for different boundary conditions

$$\beta\mu(\gamma)_{\Lambda_i, U} = \frac{1}{2} \ln \frac{\langle \mathcal{B}_\gamma[S] \rangle_{\Lambda_i, U_\gamma}}{\langle \mathcal{B}_\gamma[S] \rangle_{\Lambda_i, U}} \quad \text{for } \gamma = -1 \in \mathbb{Z}_2. \quad (1.9)$$

$S$  consists of a coclosed set of plaquettes  $p$  inside  $\Lambda_i$  which winds around the path  $C$  like  $\Lambda_i$  itself. Otherwise  $S$  is arbitrary and  $\langle \mathcal{B}_\gamma[S] \rangle$  does not actually depend on  $S$  so long as  $S$  winds around  $C$  once. The expectation value

$$\langle \mathcal{B}_\gamma[S] \rangle_{\Lambda_i, U} \equiv \left\langle \prod_{p \in S} \exp \beta \{ \mathcal{L}(U[p]_\gamma) - \mathcal{L}(U[p]) \} \right\rangle \quad (1.10)$$

$\langle \rangle_{\Lambda_i, U}$  is the expectation value for the system in  $\Lambda_i$  with boundary conditions  $U$  on  $\partial\Lambda_i$ .

In Sect. 3 of this paper we will apply our general result (2.19) to an abelian gauge theory in 3 space time dimensions. In abelian theories  $\Gamma = G$  and the parameter  $\gamma \in \Gamma$  in (1.5) may take values close to 1 if  $G$  is continuous. As a result, the effect of thin vortices does not become negligible for large  $\beta$ , since the change  $\mu$  of free energy always tends to zero when  $\gamma \rightarrow 1$ . Put another way, one may compose thick vortices with any  $\gamma$  from thin vortices with  $\gamma \approx 1$ . Upon inserting some elementary estimates for thin vortices, inequality (2.19) reproduces the confining

Coulomb potential  $V(L) \gg c(\beta) \ln L$  as a lower bound. For large  $\beta$ ,  $c(\beta) \sim \text{const} \cdot \beta^{-1}$ . For a special choice of Lagrangean this result has been derived before in ref. [12] by another method. Our treatment amounts to generalizing the technique of Dobrushin and Shlosman's for 2-dimensional ferromagnets.

We conclude with some comments and speculations on the possible uses of our result (1.7). The vortex containers  $\Lambda_i$  have a certain length (area) given by the minimal number  $|P_i|$  of links in  $P_i$ , and a certain width  $d_i$ . The distance of  $S$  from the boundary  $\partial\Lambda_i$  can be chosen to be  $\approx d_i/2$  in (1.9). [One may have different widths in different directions. For a moment let us imagine that they are all equal and call  $d_i$  the diameter of  $\Lambda_i$ ]. We are ready to accept the possibility that the change of free energy  $\mu$  as defined by Eq. (1.6) comes out proportional to the length (surface)  $|P_i|$  of the vortex container, for fixed diameter  $d_i$ . Suppose one could show that the effect of the boundary conditions in (1.9) decreases like  $e^{-md_i/2}$  with the diameter  $d_i$  of the vortex container, so that  $\max \mu \leq \text{const} \cdot |P_i| e^{-md_i/2}$ , and condition (1.8) is satisfied for  $d_i \gg \frac{2}{m} \ln |P_i|$  ( $m$  is some mass). Then Eq. (1.7) produces a confining potential  $V(L) \gg \text{const} \cdot L (\ln L)^2$  which rises approximately linearly. A possible mechanism for producing a mass gap in nonabelian gauge theories was suggested in refs. [13, 14].

One could also attempt computing the relevant partition functions in a vacuum tunneling approximation [15], using transfer matrices that increase the diameter  $d_i$  of the vortex container by one unit step by step, and wave functions depending on variables  $U[b]$  attached to links  $b$  in the boundaries of the growing vortex container. We are not prepared to discuss any approximation schemes in this paper, but we note that the treatment of the abelian model shows some similarity with a vacuum tunneling approach (except that it produces a rigorous bound instead of an approximation).

## 2. Sufficient condition for confinement of static quarks

We consider a theory described by the action (1.4a). The factor  $\beta$  will be absorbed into  $\mathcal{L}$  in this section.

We will study the expectation value  $\langle \chi(u[C]) \rangle$  of the "Wilson loop integral" for characters  $\chi$  that are nontrivial on  $\Gamma$ .

$$\chi(V\gamma) = \chi(V)\omega_0(\gamma) \quad \text{for } V \in G, \gamma \in \Gamma, \quad (2.1)$$

with  $\omega_0$  a nontrivial (1-dimensional) representation of  $\Gamma$ .

We start from the path integral formula for  $\langle \chi(u[C]) \rangle$ . We will rewrite it in another equivalent form, Eq. (2.16) below, by applying a series of variable transformations. In these variable transformations, invariance of the Haar measure on  $G$  is used repeatedly

$$dU = dU_1 U_2 = dU_1 dU_2 \quad \text{for all } U_i \in G.$$

Haar measure  $d\gamma$  on  $\Gamma$  has similar invariance properties. Our results will follow from Eq. (2.16) as a consequence of elementary inequalities.

Our theory lives on a  $\nu$ -dimensional hypercubic lattice  $\Lambda \subset \mathbb{Z}^\nu$ , ( $\nu = 3, 4$ ).

We will regard the  $x^1$ -axis as (Euclidean) time direction. We write  $e_1$  for the unit vector in time direction.

Let  $C$  be a rectangular path in the  $x^1 x^2$ -plane as shown in Fig. 3.

It encloses the area  $\Xi$  consisting of points

$$\Xi = \left\{ x = (x^1, x^2, 0 \dots 0) ; 0 < x^1 < T, 0 < x^2 < L \right\}$$

We divide our lattice into hyperplanes  $x^1 = \text{integer}$ , and open layers  $\Sigma^r = \left\{ x, r - \frac{1}{2} < x^1 < r + \frac{1}{2} \right\}$  between them,  $r = \pm \frac{1}{2}, \pm \frac{3}{2}, \dots$ . Links  $b \in \Sigma^r$  point in the time direction,  $b = (x, x + e_1)$ . For such  $b$  we introduce

$$\|b\| = \max_{\mu=2 \dots \nu} |x^\mu| \quad (2.2)$$

(distance to the time axis). We restrict attention to layers  $\Sigma^r$  which intersect the path  $C$ , viz.  $0 < r < T$ . One of them is indicated in Fig. 3.

To each  $r$  let us fix an increasing sequence of integers  $a_i^r$ ;  $i = 0 \dots s_r, \geq 0$  with  $a_0^r = 0$ . Let

$$\tilde{S}_i^r = \{ b \in \Sigma^r, \|b\| = a_i^r \}, \quad i = 0, 1, \dots, s_r. \quad (2.3)$$

$\tilde{S}_0^r$  is a single link on the path  $C$ . Some of the layers may contain none of the sets  $\tilde{S}_i^r$  with  $i \geq 1$ .

Every set  $\tilde{S}_i^r$  of links specifies a set  $S_i^r$  of plaquettes as follows. Plaquette  $p \in \Sigma^r$  is in  $S_i^r$  if it contains a link  $b \in \tilde{S}_i^r$  in its boundary, and the other timelike link  $b \in \partial p$  has  $\|b\| = a_{i+1}^r$  (cp. Fig. 4). If plaquettes  $p$  are considered as elements of the dual lattice,  $S_i^r$  form closed paths resp. surfaces winding around  $C$ .

Finally we choose vortex containers  $\Lambda_i^r$  as sublattices = closed  $\nu$ -dimensional sub-cell complexes of  $\Lambda$  such that

$$\Lambda_i^r \supset S_i^r \quad (i = 1 \dots s_r) \quad (2.4)$$

They are not allowed to intersect each other or the path  $C$  except possibly with their boundaries (i.e. they are allowed to touch). They wind around the path  $C$ . A possible arrangement is shown in Fig. 2. The boundary  $\partial \Lambda_i^r$  of  $\Lambda_i^r$  will be considered as a  $\nu-1$  dimensional cell complex so that it contains 0-cells, 1-cells = links, ...  $(\nu-1)$ -cells = plaquettes resp. cubes.

Special case: A thin vortex container is obtained if we take the smallest  $\nu$ -dimensional cell complex  $\Lambda_i^r$  which contains  $S_i^r$ .

It is convenient to introduce some further subsets of  $\Sigma^r$ .

$$\mathbb{F}_i^r = \{ b \in \Sigma^r, a_{i-1}^r \leq \|b\| < a_i^r \}, \quad i = 1, 2, \dots, s_r.$$

$$\mathbb{F}_{s_r+1}^r = \{ b \in \Sigma^r; a_{s_r}^r \leq \|b\| \} \quad (2.5)$$

$\mathbb{F}_i^r$  consists of timelike links "between"  $\tilde{S}_{i-1}^r$  and  $\tilde{S}_i^r$ ; it includes  $\tilde{S}_{i-1}^r$  but not  $\tilde{S}_i^r$  (see Fig. 5). The intersection of the boundary  $\partial \Lambda_i^r$  of the vortex container with the open layer  $\Sigma^r$

decomposes into two disjoint pieces, each of them winding around  $C$ . They contain sets of links

$$\begin{aligned} P_i^r &= \{ b \in \Sigma^r \cap \partial \Lambda_i^r ; \|b\| < a_i^r \} \\ P_i^{r'} &= \{ \text{as above} ; \|b\| > a_i^r \} \end{aligned} \quad ; \quad i=1,2,\dots,s_r \quad (2.6)$$

$P_i^r$  is like  $\tilde{\Sigma}_i^r$ , except that it consists of links in the boundary of  $\Lambda_i^r$  (rather than in its interior).

Let us now return to the Wilson loop. Its expectation value is given by

$$\langle \chi(u[C]) \rangle = \frac{1}{Z} \int \prod_b dU[b] \chi(u[C]) \exp \sum_p \mathcal{L}(u[p]) \quad (2.7)$$

Here and everywhere, sums and products over  $b, p$  without further specification run over all links resp. plaquettes of the total lattice  $\Lambda$ .

Let  $\Lambda^c$  be the closure of the complement of all the vortex containers  $\Lambda_i^r$  in  $\Lambda$ .  $\Lambda^c$  is again a cell complex and  $\Lambda^c \cap \Lambda_i^r = \partial \Lambda_i^r$ .

We divide the variables  $U[b]$  into those associated with links in one of the vortex containers, and those in  $\Lambda^c$ . The former ones will be renamed  $U'[b]$ , the latter ones  $U_1[b]$ . Since  $b \in \partial \Lambda_i^r$  are in both sets,  $\delta$ -functions will appear. ( $\delta(u)$  is defined by  $\int du f(u) \delta(u) = f(1)$ ). Thus

$$\begin{aligned} \langle \chi(u[C]) \rangle &= \frac{1}{Z} \int \prod_{b \in \Lambda^c} dU_1[b] \chi(u_1[C]) \exp \sum_{p \in \Lambda^c} \mathcal{L}(u_1[p]) \cdot \\ &\quad \cdot \prod_{r,i} \left\{ \int \prod_{b \in \Lambda_i^r} dU'[b] \exp \sum_{p \in \Lambda_i^r} \mathcal{L}(u'[p]) \cdot \prod_{b \in \partial \Lambda_i^r} \delta(u_1[b] u'[b]) \right\}. \end{aligned} \quad (2.9)$$

Here and in the following, the prime ' on  $\Sigma'$  means that plaquettes in the boundary  $\partial \Lambda_i^r$  are omitted.

Since the path  $C$  does not intersect any of the vortex containers,  $\chi(\cdot)$  involves only  $U_1$ -variables.

Given elements  $y_i^r \in \Gamma$  of the center of the gauge group ( $i=1, \dots, s_r$ ) we make a variable substitution as follows

$$u_1[b] = \begin{cases} u[b] y_i^r & \text{if } b \in \mathbb{F}_i^r \\ u[b] & \text{if } b \notin \cup \mathbb{F}_i^r \end{cases} \quad (2.10)$$

The path  $C$  has one link in  $\mathbb{F}_1^r$  for each  $r$ ; all other links in  $C$  are outside  $\cup \mathbb{F}_i^r$ . Therefore

$$\chi(u_1[C]) = \chi(u[C]) \omega_0(\prod_r y_i^r)$$

We may integrate (sum) the  $y_i^r$  over  $\Gamma$ , using normalized Haar measure  $dy$  on  $\Gamma$ . As a result

$$\begin{aligned} \langle \chi(u[C]) \rangle &= \frac{1}{Z} \int \prod_{b \in \Lambda^c} du[b] \chi(u[C]) & (2.11) \\ &\int \prod_{r,i} dy_i^r \omega_0(\prod_r y_i^r) \exp \sum_{p \in \Lambda^c} \mathcal{L}(u[p]) \\ &\prod_{r,i} \left\{ \int \prod_{b \in \Lambda_i^r} du'[b] \exp \sum_{p \in \Lambda_i^r} \mathcal{L}(u'[p]) \prod_{b \in \partial \Lambda_i^r} \delta(u_1[b] u'[b]^{-1}) \right\} \end{aligned}$$

In writing the first  $\exp \sum \mathcal{L}$  as a function of  $u[p]$  rather than  $u_1[p]$  we used the fact that

$$u[p] = u_1[p] \quad \text{for } p \in \Lambda^c$$

This is so because the boundary  $\dot{p}$  of any plaquette  $p \in \Lambda^c$  contains either none or two links in anyone of the sets  $\mathbb{F}_i^r$ . If there are two, they have opposite direction. Since  $y_i^r$  are in the center  $\Gamma$  of  $G$  they cancel out.

Next we inspect the inner integral. Let  $\Lambda'$  be some sublattice of  $\Lambda$ , i.e. a closed  $\nu$ -dimensional cell complex. We define the partition-function of the system in  $\Lambda'$  with boundary conditions  $U$ . That is, the string bit variables take prescribed values  $U[b]$  for all links  $b \in \partial \Lambda'$ .

$$Z(\Lambda', u) = \int \prod_{b \in \Lambda'} dU'[b] \exp \sum_{p \in \Lambda'} \mathcal{L}(U'[p]) \prod_{b \in \partial \Lambda'} \delta(U[b] U'[b]^{-1}) \quad (2.12)$$

We note that it is invariant under the action of gauge transformations on the boundary conditions  $U$  : Let  $V[x] \in G$  be defined for all vertices (0-cells)  $x \in \partial \Lambda'$  and let  $U[b] \rightarrow V[x] U[b] V[y]^{-1}$  for  $b = (x, y) \in \partial \Lambda'$ . Then  $Z(\Lambda', u)$  remains unchanged. To see this, extend the definition of  $V$  to the interior of  $\Lambda'$  by setting  $V[x] = 1$  for all  $x \notin \partial \Lambda'$ , and perform a variable transformation  $U'[b] \rightarrow V[x] U'[b] V[y]^{-1}$  on the variables of integration.

Let us now consider one vortex container  $\Lambda_i^r$ . Let  $\sigma \in \Gamma$ . Given  $U$  on  $\partial \Lambda_i^r$  we define a configuration  $U_\sigma$  on the boundary  $\partial \Lambda_i^r$  by

$$U_\sigma[b] = \begin{cases} U[b] \sigma & \text{if } b \in P_i^r \\ U[b] & \text{otherwise} \end{cases} \quad (2.13)$$

The substitution  $U \rightarrow U_\sigma$  is a "singular gauge transformation" if  $\sigma \neq 1$ . Since any plaquette  $p \in \partial \Lambda_i^r$  has none or two links of opposite direction in  $P_i^r$ , it follows that  $U_\sigma[p] = U[p]$  for all plaquettes  $p \in \partial \Lambda_i^r$ . More generally, let  $A$  be any topologically trivial part of the surface  $\partial \Lambda_i^r$ . Then the substitution  $U \rightarrow U_\sigma$  agrees with the action of a gauge transformation  $V[x]$  on  $A$ . However it is not an ordinary gauge transformation;  $U_\sigma[b] \neq V[x] U[b] V[y]^{-1}$  for any  $V$  that is defined everywhere on  $\partial \Lambda_i^r$ .

The  $\delta$ -function in (2.9) involves variables  $U_1[b]$  for  $b \in \partial \Lambda_i^r$ . Since  $\partial \Lambda_i^r$  intersects  $F_i^r$  in  $P_i^r$  and  $F_{i+1}^r$  in  $P_i^{r'}$ , Eq. (2.10) specializes to

$$U_1[b] = \begin{cases} U[b] \gamma_i^r & \text{if } b \in P_i^r \\ U[b] \gamma_{i+1}^r & \text{if } b \in P_i^{r'} \\ U[b] & \text{otherwise} \end{cases} \quad (2.10')$$

We note that  $U_1[b]$  differs only by an ordinary gauge transformation from  $U_\sigma[b]$  as defined by Eq. (2.13), for  $\sigma = \gamma_i^r (\gamma_{i+1}^r)^{-1}$ . [Explicitly  $U_\sigma[b] = V[x] U_1[b] V[y]^{-1}$  for  $V[x] = \gamma_{i+1}^r$  if  $x \in \partial \Lambda_i^r$ ,  $x^1 > r$ ,

and  $V[x] = 1$  otherwise.] Consequently, the integral in  $\{\}$  in Eq. (2.11) is equal to a partition function  $Z(\Lambda_i^r, u_\sigma)$ ,  $\sigma = \gamma_i^r (\gamma_{i+1}^r)^{-1}$ ;  $Z$  is defined by Eq. (2.12).

We introduce new variables

$$\sigma_i^r = \gamma_i^r (\gamma_{i+1}^r)^{-1}; \quad i = 1 \dots s_r$$

with  $\gamma_{s_r+1}^r = 1$ . It follows that  $\gamma_1^r = \prod_{j=1}^{s_r} \sigma_j^r$ . Thus

$$\omega_o \left( \prod_r \gamma_1^r \right) = \omega_o \left( \prod_{r,i} \sigma_i^r \right) = \prod_{r,i} \omega_o(\sigma_i^r)$$

Because of invariance of Haar measure on  $\Gamma$ ,  $\prod dy_i^r = \prod d\sigma_i^r$ . Putting everything together into Eq. (2.11) we obtain

$$\begin{aligned} \langle \chi(u[c]) \rangle &= \frac{1}{Z} \int_{b \in \Lambda^c} \prod du[b] \chi(u[c]) \exp \sum_{p \in \Lambda^c} \mathcal{L}(u[p]) \\ &\quad \cdot \prod_{i,r} \left\{ \int d\sigma_i^r \omega_o(\sigma_i^r) Z(\Lambda_i^r, u_{\sigma_i^r}) \right\} \end{aligned} \quad (2.14)$$

It is convenient to introduce normalized probability distributions  $p(\gamma)$  on  $\Gamma$  by

$$P_{\Lambda_i^r, u}(\gamma) = Z(\Lambda_i^r, u_\gamma) / \int_{\Gamma} d\sigma Z(\Lambda_i^r, u_\sigma) \quad (2.15)$$

This gives finally

$$\begin{aligned} \langle \chi(u[c]) \rangle &= \frac{1}{Z} \int_{b \in \Lambda^c} \prod du[b] \chi(u[c]) \exp \sum_{p \in \Lambda^c} \mathcal{L}(u[p]) \\ &\quad \cdot \prod_{i,r} \left\{ \hat{P}_{\Lambda_i^r, u}(\omega_o) \int_{\Gamma} d\sigma Z(\Lambda_i^r, u_\sigma) \right\} \end{aligned} \quad (2.16)$$

Here  $\hat{p}_{..}$  is the Fourier transform of  $p_{..}$ . It is defined by

$$\hat{P}_{\Lambda_i^r, u}(\omega) = \int_{\Gamma} d\gamma P_{\Lambda_i^r, u}(\gamma) \omega(\gamma) \quad (2.17)$$



for any character  $\omega$  of  $\Gamma$ .  $p_{..}(\gamma)$  was defined in Eq.(2.15).  
Eq.(2.16) is exact. We use it to derive a bound.

We note the identity

$$1 = \frac{1}{Z} \int_{b \in \Lambda^c} \pi du[b] \exp \sum_{p \in \Lambda^c} \mathcal{L}(u[p]) \prod_{i,r} \left\{ \int_{\Gamma} d\sigma Z(\lambda_i^r, u_\sigma) \right\}. \quad (2.18)$$

This is derived in the same way as (2.16). In place of  $\chi(u[c])$  one puts 1 in (2.7) and later formulae. As a result  $\omega_0$  gets replaced by the trivial character 1 everywhere later on. But  $\hat{p}_{..}(1) = 1$  since  $p$  is normalized,  $\int d\gamma p_{..}(\gamma) = 1$ .

Now we can write down the bound. We have  $|\chi(u[c])| \leq \chi(\mathbb{1})$  and  $|\hat{p}_{\Lambda_i^r, u}(\omega_0)| \leq \sup_u |\hat{p}_{\Lambda_i^r, u}(\omega_0)|$ . Therefore, using (2.18)

$$|\langle \chi(u[c]) \rangle| \leq \chi(\mathbb{1}) \prod_{i,r} \left\{ \sup_u |\hat{p}_{\Lambda_i^r, u}(\omega_0)| \right\} \quad (2.19)$$

The product goes over all vortex containers; they are labelled by  $i, r$  here. Inequality (2.19) has been derived without any approximations or extra assumptions. It is an inequality for the (confining) potential, cp. Eq. (1.2).  $\hat{p}_{..}$  is defined in Eqs.(2.15), (2.17).

To use it one has to know something about  $\hat{p}_{..}(\omega_0)$ . Let us consider the case  $G = SU(2)$ ,  $\Gamma = \mathbb{Z}_2$  as an example, with  $\chi(u) = \pm u$  so that  $\omega_0(\pm \mathbb{1}) = \pm 1$ . Since  $\int_{\Gamma} d\gamma (\dots) = \frac{1}{2} \sum_{\gamma} (\dots)$

$$\hat{p}_{\Lambda_i^r, u}(\omega_0) = \left( 1 - \frac{Z_{\Lambda_i^r, u_\sigma}}{Z_{\Lambda_i^r, u}} \right) \left( 1 + \frac{Z_{\Lambda_i^r, u_\sigma}}{Z_{\Lambda_i^r, u}} \right)^{-1} \quad (2.20)$$

with  $\sigma = -1$ . In terms of the change of free energy,  $\mu$ , that was introduced in Eq. (1.6) of the introduction this is ( $\beta = 1$  in this section).

$$\hat{p}_{\Lambda_i^r, u}(\omega_0) = \tanh \frac{1}{2} \beta \mu (-1)_{\Lambda_i^r, u} \leq \tanh \frac{1}{2} \xi_i^r$$

if

$$(2.21)$$

$$\xi_i^r = \max_u \beta \mu (-1)_{\Lambda_i^r, u}$$

Inserting this into inequality (2.19) and comparing with (1.2) we obtain the result (1.7) (cp. remark after Eq. (1.7)).

It remains to verify Eq. (1.9). We show that

$$Z(\lambda_i^r, u_\sigma) = Z(\lambda_i^r, u) \langle \mathcal{B}_\sigma[S_i^r] \rangle_{\lambda_i^r, u} \quad (2.22)$$

for  $\sigma = -1$ . This will be true for any  $u$ . Taking the same equation with  $u$  replaced by  $u_\sigma$  and dividing the two equations we obtain Eq. (1.9).

$Z(\lambda_i^r, u_\sigma)$  is defined by Eq. (2.12) with  $u$  replaced by  $u_\sigma$ . We make a variable transformation

$$u'[b] = \begin{cases} u''[b]\sigma & \text{if } b \in F_i^r \\ u''[b] & \text{otherwise} \end{cases}$$

Then

$$u'[\dot{p}] = \begin{cases} u''[\dot{p}]\sigma & \text{if } p \in S_i^r \\ u''[\dot{p}] & \text{otherwise} \end{cases}$$

Inserting this into Eq. (2.12) produces the desired result (2.22).

### 3 Abelian gauge theories in 3 dimensions.

In this section we will discuss application of our result (2.19) to an abelian gauge theory in 3 dimensions. To be specific, let us choose a gauge group  $G = U(1) = \Gamma$ . Its elements are complex numbers of mod-ulus 1

$$V = e^{i\varphi}, \quad \varphi = 0 \dots 2\pi, \quad dV = \frac{1}{2\pi} d\varphi$$

We assume that  $\mathcal{L}(V)$  is twice continuously differentiable. Hence we may define the coupling constant  $\beta^{-1}$  in the action (1.4a) by requiring

$$\max_{\varphi} \left\{ -\frac{\partial^2}{\partial \varphi^2} \mathcal{L}(e^{i\varphi}) \right\} = 1 \quad (3.1)$$

We consider the Wilson loop for a static quark of unit charge,

$$\chi(U) \equiv \omega_0(U) = U \neq 1$$

$\omega_0$  is the character of a 1-dimensional unitary irreducible representation of  $\Gamma (= G)$ .

We consider thin vortex containers  $\Lambda_i^r$  as were described after Eq. (2.4). We let them be densely packed, i.e. we choose  $a_i^r = i$ ,  $i = 0 \dots L-1$  in (2.3),  $r = \frac{1}{2}, \frac{3}{2}, \dots, T-\frac{1}{2}$ . There are then  $T$  identical layers  $\Sigma^r$  containing  $L-1$  vortex containers each.

There are then no links in the interior of  $\Lambda_i^r$ , and the set of plaquettes in  $\Lambda_i^r \setminus \partial\Lambda_i^r$  is exhausted by  $S_i^r$  (cp. Fig. 4). Therefore

$$Z(\Lambda_i^r, U_\gamma) = \exp \beta \sum_{p \in S_i^r} \mathcal{L}(U[p]_\gamma) \quad (\gamma = e^{i\varphi}) \quad (3.2)$$

There are  $4(2j+1)$  plaquettes in  $S_j^r$ . Let

$$A_j^r = \max_{\varphi} \sum_{p \in S_j^r} \mathcal{L}(U[p]e^{i\varphi})$$

and let the maximum be reached for  $\varphi = \varphi_0$ . Then, by Taylor

expansion in  $\varphi$  with Lagrange's estimate of the remainder  $R_1$  one deduces from (3.1) that

$$\sum_{p \in S_j^r} \mathcal{L}(U[p]e^{i\varphi}) \geq A_j^r - 2(2j+1)(\varphi - \varphi_0)^2$$

It follows that

$$\begin{aligned} (2\pi)^{-1} \int_{-\pi}^{\pi} d\varphi \exp \beta \sum_{p \in S_j^r} \mathcal{L}(U[p]e^{i\varphi}) &\geq e^{\beta A_j^r} (2\pi)^{-1} \int_{\varphi_0 - \pi}^{\varphi_0 + \pi} d\varphi e^{-2\beta(2j+1)(\varphi - \varphi_0)^2} \\ &\geq c_1(\beta) (2j+1)^{-1/2} e^{\beta A_j^r}, \end{aligned}$$

with  $c_1(\beta) \sim (8\pi/\beta)^{-1/2}$  for  $\beta \rightarrow \infty$ .

Therefore

$$\begin{aligned} 0 \leq P_{\Lambda_j^r, u}(e^{i\varphi}) &\equiv Z(\Lambda_j^r, u_{e^{i\varphi}}) \left[ \int Z(\Lambda_j^r, u_{e^{i\psi}}) d\psi / 2\pi \right]^{-1} \\ &\leq c_1(\beta)^{-1} (2j+1)^{1/2} \end{aligned} \quad (3.3)$$

In Appendix A it will be shown that inequalities (3.3) together with the normalization condition  $\int P_{\Lambda_j^r, u}(e^{i\varphi}) d\varphi / 2\pi = 1$  imply that

$$\hat{P}_{\Lambda_j^r, u}(\omega_0) \leq \exp -\frac{\pi^2}{6} c_1(\beta)^2 (2j+1)^{-1} \quad (3.4)$$

We insert this into our general result (2.19). This gives

$$\begin{aligned} \langle \chi(\gamma[C]) \rangle &\leq \chi(\mathbb{1}) \exp -\tau \frac{\pi^2}{6} c_1(\beta)^2 \sum_{j=1}^{L-1} (2j+1)^{-1} \\ &\leq \chi(\mathbb{1}) \exp -\tau c_2(\beta) [\ln L + \text{const.}] \end{aligned} \quad (3.5)$$

with  $c_2(\beta) = \frac{\pi^2}{12} c_1(\beta)^2 \sim \text{const} \cdot \beta^{-1}$  as  $\beta \rightarrow \infty$ . This shows that inequality (1.2) is satisfied for

$$V(L) = c_2(\beta) [\ln L + \text{const.}] \quad (3.6)$$

Acknowledgement: The authors are indebted to M. Lüscher and H. Joos for discussions, and to the Deutsche Forschungsgemeinschaft for financial support.

Appendix A. A bound for Fourier coefficients of probability distributions on the circle group.

We consider the compact abelian group  $\Gamma = U(1)$ . It consists of elements  $z = e^{i\varphi}$ ,  $-\pi < \varphi \leq \pi$ . Normalized Haar measure is  $d\varphi/2\pi$ . Probability distributions  $p(z)$  are (measurable) functions satisfying

$$p(z) \geq 0 \quad ; \quad \int_{-\pi}^{\pi} p(e^{i\varphi}) d\varphi/2\pi = 1 \quad (A.1)$$

They possess Fourier transforms

$$\hat{p}(\ell) = \int_{-\pi}^{\pi} p(e^{i\varphi}) e^{i\ell\varphi} d\varphi/2\pi \quad ; \quad \ell = 0, \pm 1, \dots \quad (A.2)$$

Because of Eq. (A.1),  $\hat{p}(0) = 1$ . Suppose that

$$p(z) \leq A \quad \text{for all } z \quad (A.3)$$

We will show that this implies

$$|\hat{p}(\ell)| \leq \exp -\frac{\pi^2}{6} A^{-2} \quad \text{for } \ell \neq 0 \quad (A.5)$$

[Remark: In applications, this result serves as a substitute for the central limit theorem on the circle group. For instance, by using it, the results of ref. [5] can be sharpened so that they imply a power law decay of the 2-point spin correlation function (as was proven by another method in ref. [16]). Consider a sequence  $p_n(z)$ ,  $n = 1, 2, \dots$  of probability distributions, and the convolution products

$$p^{(N)}(z) = p_1 * \dots * p_N(z) = (2\pi)^{-N} \int \dots \int d\varphi_1 \dots d\varphi_N \delta(z \prod_1^N e^{-i\varphi_k}) \prod_1^N p_k(e^{i\varphi_k})$$

(The  $\delta$ -function with support at 1 is defined by  $\int \delta(z) f(z) d\varphi/2\pi = f(1)$ ).

Suppose that  $p_n(z) \leq A_n$  for all  $z$ . Then

$$|\hat{p}^{(N)}(\ell)| = \prod_1^N |\hat{p}_k(\ell)| \leq \exp -\frac{\pi^2}{6} \sum_{k=1}^N A_k^{-2} \quad \text{for } \ell \neq 0$$

As a consequence,  $p^{(N)}(z) \rightarrow 1$  as  $N \rightarrow \infty$  in an appropriate topology if  $\sum_{k=1}^{\infty} A_k^{-2} = +\infty$ . ]

Proof: We want to find the maximum of  $|\hat{p}(\ell)|$  subject to constraints (A.1). First we note that  $\hat{p}(\ell)$  changes by a phase factor if we substitute  $p(e^{i[\varphi-\varphi_0]})$  for  $p(e^{i\varphi})$ . Therefore we may assume without loss of generality that  $\hat{p}(\ell)$  is nonnegative real. In this case  $\hat{p}(\ell) = \int \cos \ell\varphi p(e^{i\varphi}) d\varphi / 2\pi$ . Consider first the case  $\ell=1$ . It is evident that the maximum of  $\hat{p}(1)$  is reached for

$$p(e^{i\varphi}) = \begin{cases} A & \text{for } |\varphi| \leq \pi A^{-1} \\ 0 & \text{otherwise} \end{cases} \quad (\text{A6})$$

This gives

$$\hat{p}(\ell) \leq \frac{A}{\pi} \sin \pi A^{-1} \quad (\text{A7})$$

for  $\ell=1$ . For general  $\ell \neq 0$  the maximum is reached for a function which remains invariant under  $\varphi \rightarrow \varphi + 2\pi/\ell$ . A variable substitution  $\varphi' = \ell\varphi$  then reduces the problem to the case  $\ell=1$ . As a result, inequality (A7) is generally true for  $\ell \neq 0$ .

The inequality  $p(e^{i\varphi}) \leq A$  can only be true for  $A \geq 1$ . We can therefore use the inequality

$$-\ln \frac{1}{x} \sin x \geq \frac{x^2}{3!} \quad \text{for } 0 < x \leq \pi \quad (\text{A8})$$

Setting  $x = \pi A^{-1}$  we deduce (A.5) from (A.7).

References

1. A.M.Polyakov, Phys. Lett. 59 B (1975)79; Nucl. Phys. B 120 (1977) 429.  
A.A.Migdal, Zh. Eksp. Teor. Fiz. 69 (1975) 810, 69 (1975) 1457.  
L.Kadanoff, Rev. Mod. Phys. 49 (1977) 267.
2. G.t'Hooft, Nucl.Phys. B 138 (1978) 1.
3. D.Foerster, Phys.Lett. 76 B (1978) 597.  
J.Glimm, A.Jaffe, Charges, Vortices and Confinement, preprint Harvard, 1978.
4. M.Fisher, J. Appl. Phys. 38 (1967) 981.
5. R.L.Dobrushin, S.B.Shlosman, Commun. Math. Phys. 42 (1975) 31.
6. K.Wilson, Phys. Rev. D 10 (1974) 2445.
7. T.Yoneya, Z(N) Topological Excitations in Yang - Mills Theories: Duality and Confinement, preprint City College of New York, 1978.
8. G.Mack, V.Petkova, Comparison of Lattice Gauge Theories with Gauge Groups  $Z_2$  and  $SU(2)$ , DESY preprint 78/68 (Nov. 78).
9. Z.F. Ezawa, Quantum field theory of vortices and instantons, talk presented at DESY (June 1977),  
Phys. Rev. D 18 (1978) 2091; see also  
H.C. Tze, Z.F. Ezawa, Phys. Rev. D 14 (1976) 1006.
10. F. Englert, private communication (April 77),  
Electric and magnetic confinement schemes, Cargese lectures 1977;  
F. Englert and P. Windey, Dynamical and topological considerations on quark confinement, Les Houches lectures 1978.
11. G. Mack, Physical principles and geometric aspects of gauge field theories (in preparation).
12. J. Glimm, A. Jaffe, Phys. Lett 66B (1977) 67.
13. G. Mack, Phys. Lett. 78B (1978) 263.
14. V.P. Gusynin, V.A. Miransky, Phys. Lett. 76B (1978) 585.
15. C.G. Callan, R. Dashen, D.J. Gross, Phys. Rev. D 16 (1977) 2526;  
see also the discussion of the 2-dimensional models in  
M. Lüscher, The secret long range force in quantum field theories with instantons. preprint NBI-HE-78-19 (Copenhagen, June 1978).
16. O. Mc Bryan and T. Spencer, Commun.Math.Phys. 53 (1977) 299.

Figure captions.

Figs. 1. Vortex containers  $\Lambda_i$  winding around the path C.

(a) 3-dimensional case.

(a), (b), (c) 4-dimensional case.

Fig. 2. A possible arrangement of vortex containers winding around the path C. The figure shows their intersection with the  $x^1 x^2$ -plane.

Fig. 3. Path C and one of the layers  $\Sigma^r$ .

Fig. 4. Set  $\tilde{S}_i^r$  of links in  $\Sigma^r$  (heavy lines) and plaquettes  $p \in S_i^r$  attached to them (squares). Drawing for 3 dimensions.

Fig. 5. Relative position of various subsets of a layer  $\Sigma^r$ .  $F_i$  consists of the timelike links between  $\tilde{S}_{i-1}$  and  $\tilde{S}_i$ , including those in  $\tilde{S}_{i-1}$ , but not those in  $\tilde{S}_i$ .  $F_{s_r+1}$  is outside  $\tilde{S}_{s_r}$  ( $s_r = 3$  in the drawing). Dotted areas are in the interior of vortex containers  $\Lambda_i$ . Superscripts  $r$  are dropped.



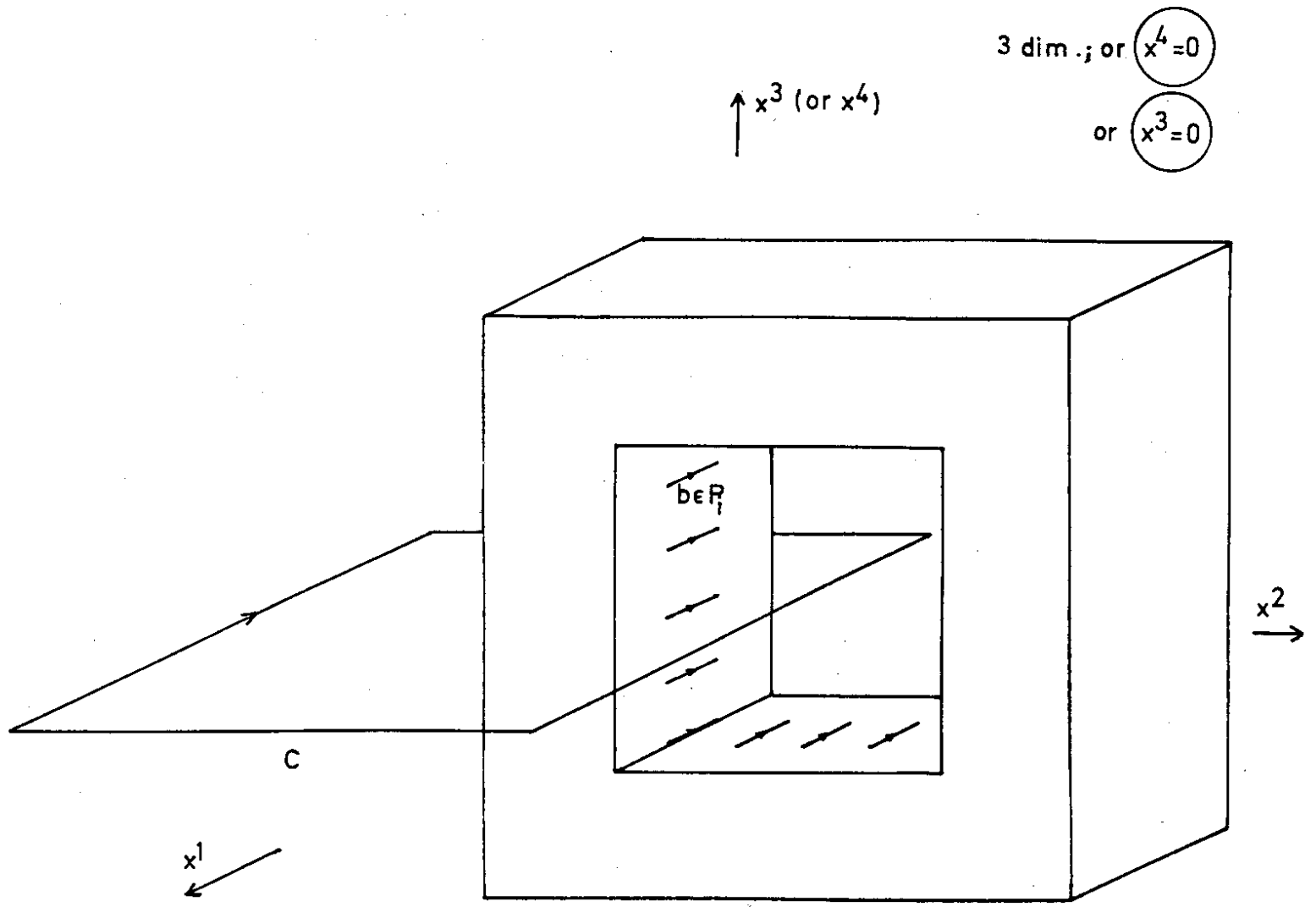

Fig.1a

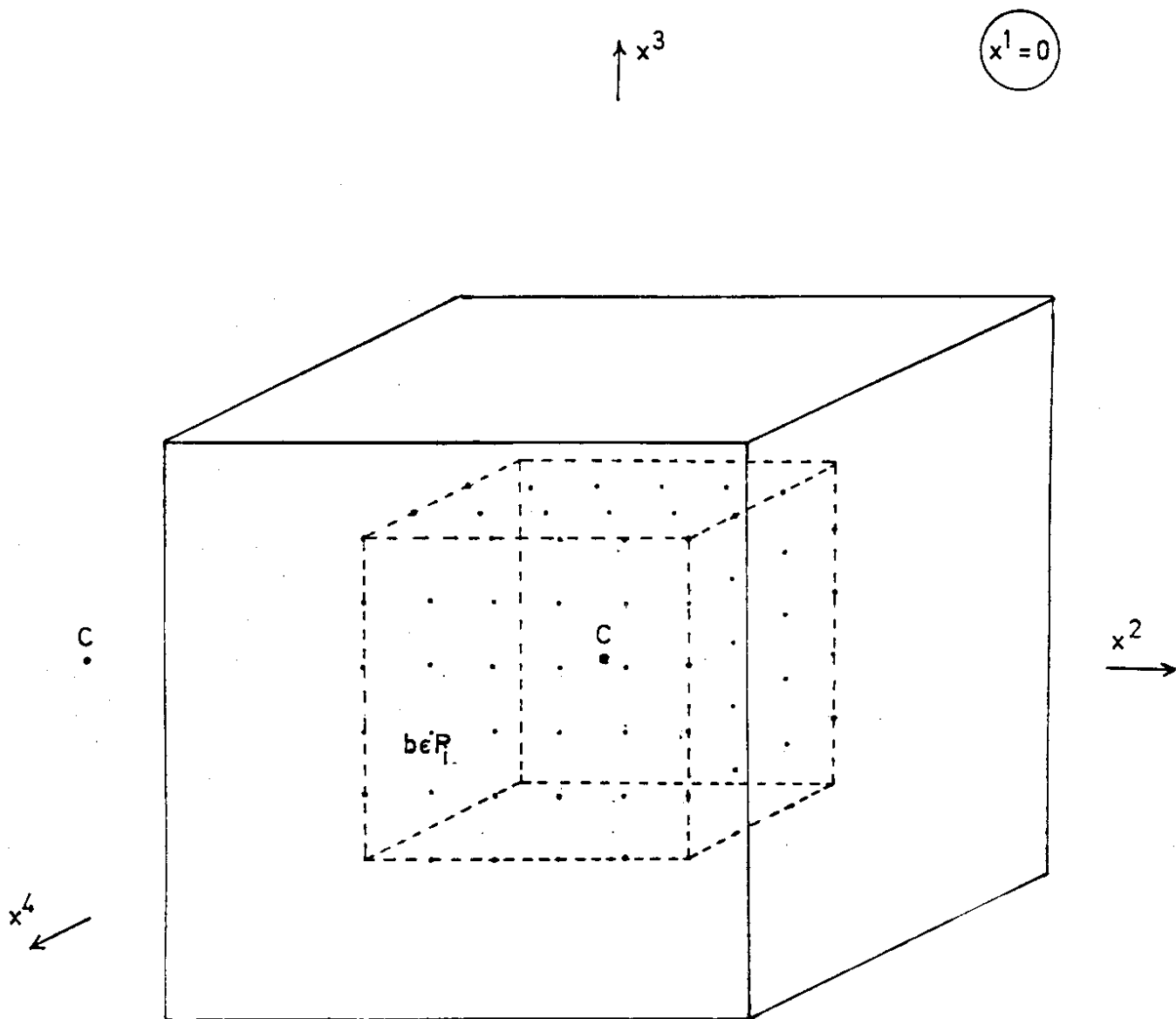

Fig.1b

$$x^2 = 0$$

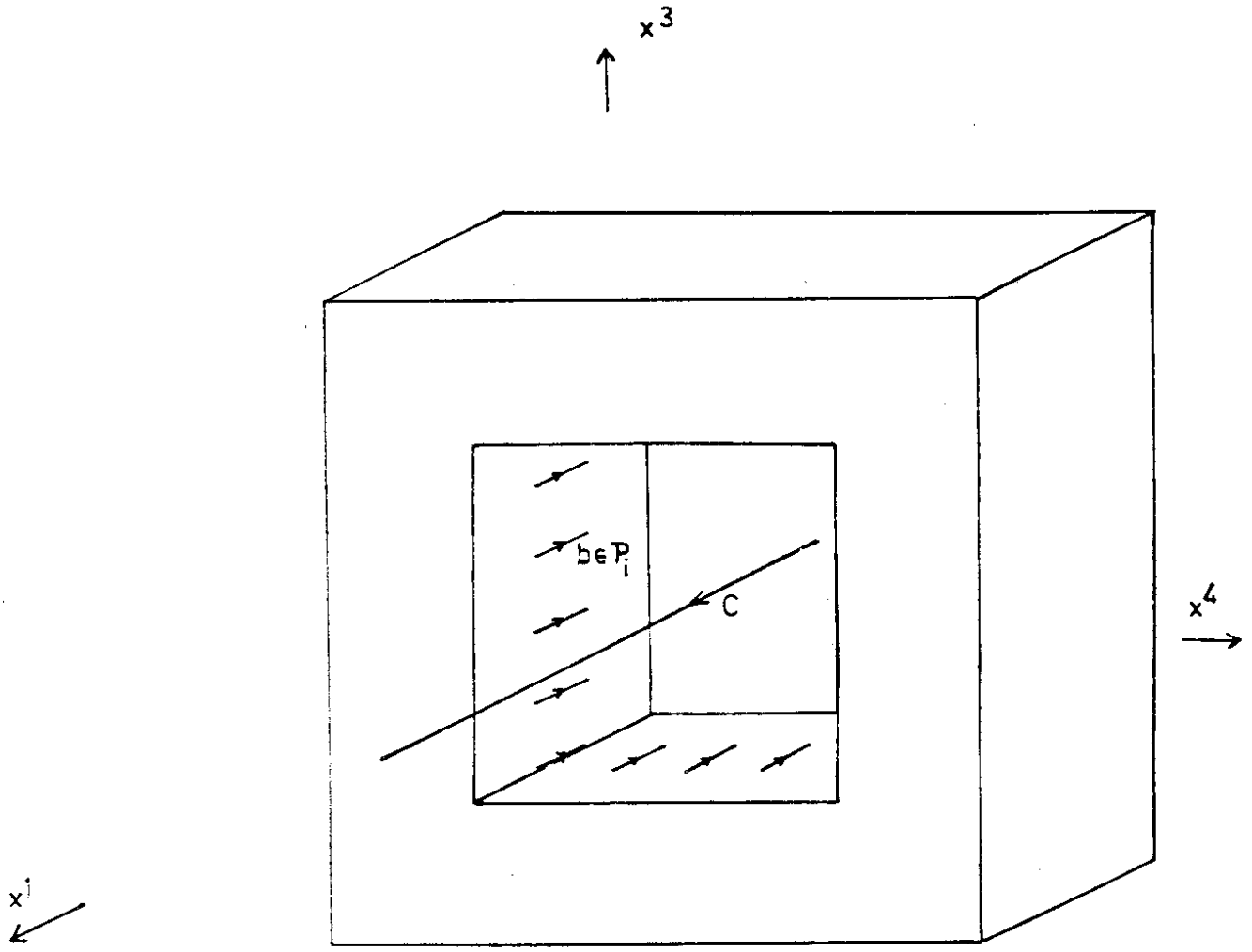

Fig.1c

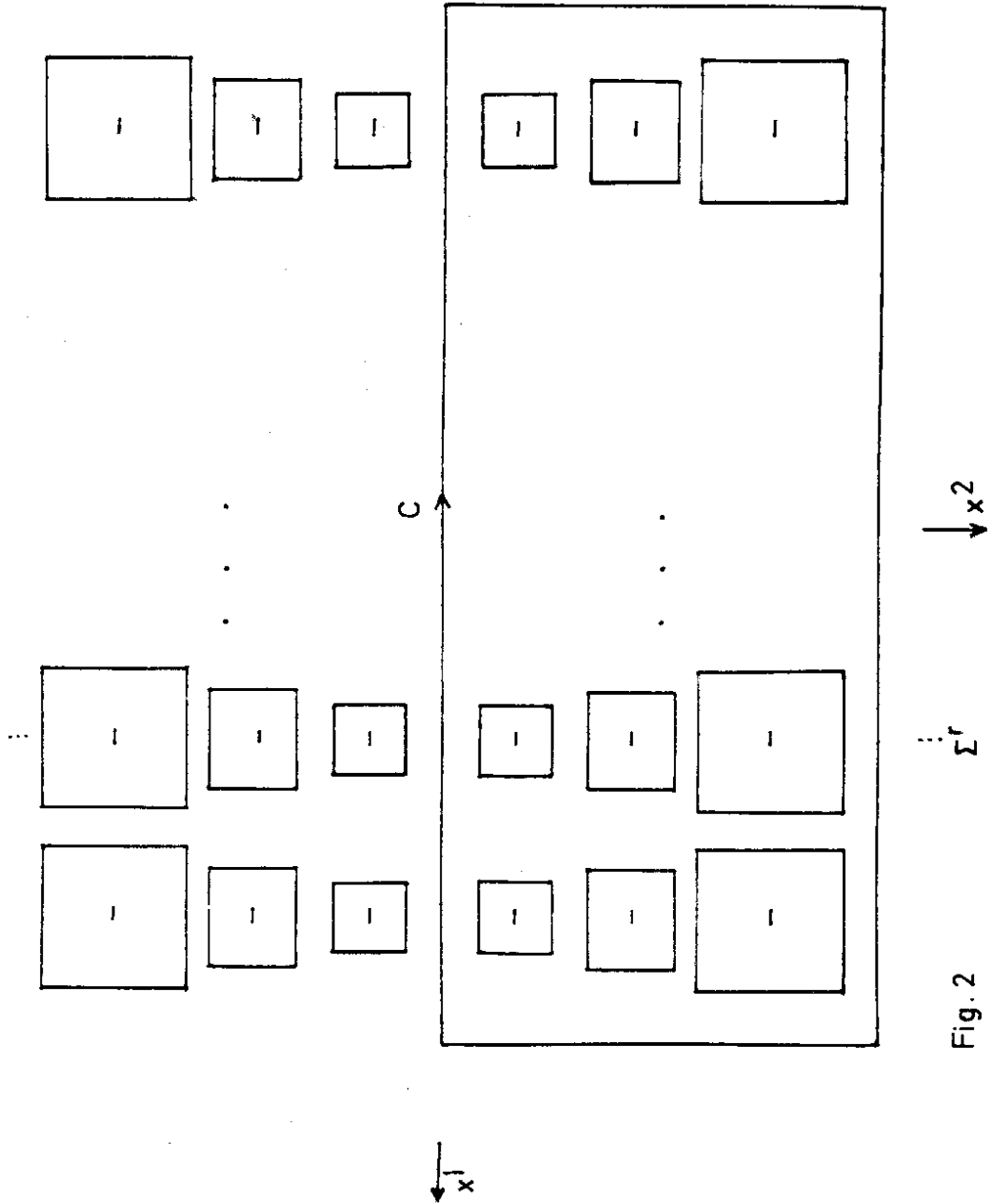

Fig. 2

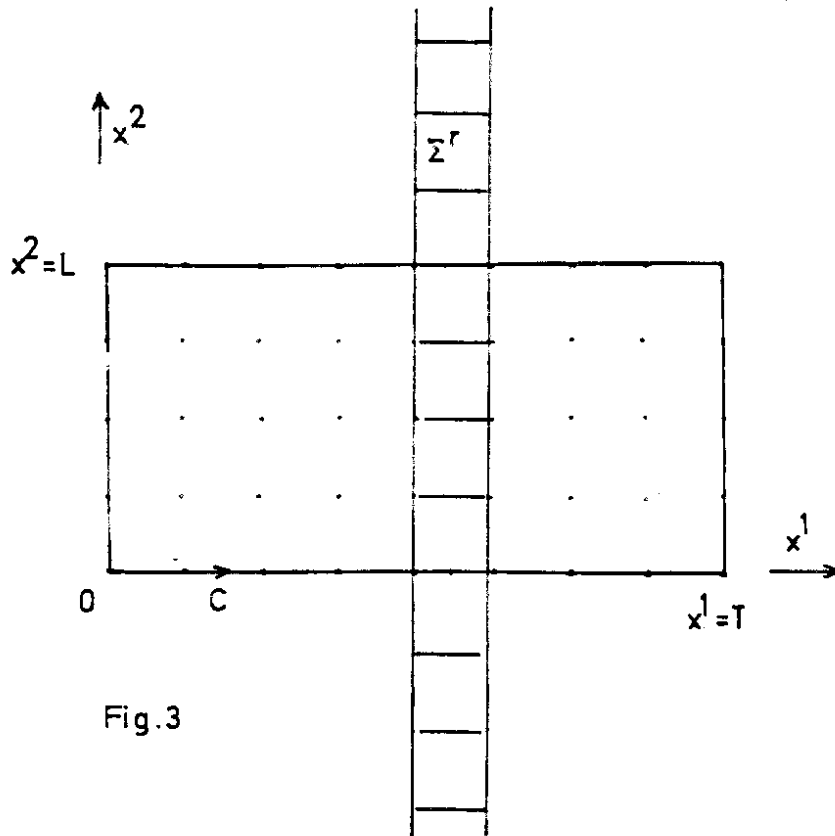

Fig.3

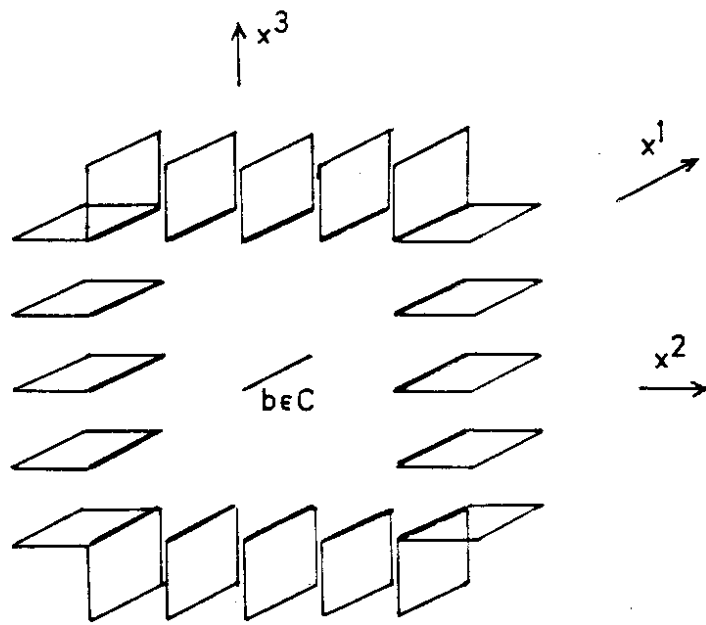

Fig. 4

$\Sigma^r$

$x^3$

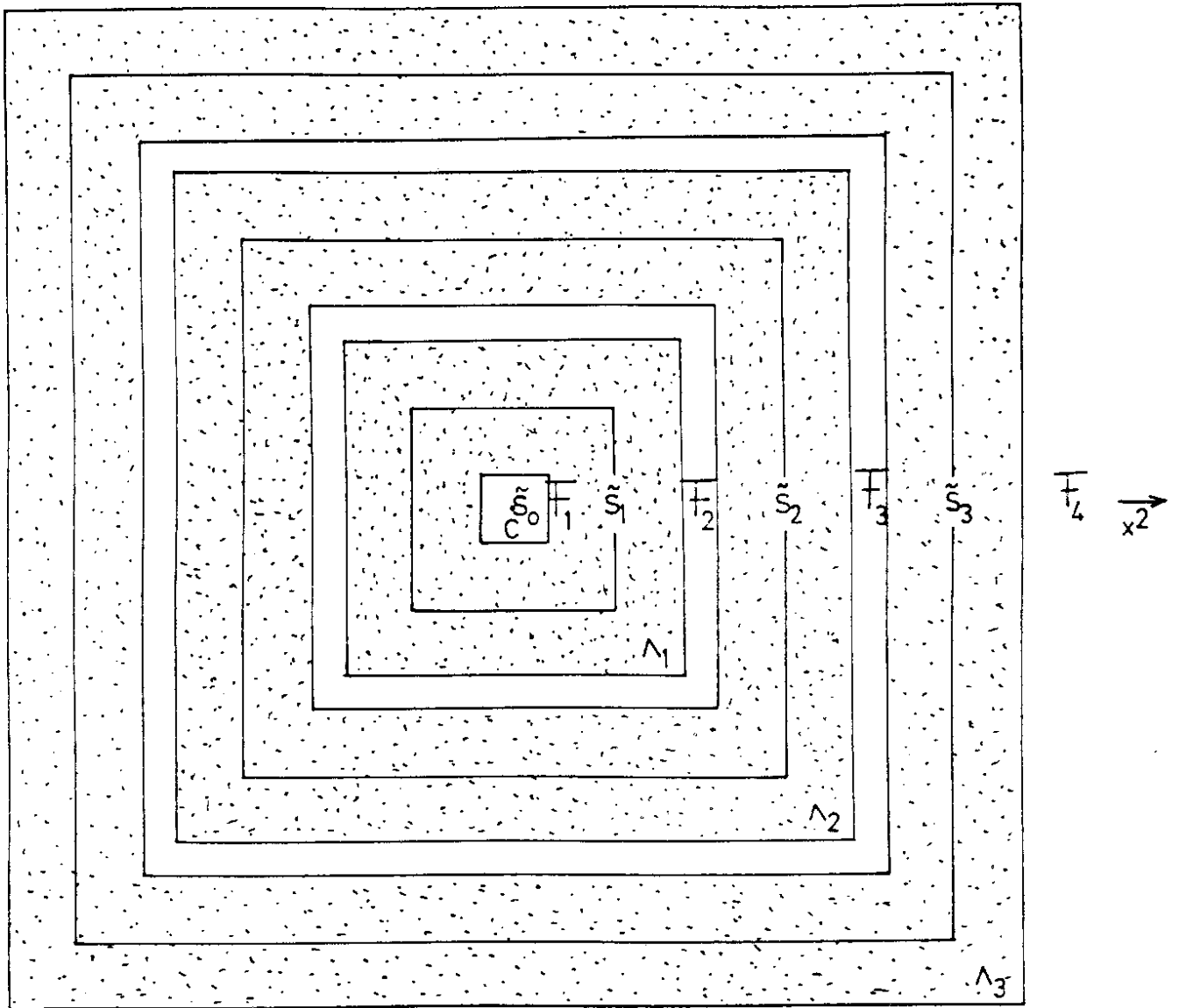

Fig.5

c