



UNDERSTANDING AQUACULTURE



Cover illustration by Emanuela D'Antoni

UNDERSTANDING AQUACULTURE

FOOD AND AGRICULTURE ORGANIZATION OF THE UNITED NATIONS
Rome, 2005

The designations employed and the presentation of material in this information product do not imply the expression of any opinion whatsoever on the part of the Food and Agriculture Organization of the United Nations concerning the legal or development status of any country, territory, city or area or of its authorities, or concerning the delimitation of its frontiers or boundaries.

ISBN 92-5-105382-0

All rights reserved. Reproduction and dissemination of material in this information product for educational or other non-commercial purposes are authorized without any prior written permission from the copyright holders provided the source is fully acknowledged. Reproduction of material in this information product for resale or other commercial purposes is prohibited without written permission of the copyright holders. Applications for such permission should be addressed to the Chief, Publishing Management Service, Information Division, FAO, Viale delle Terme di Caracalla, 00100 Rome, Italy or by e-mail to copyright@fao.org

© FAO 2005

UNDERSTANDING AQUACULTURE

This document is a simplified version of the FAO Technical Guidelines for Responsible Fisheries 5 – Aquaculture Development and intends to provide some insight into the importance, opportunities and challenges in responsible aquaculture development as agreed by the FAO member states under the Code of Conduct for Responsible Fisheries (CCRF). The document highlights the important and critical areas which require careful consideration during planning, plan implementation and management of aquaculture at national and regional levels. The document draws on the provisions given in Article 9 of the Code – *Aquaculture Development*.

Background and introduction

Most people understand that fisheries are a renewable resource that cannot provide an endless supply of fish. Marine and inland fisheries will not be sustainable unless we manage them more carefully. Towards that end, on 31 October 1995, the twenty-eighth Session of the Conference adopted the Code of Conduct for Responsible Fisheries. The Code was developed by FAO and takes into account the many discussions with representatives from United Nations agencies, other international organizations and non-governmental organizations who have actively contributed since 1982. The Code of Conduct for Responsible Fisheries is meant to be applied along with a number of other important conventions and agreements including the:

- United Nations Convention on the Law of the Sea, 1982;
- Agreement for the Implementation of the Provisions of the United Nations Convention on the Law of the Sea of 10 December 1982 Relating to the Conservation and Management of Straddling Fish Stocks and Highly Migratory Fish Stocks, 1992;
- 1992 Declaration of Cancun, and
- 1992 Rio Declaration on Environment and Development, in particular, Chapter 17 of Agenda 21.

These are *voluntary* guidelines. Individuals or groups can use these guidelines as a checklist of issues that should receive attention when developing aquaculture.

Because of the extreme diversity in almost every aspect of aquaculture and fisheries, readers should use these guidelines in accordance to their needs. For example the legislative aspect may be strong in one country and be the first priority of concern in another. Long term progress towards workable Codes of Conduct in individual countries will be made in small steps. In the meantime, everyone involved can point to small successes elsewhere to argue for their adoption at home.

Interested readers are invited to help FAO by sending information on related technical, policy or legal matters which might be useful in updating, evaluating and improving the Guidelines and in developing more information materials to promote responsible development of aquaculture.



Further information on the Code and its provisions can be obtained at:

<http://www.fao.org/fi/agreem/codecond/codecon.asp>

Responsible development of aquaculture in areas under national jurisdiction (CCRF Article 9.1)

Understanding and enforcement of aquaculture legislation

National governments need to make policies, laws and regulations specifically for people who want to develop and promote responsible aquaculture practices. Existing administrative and legal systems may need to be adjusted to meet these needs by describing privileges and responsibilities and how laws, regulations and orders are communicated to everyone in a way that can be understood and enforced.

A general responsibility of Government should be to work with people and groups in civil society to promote environmentally sound and sustainable aquaculture that is well coordinated with rural, agricultural and coastal development plans and activities and raise awareness of the general public so they understand the many benefits of aquaculture to themselves and others.

Advance evaluations of genetic affects

One of the big concerns about aquaculture is biodiversity. Genetic changes can be caused by introduced species, domesticated species or species that have been genetically modified by aquaculture breeding programmes or other technology. Negative affects from changes in the genes of a species can include:

- contamination of the gene pool of a native species through hybridization;
- less suitable native species (e.g. smaller size, poor taste, lower market price) or the complete loss of a species, and
- change in the mix of native species caused by competition, predators or damage to the native habitat.

The risk of these negative affects can be estimated in advance if people think about:

- the possibility that a cultured species will escape into the natural environment;
- the chances of an escaped species being able to survive in the natural environment;
- if the escaped species can breed with other fish, and
- the ability of the genes of the escaped species to transfer to native species.

Aquaculture development and planning

An aquaculture development plan should describe the responsibilities of all the people concerned and should suit the needs of the area by taking into account the local social and economic conditions.

The plan should also describe how people can participate in the planning process, help put the plan into action and help enforce the Code of Conduct for Responsible Fisheries they develop and adopt.

Responsible use of land and water resources and acceptable levels of impact on the environment

Government agencies can make suitable environmental impact assessments before setting up aquaculture farms with procedures in place to measure water use, effluents, use of drugs and chemicals and other farm activities that might affect nearby water and land. Environmental assessment and monitoring is an important area for cooperation between government agencies, researchers and fish farmers, but procedures should be flexible to fit different types of operations. Aquaculture activities need be located in places that are physically suitable for sustainable production, are economically and socially suitable, prevent or minimize conflicts with other people and respect nature reserves, protected areas and critical or sensitive habitats.

Government agencies need to ensure that the privileges and needs of the aquaculture sector are recognized and respected by other users of land and water resources and that aquafarms are not in danger from environmental problems caused in other sectors.

Zoning or site regulations need to consider plans for regional development and river basin or coastal area management. Zoning often requires cooperation and capacity building in areas such as: assessing and monitoring resources, planning use of resources across different sectors, environmental accounting, conflict resolution and getting stakeholders to take part in the decision-making processes.

Institutional capacity for aquaculture

In most cases, the institutional arrangements that governments use to develop and support aquaculture come from forestry, fishery and other natural resource management agencies. These arrangements are useful for dealing with biological, marketing and food quality issues but governments need to strengthen links between aquaculture and related agencies such as rural development, irrigation, tourism and health. Aquaculture and fishery experts need to find ways of taking part in making economic and legal policy and regulations for water management.

Promoting appropriate development and technology while ensuring the livelihoods of local communities

Proposed aquaculture development projects may not be given enough careful thought in advance, because many countries do not have a lot of experience in the aquaculture sector. Government officers working together with aquaculture experts, fish farmers and investors should think carefully about the possible benefits and consequences of aquaculture projects to make sure they will help increase the food supply and improve economic and social conditions in rural communities without any serious negative impacts.

Expanding food production is one of the main ways of increasing food supply and income for people living in poverty. The livelihoods of poor people living in rural communities depend on their being able to produce food in a number of ways. Some of these ways may include land and aquatic farming, fishing and use of forest products. The need for food production to expand, intensify, specialize or diversify often comes into conflict with traditional practices.

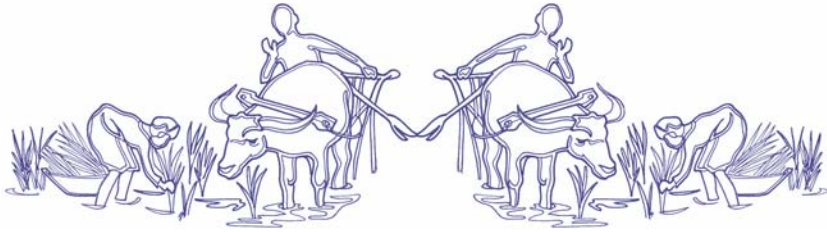

Responsible development of aquaculture and culture-based fisheries in transboundary aquatic ecosystems (CCRF Article 9.2)

Protecting transboundary aquatic ecosystems

Countries with aquaculture activities in or bordering international waters should accept their obligations to neighboring countries to make responsible choices about fish species used for culture and for the location and management of aquaculture activities. Government officers, fishery managers and fish farmers need to be aware of the affects that some aquaculture practices can have on transboundary aquatic ecosystems if they are not managed carefully.

There is more opportunity for cooperation at the sub-regional and regional level. Government agencies, private sector associations, researchers and other concerned people in different countries may find it useful to join together to develop and transfer technology, exchange market information, do research and training and develop measures to handle natural and human-made disasters.

Choice of species, distribution, siting and management

Choice of species for culture should be based on biological, environmental and socio-economic criteria. Culture-based fisheries deserve special attention because the purpose of aquaculture is to produce an organism that can survive in nature. Living organisms usually escape into the environment, even in contained aquaculture systems. For this reason, several groups have recommended the use of native species over introduced species. In light of these developments, Government officers need to:

- be aware that genetically altered species can have negative affects on biological resources and on communities of people who depend on these resources for their livelihoods;
- monitor and control any species introduced into their country;
- make sure that aquafarms are located in places and managed in a way to avoid negative environmental impacts, and
- prevent transfer of pathogens and subsequent outbreaks of disease that may affect fisheries resources or activities in other countries.

Governments should inform each other about outbreaks of diseases which can be transmitted through transboundary ecosystems. They should make plans to cooperate at the sub-regional and regional levels to try to contain or stop any disease outbreaks.

Role of regional fisheries bodies, information sharing and regional cooperation

Neighbouring countries can set up procedures for consulting with each other about introducing non-native species. In cases where there are no regional fishery bodies

or organizations, the countries concerned may set them up. Fisheries agencies should also consult each other about introducing genetically altered organisms. Topics for discussion should include:

- the species, its country of origin and the number introduced;
- breeding programmes or genetic modification used on the organism;
- location of aquaculture sites and possible routes of dispersion;
- expected benefits;
- expected and potential problems;
- monitoring programmes and emergency plans, and
- reporting the introduced species to FAO

The demand for global, regional and national aquaculture data is growing rapidly. There is a need for data and statistics on production, areas under cultivation, types and capacities of production systems, resource use and employment in the aquaculture sector and related services. There is also strong interest in information on domestic and international demand for aquaculture products, including consumption patterns, product prices, trade and market opportunities.

Cooperation can be strengthened among fish farmers, fish farmers' associations, suppliers, product processors and traders, to improve data collection, analysis and interpretation and to share data and information through regional and international organizations of which they are members.

Governments can help by supporting efforts to improve cooperation in capacity building and research on aquaculture systems and by improving procedures for exchanging knowledge, experience and technical assistance

to support sustainable development practices. For example, fisheries would benefit from fair trade in equipment, feeds and other inputs. Aquaculture also needs special equipment and supplies. These are often in limited supply or difficult to get in some regions. There is a need, therefore, to improve cooperation to set up production facilities and to promote trade in such equipment and supplies within and between regions. Suitable control mechanisms should be in place to monitor the quality of materials.

Use of genetic resources for aquaculture and culture-based fisheries (CCRF Article 9.3)

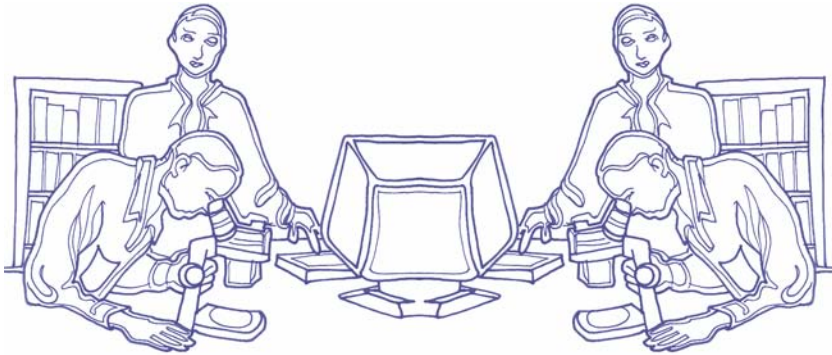

Maintaining genetic diversity through management

Genetic diversity provides the basis for improving aquaculture production. However, aquaculture practices can affect genetic diversity at many levels by changing species, communities of fish and ecosystems. Risk assessment and monitoring systems are needed to protect these genetic resources. For example, simple records of management of wild genetic resources are useful as a benchmark for measuring later impact. Information databases are needed on aquatic genetic resources for both farmed and wild

species. Aquaculture stocks or stocks for culture-based fisheries can be managed within the culture facility to avoid inbreeding and maintain stock integrity by not hybridizing different stocks, strains or species and by transferring the minimum amount of genetically different stocks. This is assisted by regular assessment of genetic diversity using laboratory analysis.

Natural levels of genetic diversity can be maintained by reducing the movement of diverse populations or using genetic technologies to culture non-reproductive organisms. Public education on the safety and ethics of genetic technologies is needed to make sure aquaculture products are acceptable to consumers.

Individuals and groups need to be aware that there is already legislation in many countries that governs the use and transport of species outside of their natural range. For example, the ICES/EIFAC Code of Practice and the Nuisance Species Protection Act USA are intended to control introduced species.

Several sets of regulations govern the use, transport and release into the environment of genetically altered organisms. These include the:

- Directives of the European Union;
- Performance Standards of the USDA, and the
- ICES Code of Practice

The Convention on Biological Diversity (CBD) has prepared biosafety rules for the safe use of genetically modified organisms. Other sources of information are databases on international introductions of aquatic animals and aquatic animal pathogens, usually available on the Internet. International codes of practice need to be adapted for developing countries.

Guaranteeing quality, performance, ecological safety, seed and broodstock

Aquaculture agencies can promote responsible practices for genetic improvement of broodstocks and the production, sale and transport of eggs, larvae or fry or other living organisms. Governments can help by developing guidelines and regulations on acceptable genetic technologies and breeding practices. International codes of practice may include plans for development of national guidelines and procedures on the use of genetically altered species.

Few fish farmers have the training and experience needed to use genetic technologies without losing genetic fitness. Farmers can maintain a high level of genetic diversity by: breeding as many fish as possible, using brooders and eggs from the entire spawning season, avoiding full-sibling or parent-offspring mating and keeping careful records of production practices.

Aquaculture can help protect and improve stocks of endangered species. As a conservation measure, endangered species can be kept temporarily in hatchery and culture facilities while efforts are being made to restore the natural habitat or reduce or remove threats to the species. Governments can play a key role in supporting these efforts by exploring genetic technologies to identify genetically compatible or suitable broodstock, determining the taxonomy of the endangered species and by making sure there is a good supply of gametes by freezing sperm (cryopreservation) from endangered or closely related species.



Responsible aquaculture at the production level (CCRF Article 9.4)

Promoting responsible practices and attitudes in aquaculture development

Most aquaculture production is in developing countries in Asia where it is an important source of nutrition and income, especially for poor people in rural communities. Production, processing and sale of fish helps improve nutritional health, is a source of protein, provides income and increases food security. Exports of high-value species are an important source of foreign currency. Hence, there is a general trend worldwide toward more intensive aquaculture systems for high-value species. These systems are often set up in sensitive coastal areas where they can increase the risk of environmental damage.

Government agencies need to work with stakeholders to develop standards for responsible aquaculture, help farmers set up fish farmer groups and producer associations and support cooperation between private sector, government agencies, research institutions and other food producer groups.

Benefits of association and self-regulation

There are definite benefits to membership in producer organizations and developing voluntary codes of practice and guidelines:

- Aquaculturists are in a better position to defend their interests and to negotiate with competing interests for rights and privileges.
- Codes of practice and standard guidelines help improve the public image of aquaculture.
- There is more common understanding and agreement among aquaculturists on what steps can be taken to make sure development is sustainable.
- Roles and responsibilities of people, interest groups and institutions can be negotiated and made clear.
- Associations can work effectively with other sectors for best use of resources that should be shared with aquaculture and fisheries.

Participation in research, training, extension and capacity building at farm level

Individuals and agencies in rural areas usually do not have enough resources (technical, financial, educational, training, etc.). Aquaculturists should look to government, local aquaculture agencies, farmers in local communities, development agencies, foundations and the private sector for help in mobilizing resources. Researchers can help to improve sustainable aquafarming methods. Fish farmers and people in local communities should be involved in setting research goals and objectives and discussing the results with researchers.

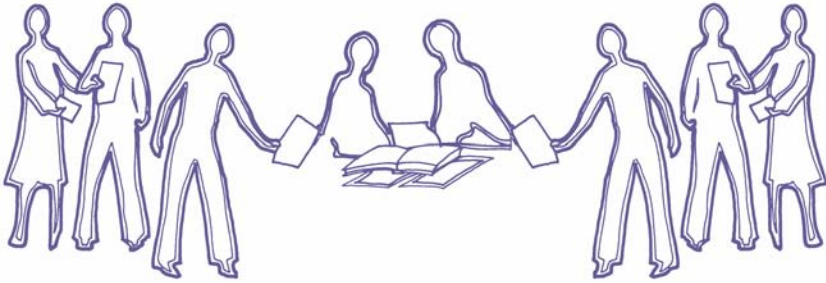

Labeling inputs used in aquaculture

Governments have a key role to play in making sure that inputs such as equipment, feeds and chemicals are properly labeled. Important information and instructions on using these inputs should be made available in local languages and in a form understandable to people unable to read text.

Record keeping

Aquaculturists need to keep records on many aspects of their operation. In addition to their value as a management tool, records are useful in cases of outbreaks of disease and accidents and can help farmers defend aquaculture operations against claims of poor management or careless actions.

Stress management and fish health maintenance

A good quality environment is the first and best method of controlling infectious diseases because it reduces the stress on the organism under culture. Stress is caused by changes in the physical, chemical, biological or microbial quality of the environment, the feed used and the space available. Stress can be reduced by using suitable stocking

densities and providing good conditions. Farmers, extension workers and fish health experts can cooperate to increase awareness and knowledge of how to manage and maintain a healthy environment.



Interactions with predatory wildlife

Birds and aquatic mammals that eat fish and other cultured organisms can damage fish stocks, nets and other equipment and transfer diseases. Farmers should try every practical method available to keep predators away from their stocks. Killing should be considered a last resort.

Environmental management for enhancement of fishery yields

In many countries there are under-used water bodies that have potential for fish production. When planning to farm fish in these water bodies, planners need to consider existing rights for using these water bodies and possible affects on the environment and local communities in addition to financial costs and benefits. Local stakeholders should be involved in planning and management, especially in plans for rehabilitation or recreational uses of aquatic environments.

Selection and use of feeds and additives

Responsible use of feeds and feed additives contributes to efficient production because there is less

waste and less impact on the environment. Feed manufacturers and suppliers have a responsibility to provide suitable feeds and to help farmers use these feeds for best results. The use of locally available feeds should be encouraged. Responsible use of feed additives, including antibiotics and growth hormones requires extra care.

Selection and use of manures and fertilizers, use of drugs, antibiotics or other chemicals to control disease

Responsible use of human and animal manures can contribute to safe and efficient recycling of nutrients in semi-intensive and extensive pond-based farming systems. Care must be taken to make sure the product does not become contaminated with pathogens, parasites, heavy metals, antibiotics or other substances harmful to consumers.

Fish farmers should have a suitable range of tested and approved materials to treat aquatic diseases and training guidelines for their use. If possible, a veterinarian or qualified person should supervise the use of these materials. The government should strictly control or prohibit the use of drugs that have not been certified. Farmers should avoid using antibiotics for prevention of diseases so fish do not build up drug resistance.

Governments can help develop practical guidelines and regulations on the use of chemicals and describe in detail how they will be enforced. Fishfarmers, researchers and manufacturers of drugs and agricultural chemicals can cooperate to test and license chemicals for use in aquaculture. These groups should also be involved in making policy, laws and regulations on the production, distribution and use of chemicals that are known to be harmful to human health and the environment.

This booklet describes, in a non-technical manner, some important aspects of FAO Technical Guidelines for Responsible Fisheries No. 5 dealing with aquaculture development. The purpose of this booklet is to help familiarize FAO Members and other stakeholders with the goals and practices of responsible aquaculture development. The booklet does not replace Technical Guidelines No. 5 but simply presents some of the complex information contained in those guidelines in a simplified form in an attempt to make it more accessible to all those involved in aquaculture development.

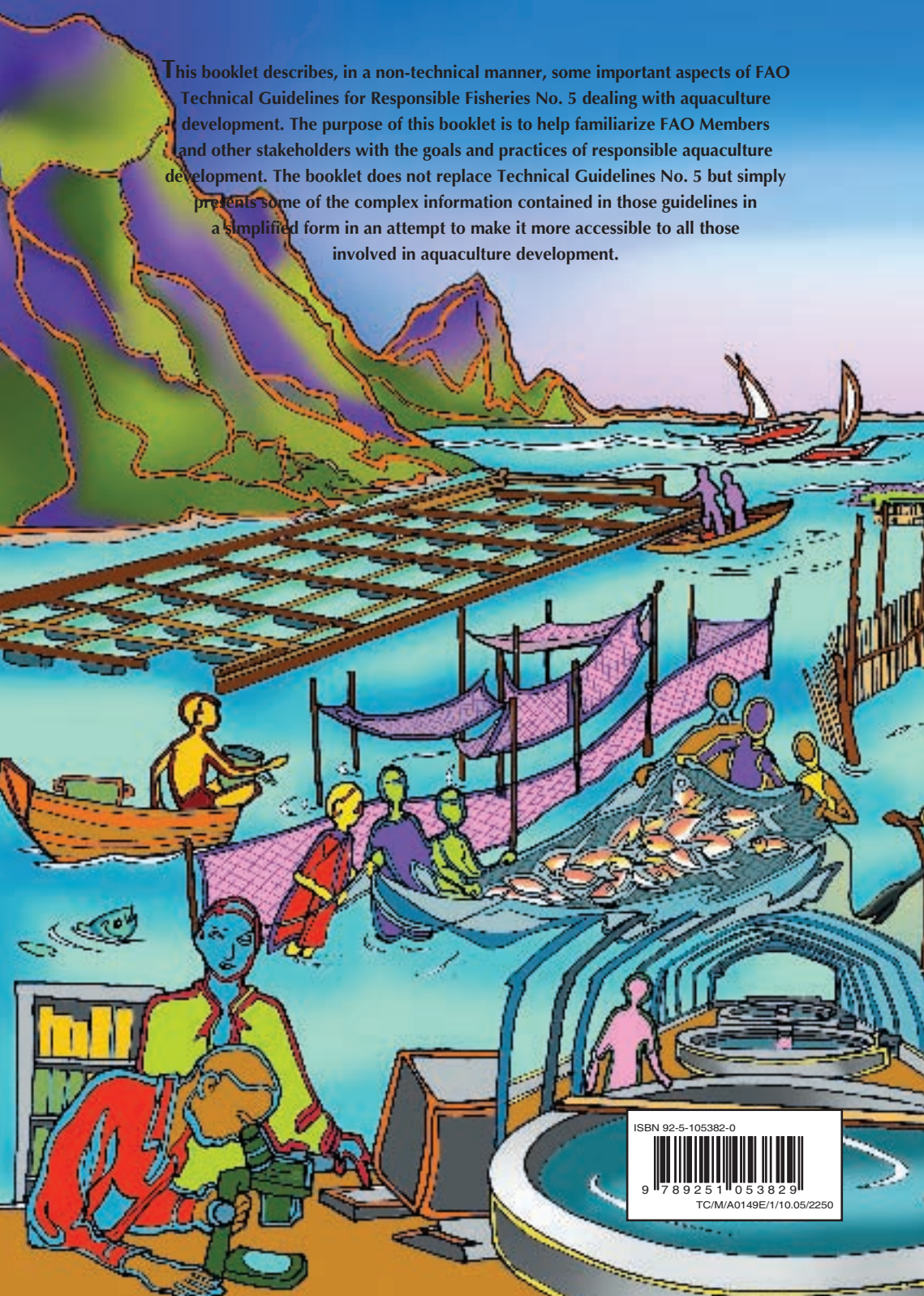

ISBN 92-5-105382-0



9 789251 053829

TC/M/A0149E/1/10.05/2250